

CITROËN

REPARATURHANDBUCH MAN 008583

FAHRZEUGE VISA

Austauschsatz Nr. 1 •

Nr. 2 ••

Nr. 3 •••

KAROSSERIE

Der Franzose



BENUTZUNG DES HANDBUCHS

Das Reparaturhandbuch für Visa-Fahrzeuge besteht aus zwei Bänden:

858-1 – Mechanik

858-3 – Karosserie

Aufbau von Band 1 und 3:

Die einzelnen Kapitel im Mechanik-Band sind in insgesamt 15 Gruppen unterteilt:
0 bis 15 – in Mechanik 1

- ① : Allgemeine Fahrzeugdaten
- ① : Motor
- ② : Gemischaufbereitung – Vergaser – Einspritzung
- ③ : Zündung
- ④ : Kupplung
- ⑤ : Getriebe – Gelenkwellen
- ⑥ : Hydraulik
- ⑦ : Vorderachse
- ⑧ : Hinterachse
- ⑨ : Federung – Radaufhängung – Räder – Reifen
- ⑩ : Lenkung
- ⑪ : Bremsen
- ⑫ : Elektrik und Radio
- ⑬ : Heizung und Belüftung
- ⑮ : Karosserie (Innen- und Außenausstattung)

Band 3 enthält die wesentlichen Arbeitsvorgänge zur Karosserieinstandsetzung.

- ① : Allgemeine Fahrzeugdaten
- ⑭ : Karosseriearbeiten
- ⑮ : Innen- und Außenausstattung

Jeder Band ist in einem Ringbuch eingeklebt. Dadurch kann das Handbuch leicht auf dem neuesten Stand gehalten und der in der Werkstatt durchzuführende Arbeitsvorgang schnell ausgeheftet werden.

Numerierung der Arbeitsvorgänge:

Die Numerierung der Arbeitsvorgänge wurde eingehend untersucht, um eine maximale Arbeitsqualität bei minimalem Zeitaufwand zu gewährleisten.

Die Kapitelnummern setzen sich wie folgt zusammen:

- a) **Kennbuchstabe des Fahrzeugs:** VD.Di
- b) **dreistellige Zahl:**
diese Zahl gibt die Baugruppe bzw. das Bauteil an
- c) **Reparatur-Kennziffer:**
diese Kennziffer gibt die Art der Reparatur an:
die Zahlen 0 0 0 bedeuten: allgemeine technische Daten
die Zahlen 0 0 bedeuten: technische Daten der Baugruppen
die Zahl 0 bedeutet: Kontrolle und Einstellung
die Zahlen 1, 4, 7 bedeuten: Aus- und Einbau
die Zahlen 2, 5, 8 bedeuten: Zerlegen und Zusammenbau
die Zahlen 3, 6, 9 bedeuten: Instandsetzung

Die Arbeitsvorgänge werden auf zwei Arten dargestellt:

1. durch Bilder, Zeichnungen und Texte,
2. durch Bilder, Zeichnungen und Symbole.

Erläuterung zu den Kapiteln

Die Kapitel „Technische Daten“ und „Aus- und Einbau“ bestehen aus Bild- und Textseiten.

Bei den Kapiteln „Instandsetzung“ und „Karosseriearbeiten“ werden die einzelnen Reparaturvorgänge mit Hilfe von Bildseiten und Symbolen veranschaulicht.

Eine Übersicht über sämtliche verwendeten Symbole ist in Form eines Kunststoffregisters am Anfang jeden Reparaturhandbuchs eingheftet.

Werkzeug

Das in dem Reparaturhandbuch „Mechanik 1“ verwendete Spezialwerkzeug ist nach jedem Inhaltsverzeichnis der einzelnen Baugruppen aufgeführt.

Im Karosseriehandbuch ist das benötigte Spezialwerkzeug entsprechend der Verwendung im Laufe der jeweiligen Reparaturarbeiten angegeben.

- Das Spezialwerkzeug kann an Hand der Referenznummer und der im Werkzeugkatalog befindlichen ET-Nr. vom Ersatzteilwesen bezogen werden.
- Das Werkzeug mit der Bezeichnung MR muß selbst hergestellt werden.

Austauschsätze

Die Reparaturhandbuchnummer (858-1 bzw. 858-3) ist unten rechts auf jeder rechten Seite angegeben.

Die im Kopf der Seiten angegebenen Zahlen von ① bis ⑮ geben an, in welcher Baugruppe die Austauschseiten einzuheften sind.

Austauschseiten sind wie folgt durch Punkte gekennzeichnet (Beispiel):

- 858-1 = Austauschsatz 1 zu 858-1
- 858-1 = Austauschsatz 2 zu 858-1

Anziehdrehmomente

Anziehdrehmomente sind in daNm (deka-Newton-Meter), der gesetzlich vorgeschriebenen Maßeinheit für Drehmomente, angegeben.

Aufgerundet entsprechen diese Werte ungefähr der alten Maßeinheit kpm (Kilopondmeter); in der Praxis demnach: 1 daNm = 1 kpm.

| Arbeitsvorgang Nr. | Bezeichnung |
|------------------------|---|
| VD.Di 000 | Allgemeine Fahrzeugdaten – Typenschilder – Punkte zum Heben und Abschleppen |
| VD.Di 03 Karosserie | Empfohlene Produkte |

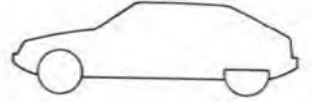

Der Franzose

| CITROËN | 0 | Empfohlene Dicht-, Klebe- und Korrosionsschutzmittel | VD.Di 03 Karosserie | 1 |
|---|--|--|--|---|
| DICHTMITTEL | | | | |
| Anwendung/Eigenschaften | Symbol | Markierung | ET-Nummer | |
| Dichtmittel (Kartusche) für Stahlblechverbindungen (lufttrocknend) |  | A 1 | — | |
| Dichtmittel (Kartusche) für Schweißverbindungen (schweißbar, wird vor dem Schweißen aufgetragen, nicht trocknend) | | A 2 | — | |
| Klebedichtmittel auf Polyurethanbasis | | A 3 | ZC 9 867 511 U ZC 9 867 447 U KN 1140 KN 1140 A | |
| Dichtungsband mit rundem Querschnitt |  | Ø = | KN 1187 | |
| Dichtungsband mit viereckigem Querschnitt |  | z. B.: 2 × 18 (Maße) | — | |
| KLEBEMITTEL | | | | |
| Anwendung/Eigenschaften | Symbol | Markierung | ET-Nummer | |
| Glas/Metallkleber für Innenspiegel etc. |  | B 1 | ZC 9 856 689 U | |
| Neoprenkleber für Verkleidungen etc. | | B 2 | KN 1188 | |
| Metallkleber für Türaußenbleche | | B 3 | ZC 9 867 263 U | |
| EPDM-Kleber für Stoßfänger | | B 4 | — | |
| Plastikkleber | | B 5 | ZC 9 865 105 U | |
| KORROSIONSSCHUTZMITTEL | | | | |
| Anwendung/Eigenschaften | Symbol | Markierung | ET-Nummer | |
| Stromleitendes Karosserieschutzmittel (vor dem Schweißen auftragen) |  | — | — | |
| Unterbodenschutzmittel |  | C 1 | — | |
| Steinschlagschutzmittel |  | C 2 | ZC 9 867 264 U | |
| Hohlraumschutzmittel |  | — | KN 1529 | |
| Falzschutzmittel (Türen) |  | A 4 | ZC 9 867 264 U | |

SCHMIERMITTEL UND FETTE

| Anwendung/Eigenschaften | Symbol | Markierung | ET-Nummer |
|--|---|------------|-----------|
| Mehrzweck-Schmiermittel auf Molybdänbisulfid-Basis |  | G 5 | — |
| Mehrzweck-Schmierfett | | G 6 | KN 1631 |

Der Franzose

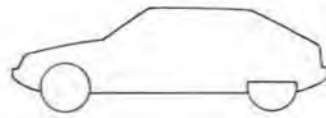

| | | | | | |
|---|---|---|--|--|---|
| <p>VISA 17 D VD-VT 23/03/84</p> <p>VISA 17 D ENTREPRISE VD-VT VERSION E 1/07/84</p> | <p>VISA 17 RD</p> <p>VD-VT 23/03/84 →</p> | <p>VISA 17 RD</p> <p>VD-VT/A 23/03/84 →</p> | <p>VISA 14 TRS</p> <p>VD-PE 01/07/84 →</p> | <p>VISA 14 TRS</p> <p>VD-PE/A 01/07/84</p> | <p>VISA GTi</p> <p>VD-PD 12/01/85 →</p> |
|---|---|---|--|--|---|

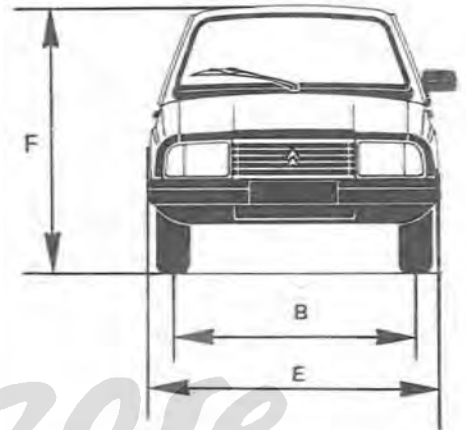
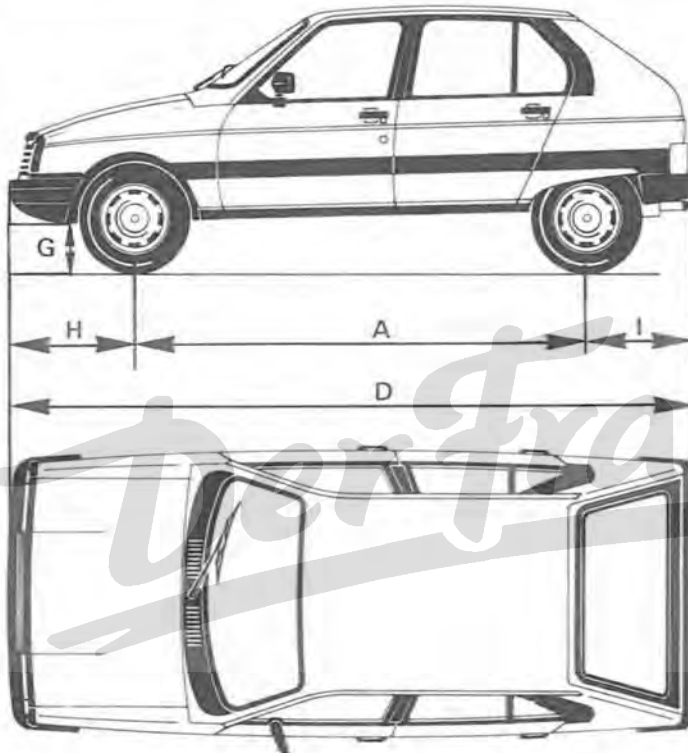

V80-74

| | VISA 17 | VISA 14 | VISA GTI |
|---|---------|---------|----------|
| A | 2,420 m | 2,426 m | 2,420 m |
| B | 1,350 m | 1,302 m | 1,392 m |
| C | 1,252 m | 1,251 m | 1,269 m |
| D | 3,690 m | 3,725 m | 3,725 m |
| E | 1,555 m | 1,526 m | 1,600 m |
| F | 1,410 m | 1,410 m | 1,370 m |
| G | 0,135 m | 0,135 m | 0,120 m |
| H | 0,675 m | 0,704 m | 0,710 m |
| I | 0,595 m | 0,595 m | 0,595 m |
| J | 10,06 m | 9,46 m | 10,06 m |
| K | 10,56 m | 9,89 m | 10,56 m |

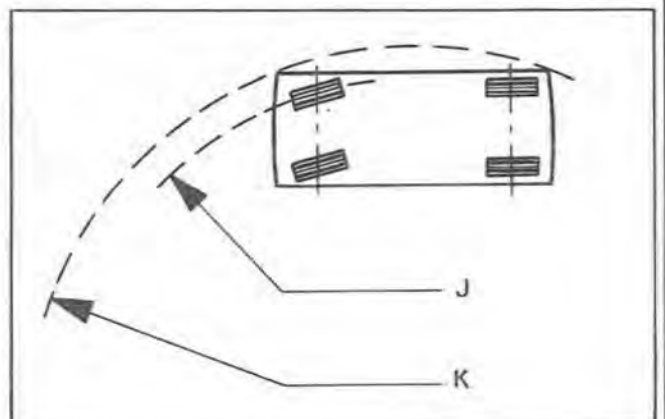

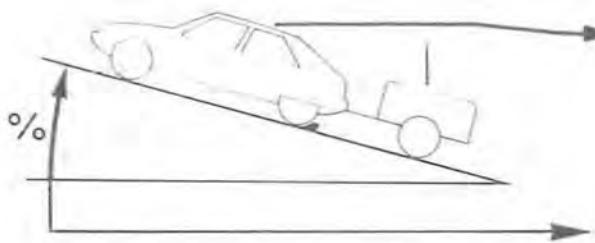
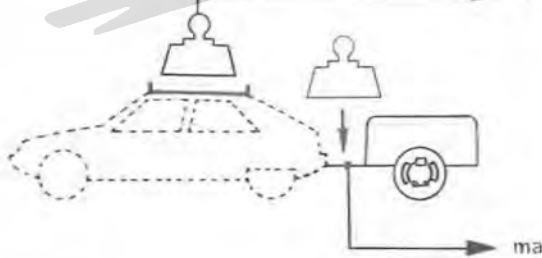
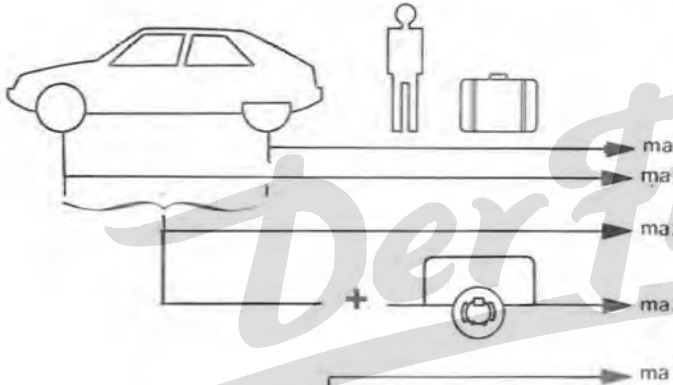
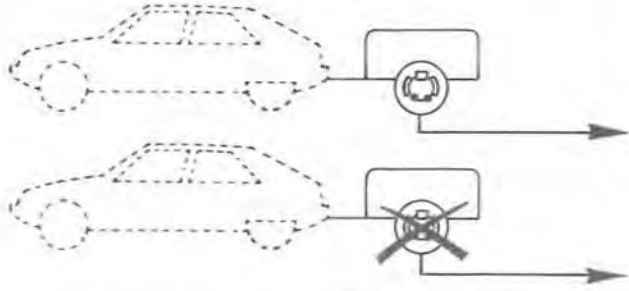
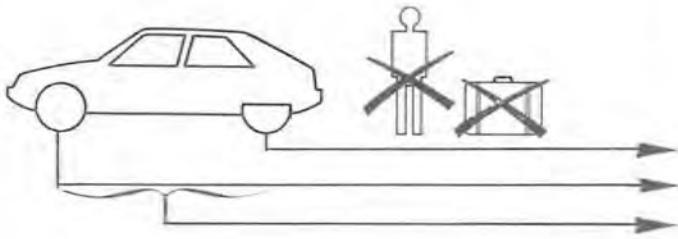
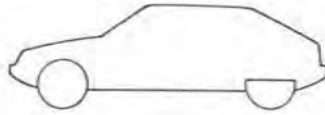

| | 17D | 17RD | 14 TRS | GTI |
|------|---------|--------|---------|---------|
| | 320 kg | | 320 kg | 345 kg |
| | 570 kg | | 510 kg | 525 kg |
| | 890 Kg | | 830 kg. | 870 kg |
| | | 750 kg | | |
| | 445 kg | | 415 kg | 435 kg |
| maxi | 630 kg | | 635 kg | |
| maxi | 680 kg | | 635 kg | |
| maxi | 1300 kg | | 1250 kg | 1210 kg |
| maxi | 2050 kg | | 1890 kg | 1960 kg |
| maxi | | 60 kg | | |
| maxi | | 45 kg | | |
| | 2050 kg | | 1890 kg | 1960 kg |
| | 16 % | | 11 % | |

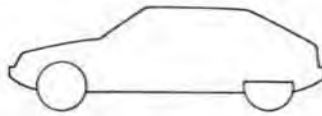

7

AUTOMOBILES CITROËN
VF7VDVT0000VT0001

3

VF7VDVT0000VT0001

2

161
A

1CT01
00081



| | |
|-------|--------|
| 161 A | 17 D |
| 150 D | 14 TRS |
| 180 A | GTi |

5

BM 00
000022



| | | |
|----------------|----|---------------|
| BM 60 | 44 | 17 D 17 RD |
| BL 60 | 44 | 17 RD |
| BT 81 BX 81 | 44 | 14 TRS |
| BT 87 | 44 | 14 TRS |
| BM 1 | 44 | GTi |

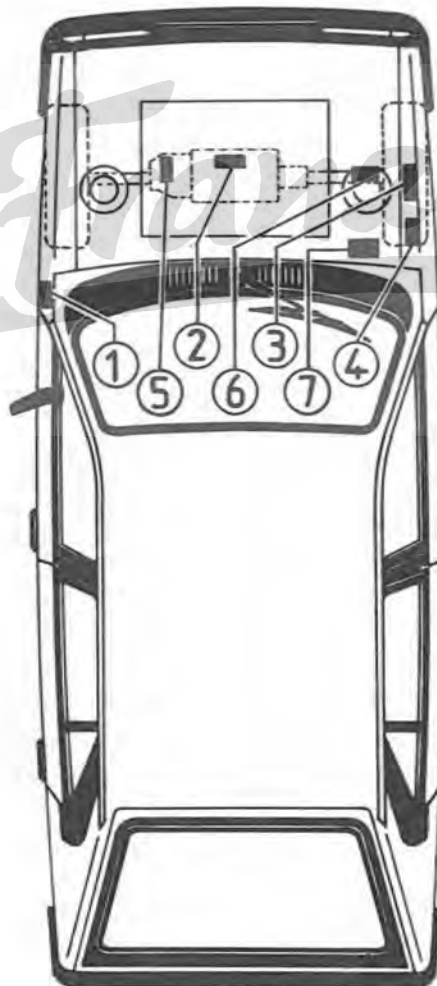

4

GVE-R



6



0001

1

AM
84

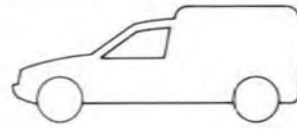
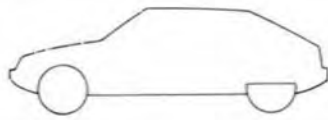

84 - 64

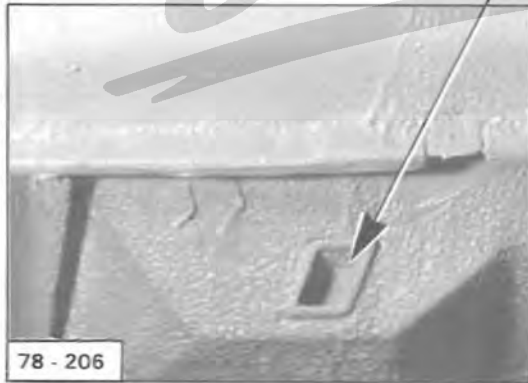
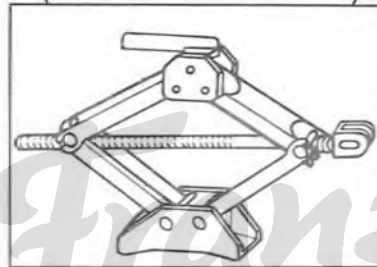

78 - 206



78 - 207

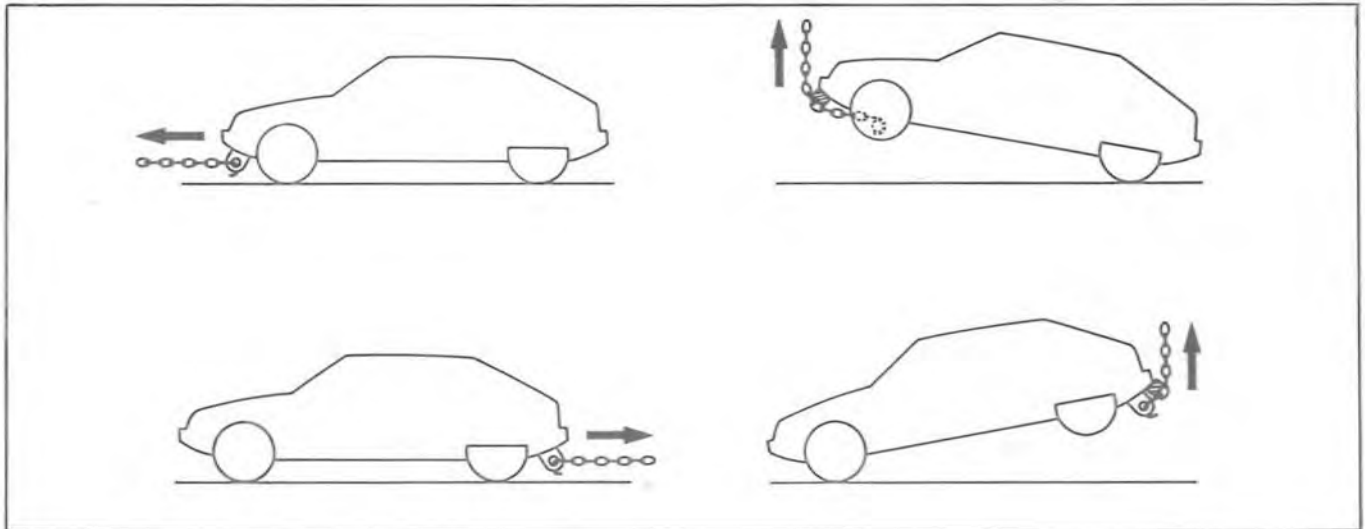

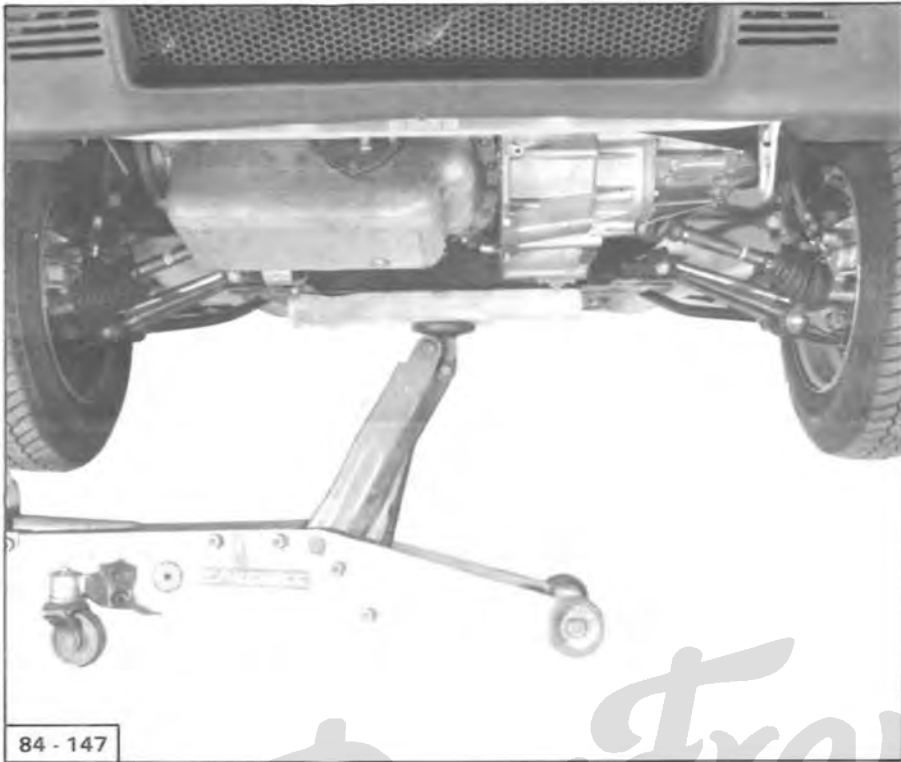
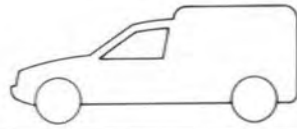
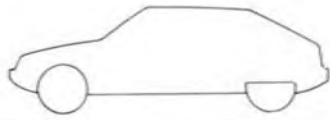

84 - 147



83 - 1326

Der Franzose



84 - 65



83 - 1325

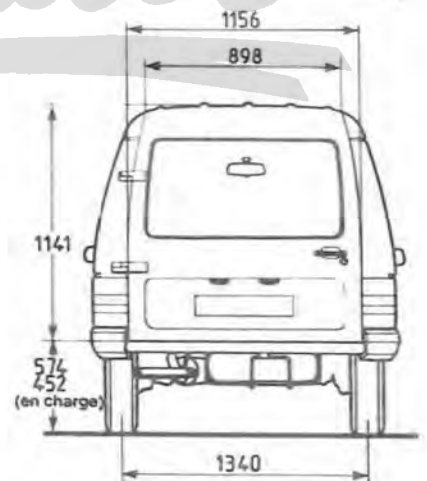
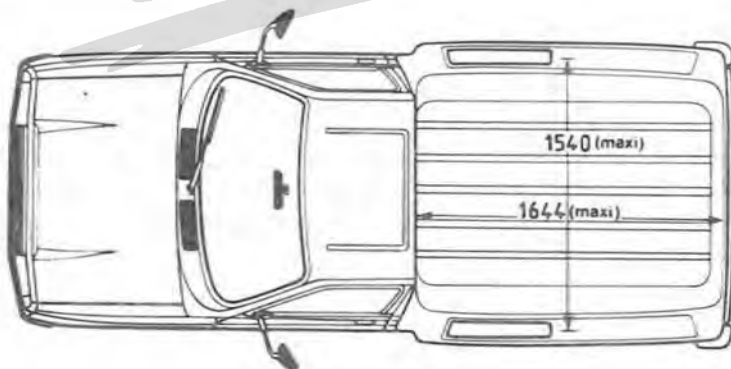
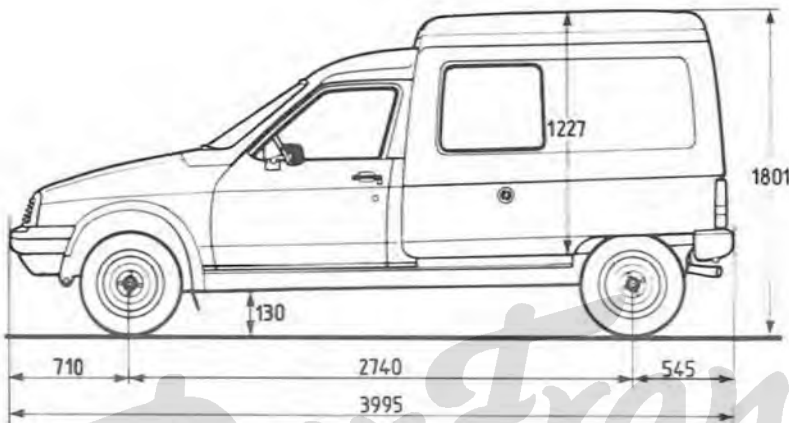
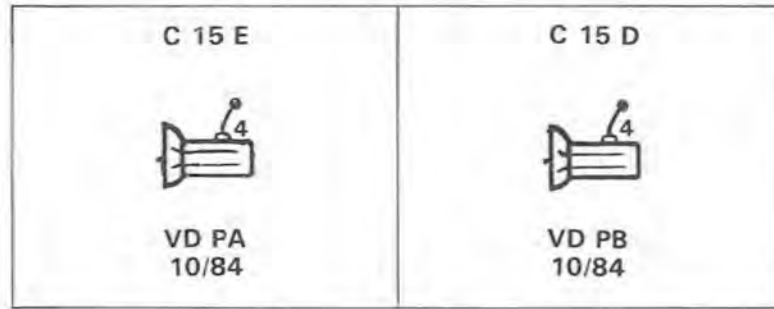
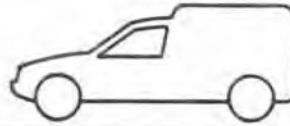

V80-105

| | C 15 E | C 15 D |
|---|---------|---------|
| A | 10 m | 11 m |
| B | 10,56 m | 11,54 m |

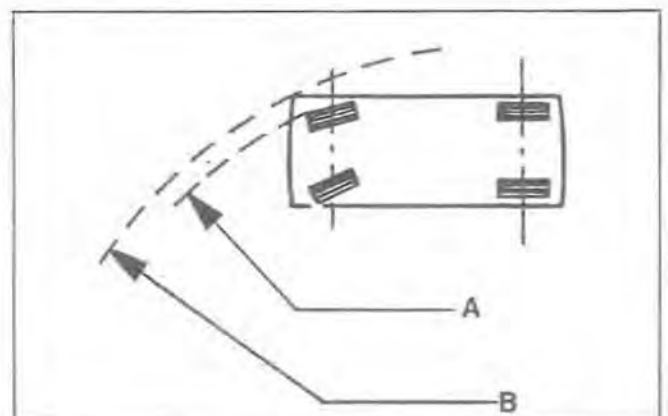

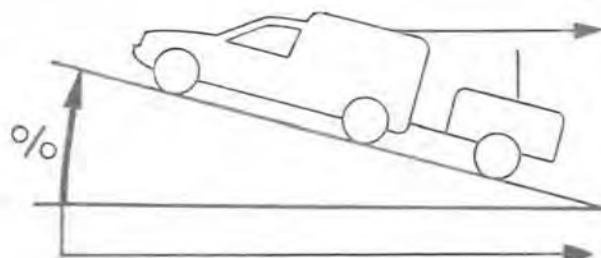
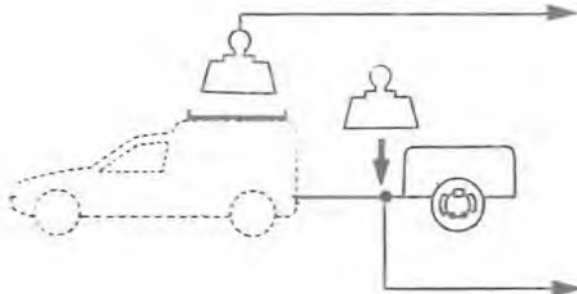
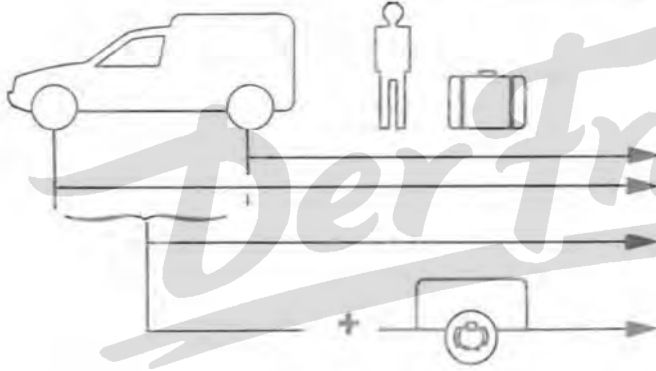
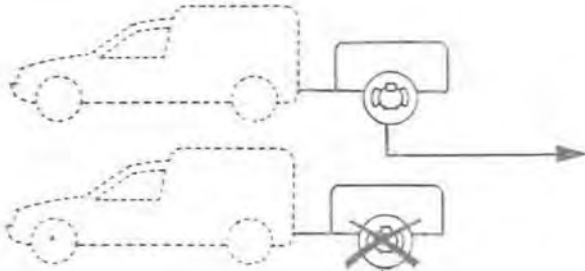
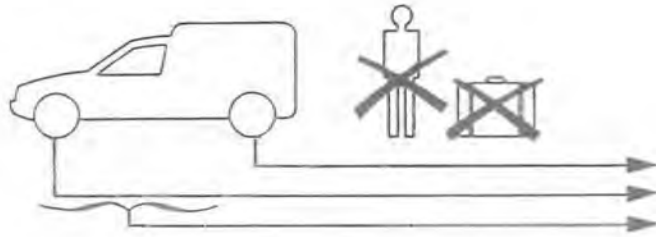
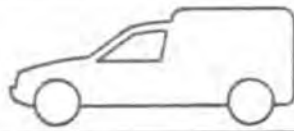

| | C 15 E | C 15 D |
|------|----------------------------|----------------------------|
| | 330 kg 520 kg 850 kg | 335 kg 590 kg 945 kg |
| | 800 kg | |
| | 425 kg | 475 kg |
| maxi | 800 kg | 830 kg |
| maxi | 680 kg | 740 kg |
| maxi | 1435 kg | 1530 kg |
| maxi | 1950 kg | 2150 kg |
| maxi | 80 Kg | |
| maxi | 1950 kg | 2150 kg |
| | 12 % | |
| | 2,672 m ³ | |



7

AUTOMOBILES CITROEN
VF7VDVT0000VT0001

2

161
A

1CT01
00081



| | |
|-------|--------|
| 109 K | C 15 E |
| 161 A | C 15 D |

3

VF7VDVT0000VT0001

5

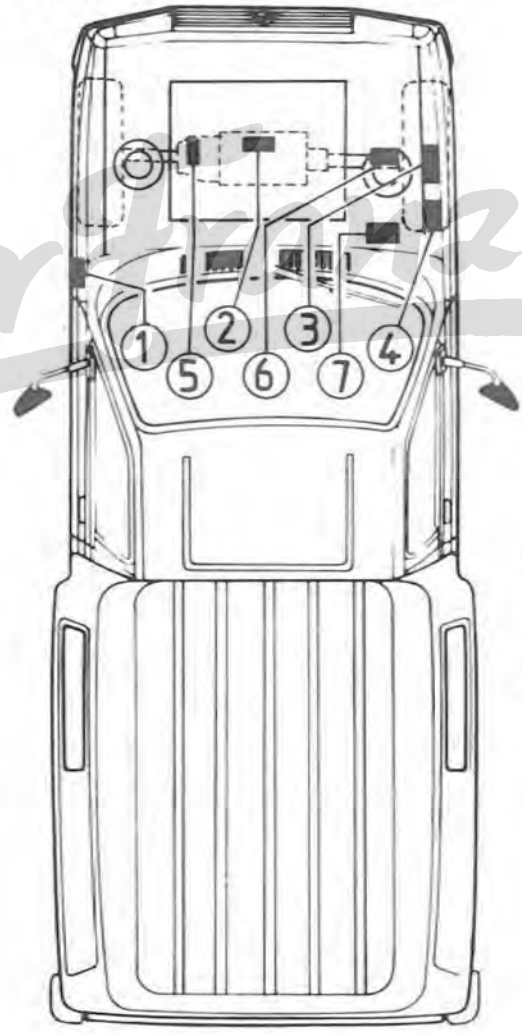

BM00
000022



| | | |
|-------|---|--------|
| BT 79 | 4 | C 15 E |
| BM 61 | 4 | C 15 D |

4

GVE-R



6

0001

1

AM
85

| Arbeitsvorgang Nr. | Bezeichnung |
|-----------------------|--|
| VD.Di 800-000 | Bauteile der selbsttragenden Karosserie Elektrolytisch verzinkte Teile |
| VD.Di 800-00 | Vorbereitung der Karosserie I. — Abdichtung mit Dichtmittel II. — Unterbodenschutz III. — Hohlraumversiegelung IV. — Steinschlagschutz |
| VD.Di 800-0 | Kontrollen auf der Richtbank Ausrüstung der Richtbank „Celette“ |
| VD.Di 800-1 | Kontrolle auf einer Richtbank „Celette“ |
| VD.Di 800-10 | Kontrolle einer Rohkarosserie auf einer Richtbank „Caroliner“ |
| VD.Di 800-11 | Kontrolle eines Fahrzeugs auf einer Richtbank „Caroliner“ |
| VD.Di 800-20 | Kontrolle einer Rohkarosserie auf einer Richtbank „Dataliner“ |
| VD.Di 800-21 | Kontrolle eines Fahrzeugs auf einer Richtbank „Dataliner“ |
| VD.Di 801-1 | Frontpartie Erneuern eines Scheinwerfertragblechs |
| VD.Di 801-4 | Erneuern der unteren Fronttraverse |
| VD.Di 801-7 | Vorderer Radkasten Erneuern eines Radkastenseitenteils |
| VD.Di 802-1 | Erneuern eines kompletten vorderen Radkastens (mit Längsausleger) |
| VD.Di 802-3 | Erneuern eines vorderen Längsauslegers |
| VD.Di 802-5 | Erneuern eines vorderen Längsausleger-Teilstücks |
| VD.Di 802-7 | Erneuern eines vorderen Radkastens |
| OUT 50-4077-T | Spezialwerkzeug Liste der in diesem Kapitel verwendeten Spezialwerkzeuge: Anreißschablone zur Erneuerung eines vorderen Längsausleger-Teilstücks |

Der Franzose

INSTANDSETZUNG EINER KAROSSERIE

I – Bauteile der selbsttragenden Karosserie

| Markierung | Bezeichnung | Arbeitsvorgang |
|------------|--|----------------|
| A | Untere Fronttraverse | VD.Di 801-4 |
| B | Vorderes Teil des Längsauslegers | VD.Di 802-5 |
| C | Scheinwerfertragblech | VD.Di 801-1 |
| D | Vorderer Radlaufkasten | VD.Di 802-1 |
| E | Vorderer Längsträger | VD.Di 802-3 |
| F | Vorderes Radkastenseitenteil | VD.Di 801-7 |
| G | Unteres Windschutzscheibenrahmenteil | |
| H | Seitenteil des Windschutzscheibenrahmens | |
| I | Hinterteil des Seitenrahmens | |
| J | Kofferraumboden | |
| K | B-Säule (mittlerer Seitenholm) | |
| L | Traverse unter den Rücksitzen | |
| M | A-Säule (vorderer Türholm) | |
| N | Füllblech des vorderen Seitenrahmens | |
| O | Dach | |
| P | Füllblech der B-Säule | |
| Q | Hinteres Dachtraverse | |
| R | Füllblech des hinteren Kotflügels | |
| S | Hinterer Radlaufkasten | |
| T | Heckabschlußblech | |
| U | Hinterer Kotflügel | |
| V | Traverse unter den Vordersitzen | |
| W | Türeinstiegsweller | |
| X | Seitenrahmen komplett | |
| Y | Vorderes Bodenblech | |
| Z | Spritzwand-Oberteil | |

} siehe
Reparatur-
handbuch
VD. 857-3

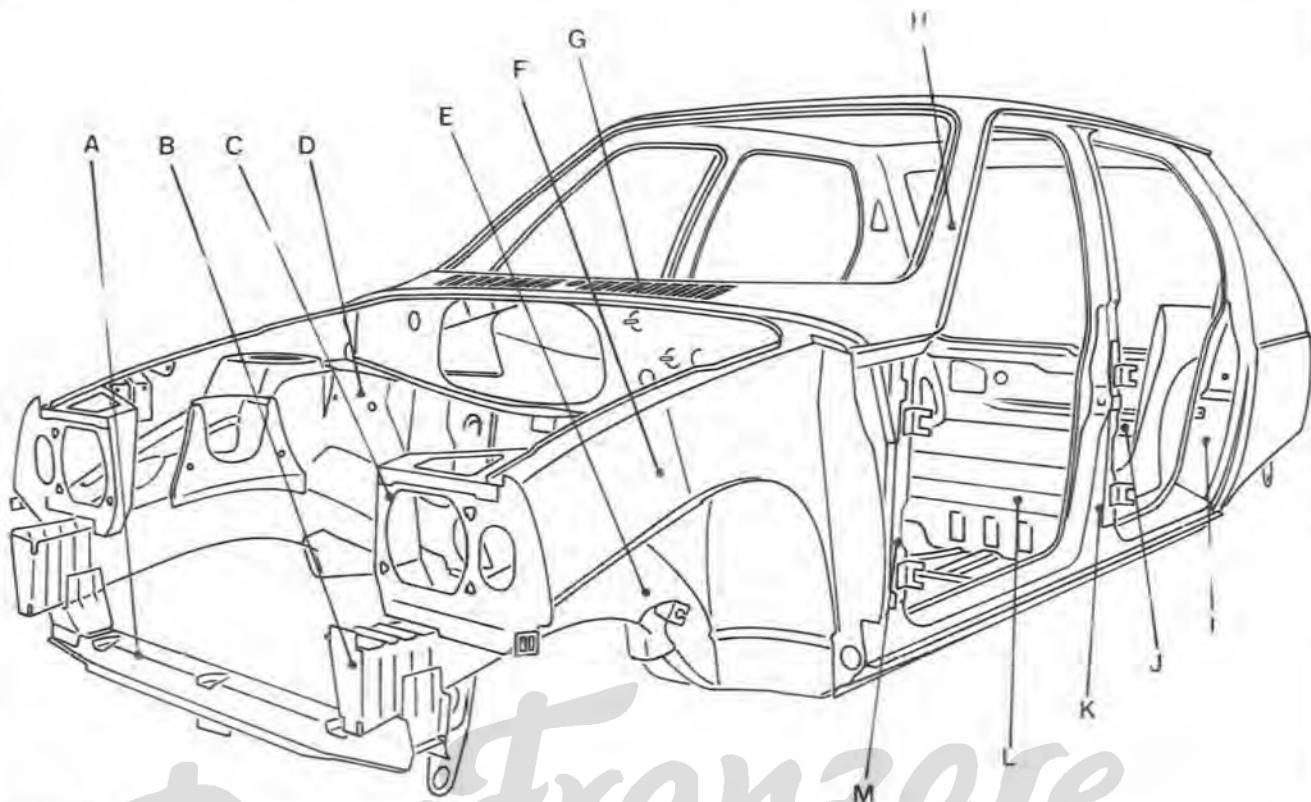

V. 80-66

Der Franzose

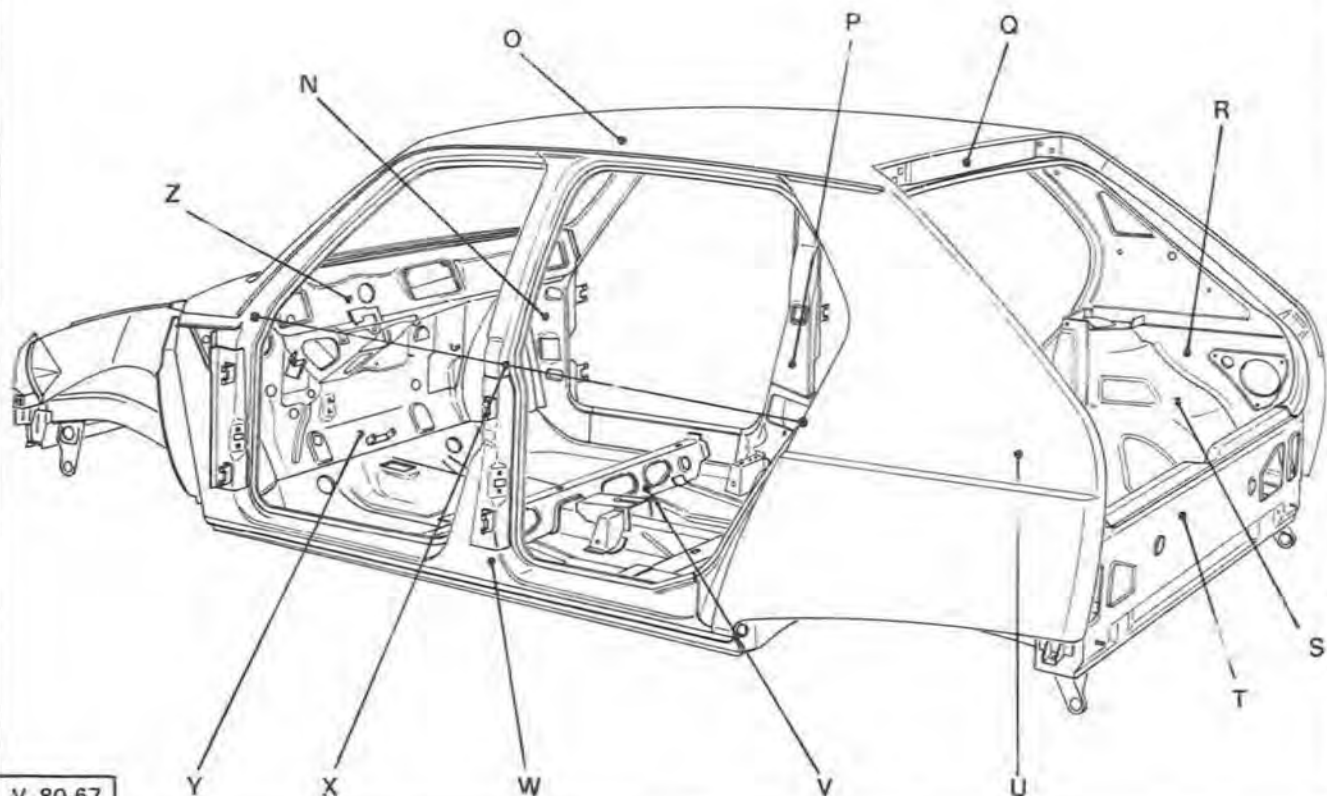

V. 80-67

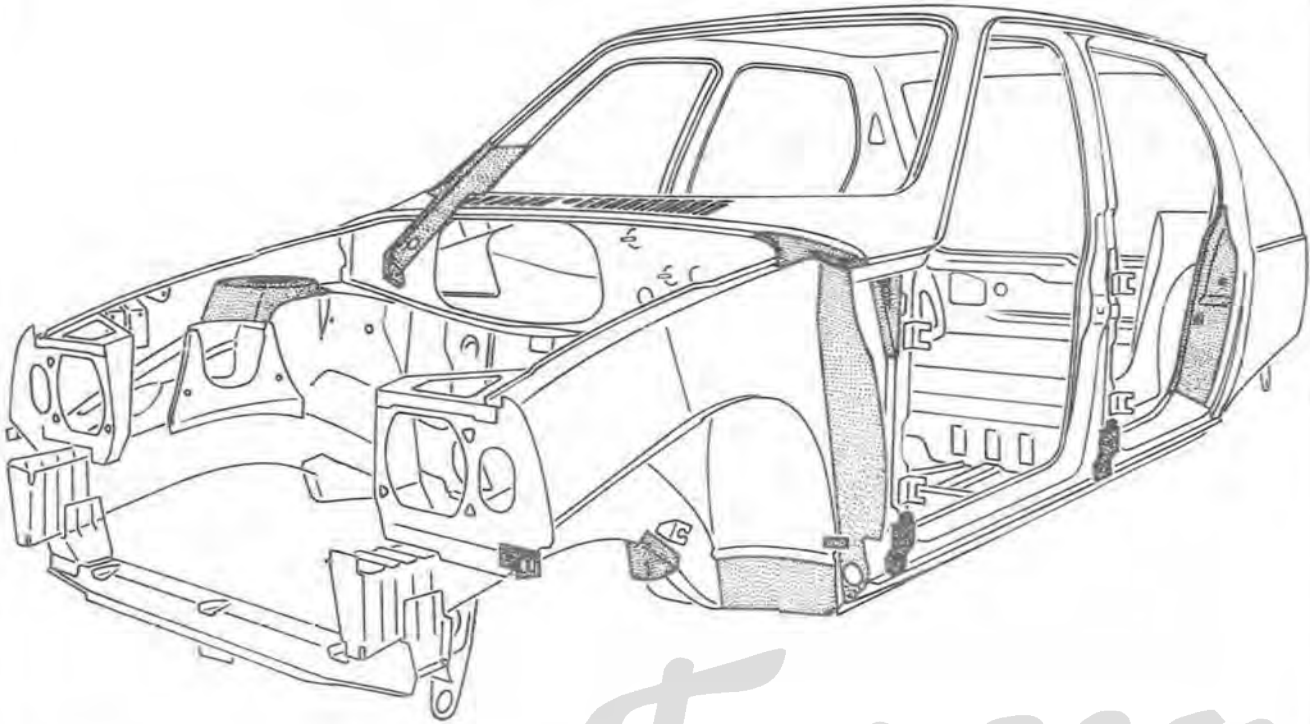

V. 80-98

Der Franzose

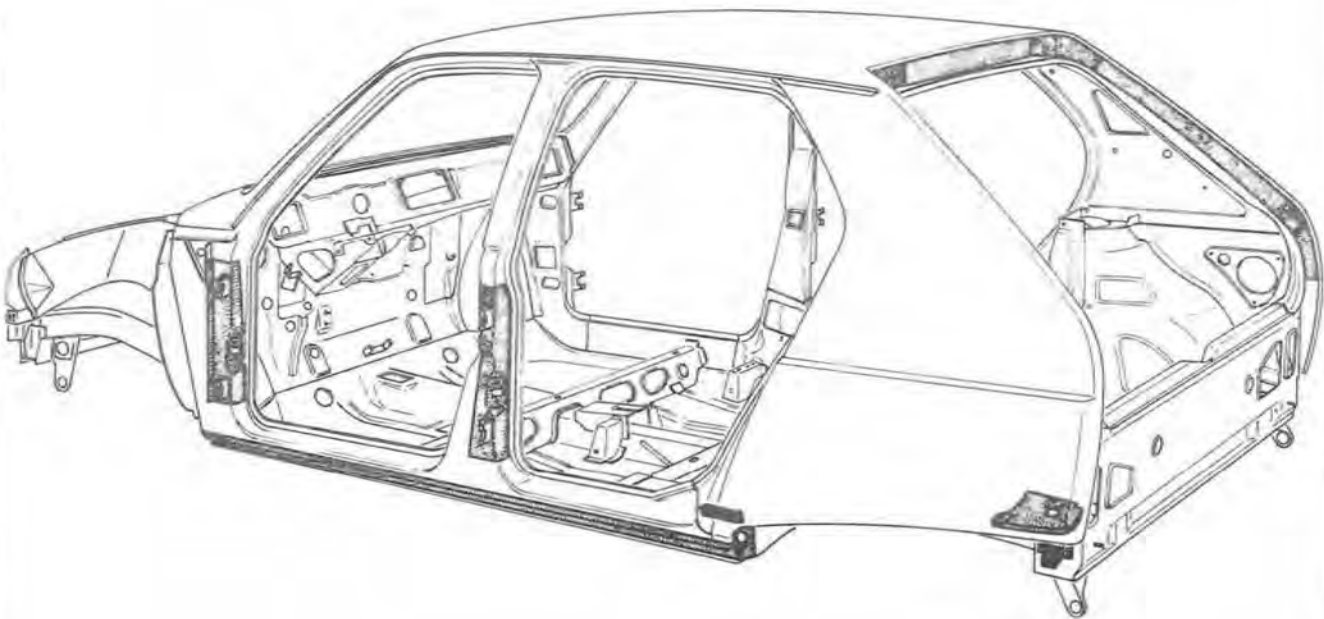

V. 80-99

Elektrolytisch verzinkte Blechteile

Die in der nebenstehenden Darstellung dunkel hervorgehobenen Teile sind elektrolytisch verzinkt, um die Karosserie vor Korrosion zu schützen.

Die Auswahl dieser Teile erfolgte nach Anfälligkeit der verschiedenen Bereiche und kann nach Bedarf verändert werden.

Die vom Ersatzteilwesen verkauften Teile werden der gleichen Behandlung unterzogen. Von außen ist dies jedoch nicht sichtbar, da diese Teile mit einer Kataphorese-Schicht überzogen sind.

Reparatur

Bei der Reparatur muß die Kataphorese-Schicht in den Schweißbereichen von beiden Seiten des Bleches entfernt werden. Dadurch wird auch der Zinküberzug beschädigt.

Um Korrosionsbildung nach der Reparatur (insbesondere an den Schweißstellen) zu verhindern, müssen bestimmte Vorsichtsmaßnahmen beachtet werden:

- Vermeiden, daß die Schweißstellen an den neuen Teilen abgeschliffen werden (durch die Schleifscheiben wird der Zinküberzug zerstört), sondern mit dem Schweißbrenner die Bereiche leicht erhitzen und mit der Stahlbürste abbürsten.
- Nach Austrennen der Teile das Schleifen auf die Stellen begrenzen, wo eine Schweißstelle war.

Schutzmaßnahme vor dem Schweißen

Zur Verhinderung von Korrosionsbildung ist auf der Innenseite der zu schweißenden Bleche (ob mit oder ohne elektrolytische Verzinkung) ein leitender Grundanstrich anzubringen.

Anmerkung:

„Leitende“ Grundanstriche sind aufgetragene Zinkfarben, welche den Stromfluß ermöglichen, ohne jedoch den Schweißvorgang zu berücksichtigen. Es ist jedoch erforderlich, die Stromstärke zu erhöhen.

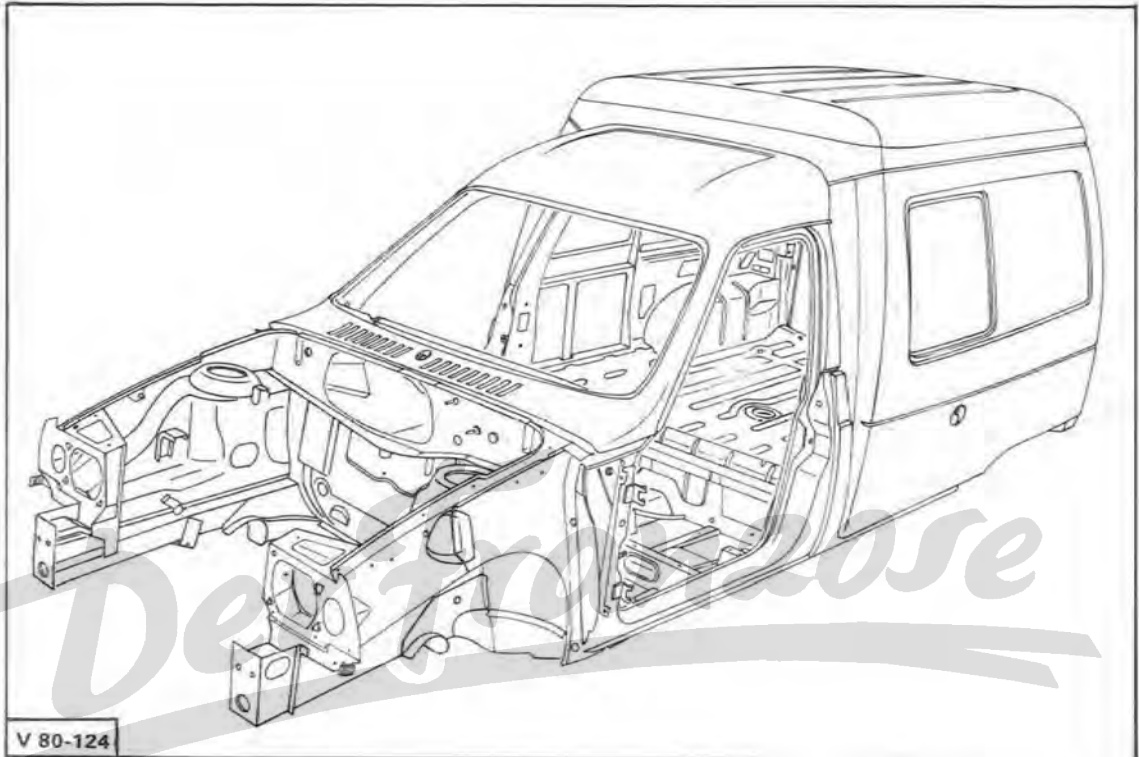

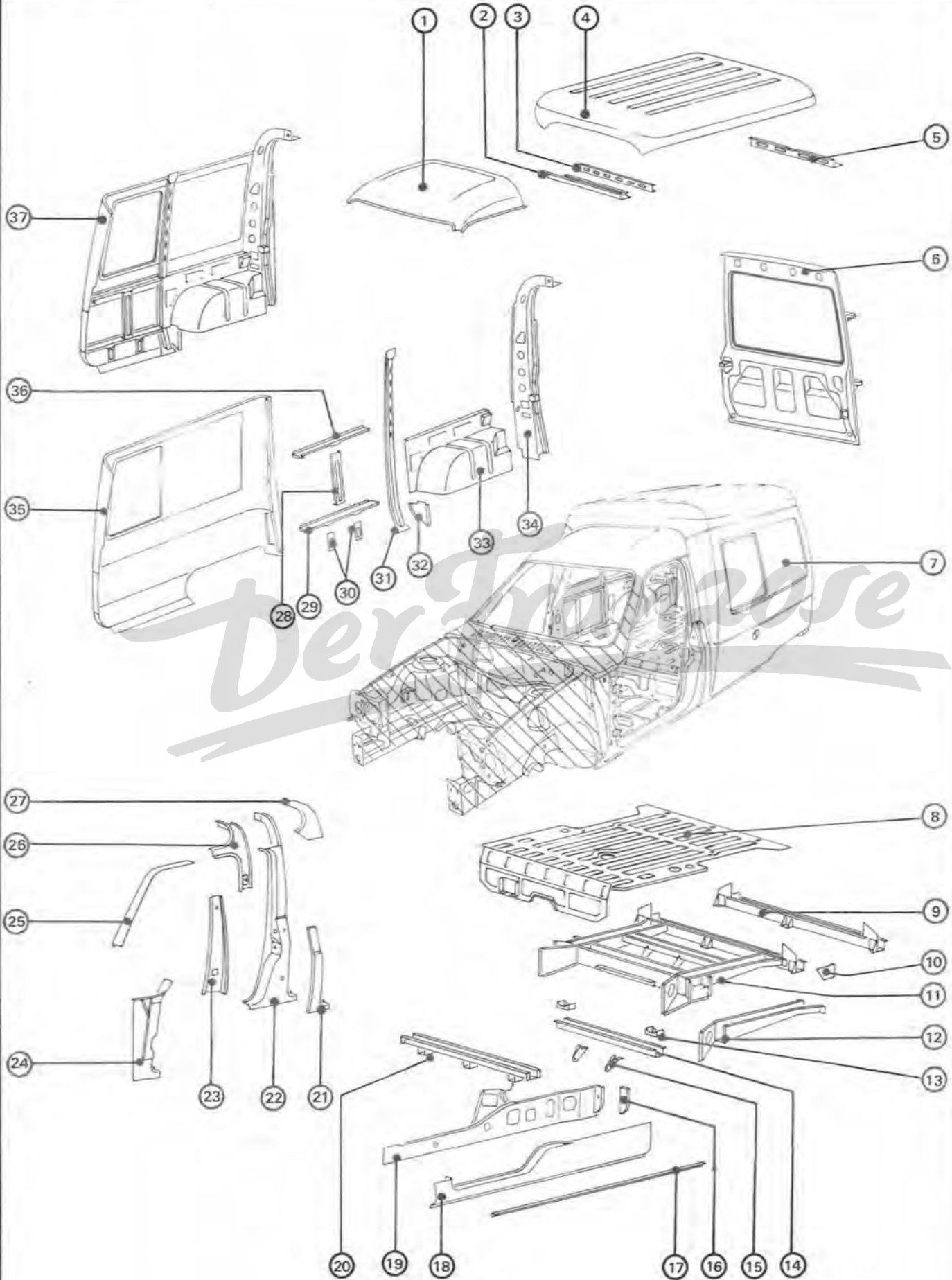

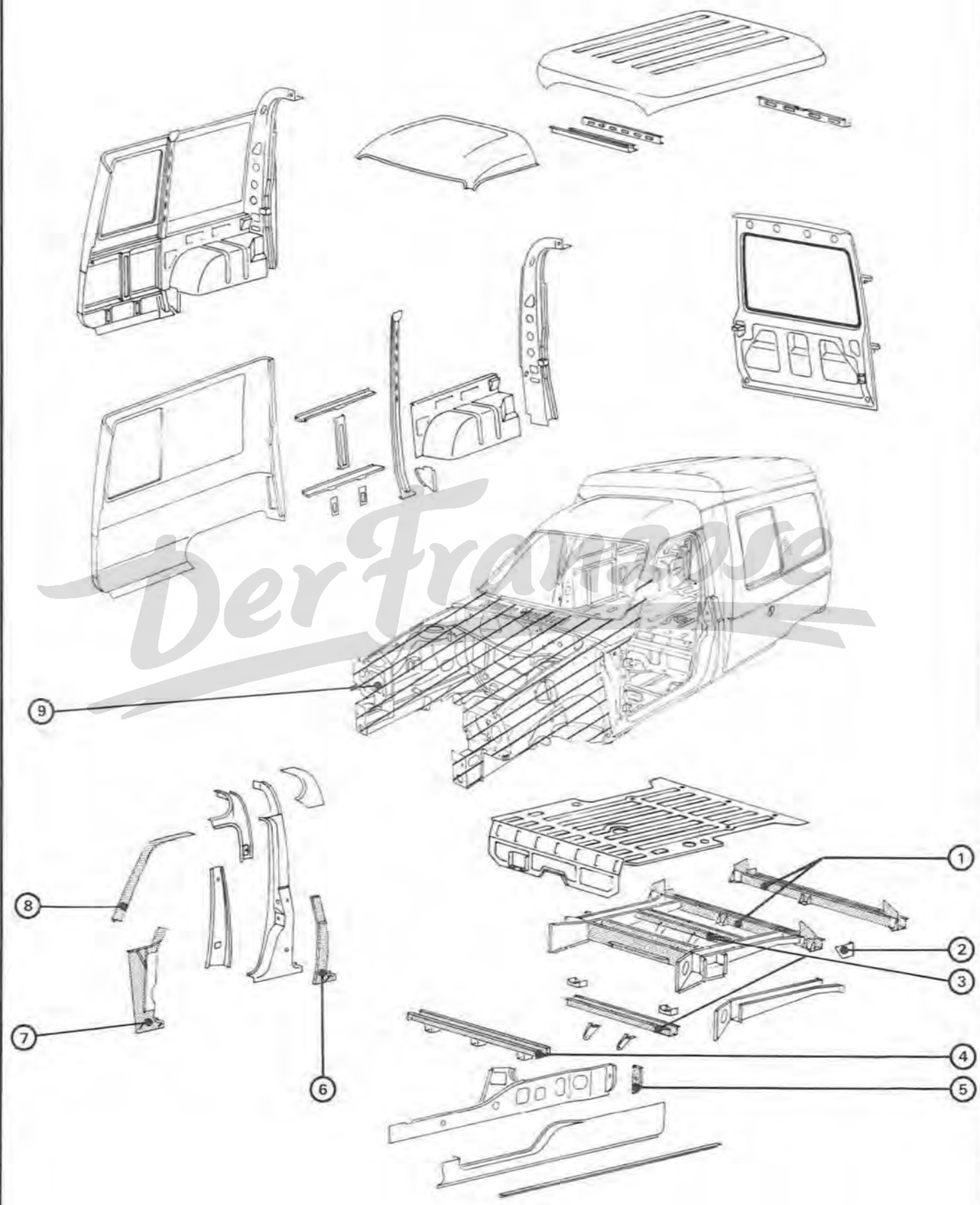

V 80-126 - V 80-124

*

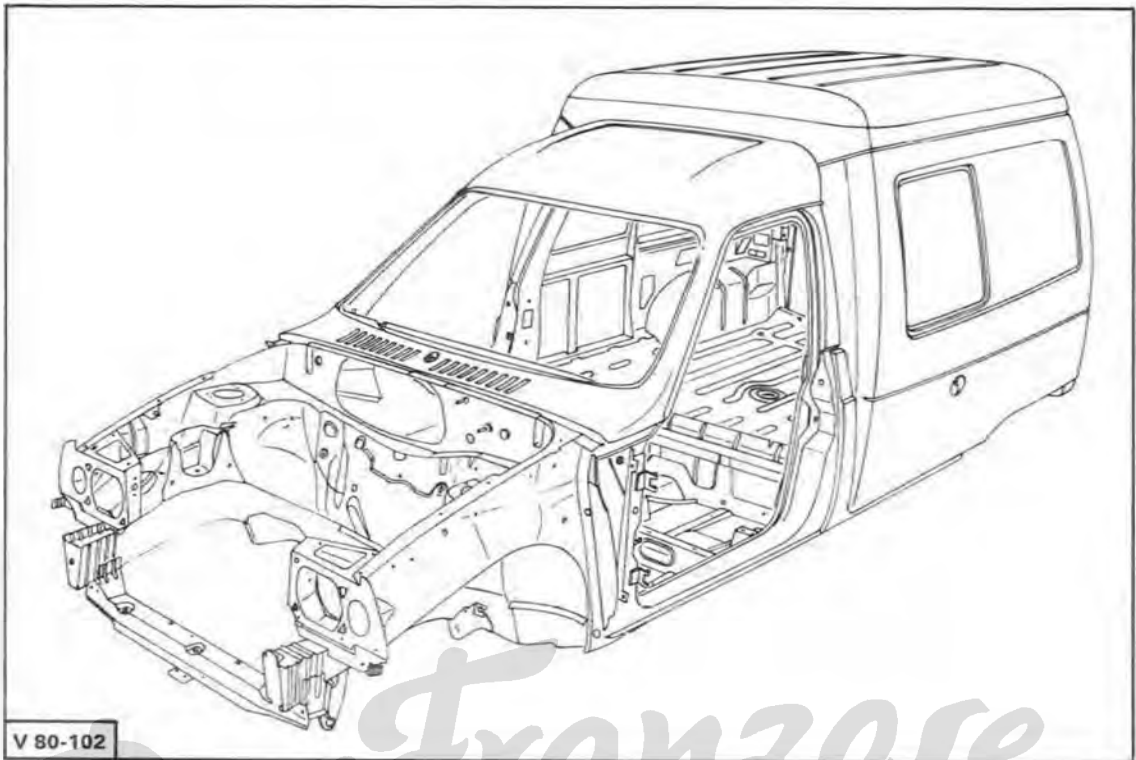

Der Franzose

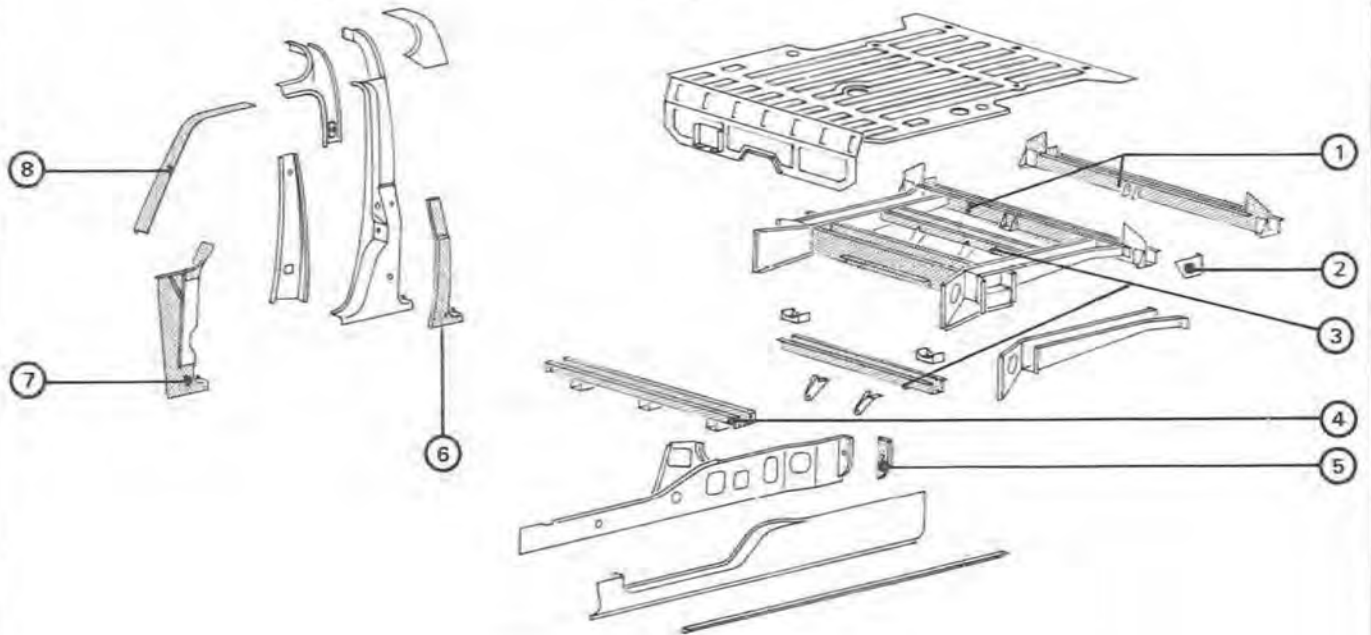
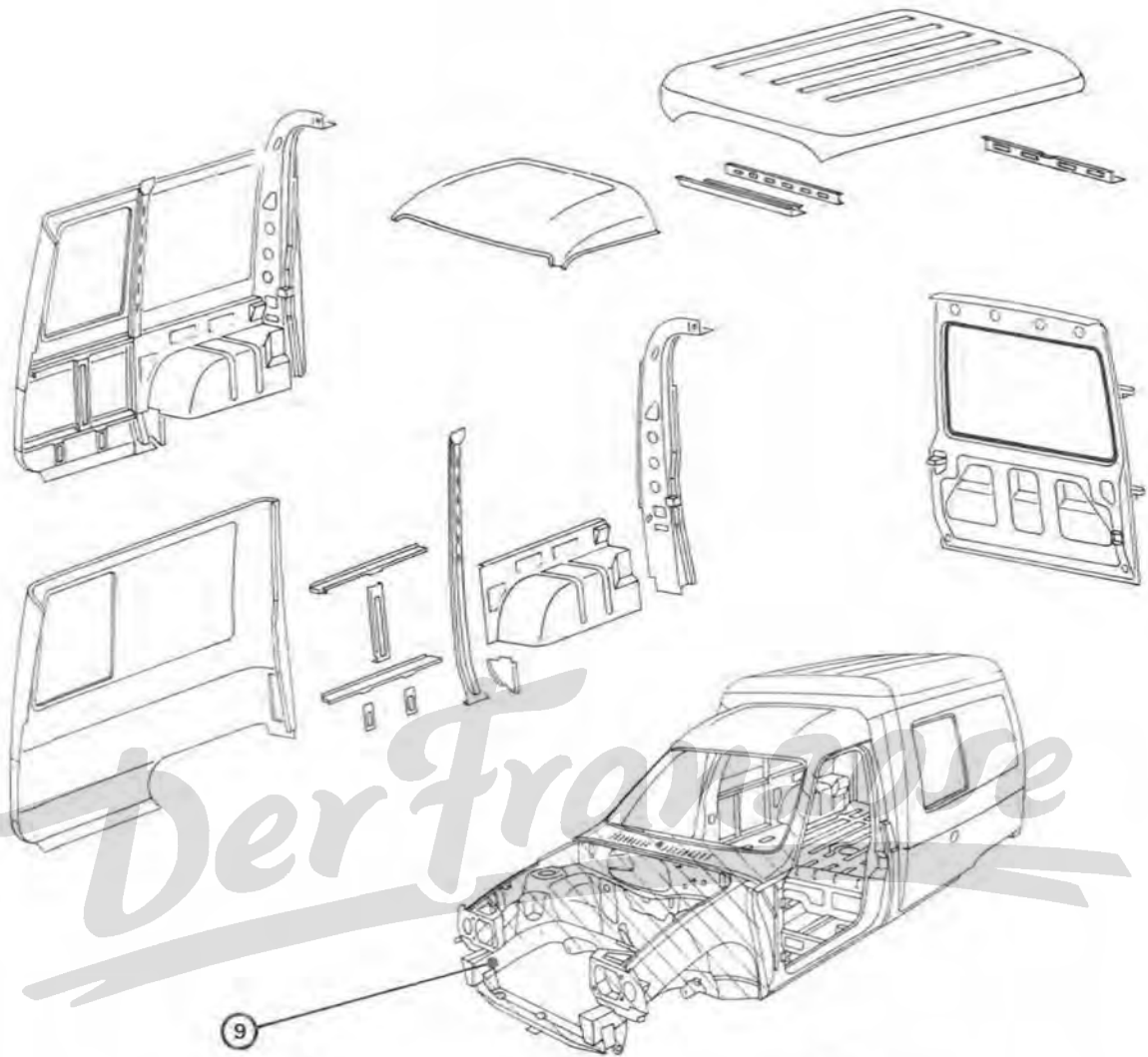

V 80-125 V 80-102

*

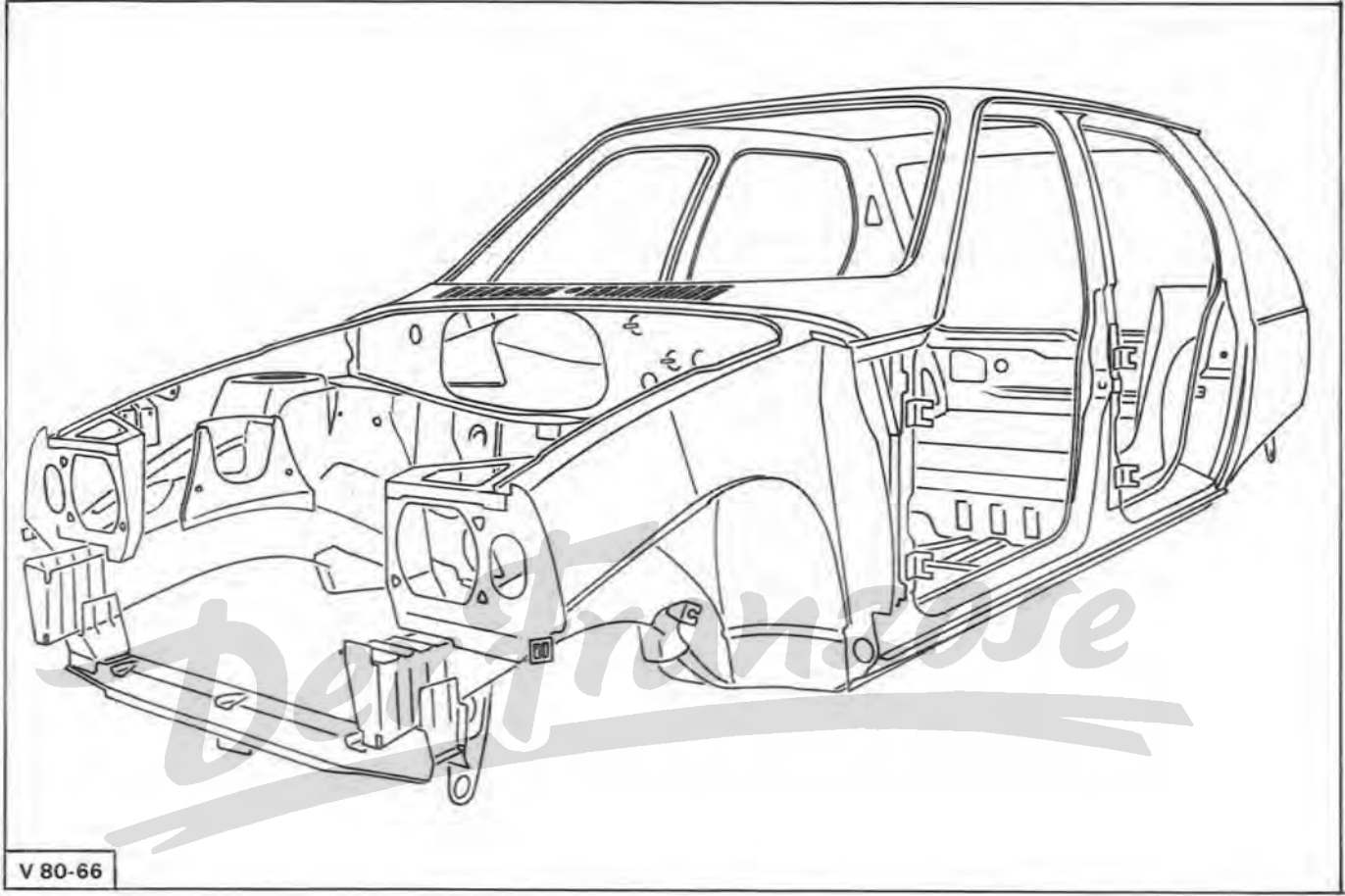
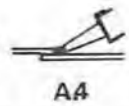
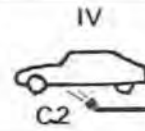
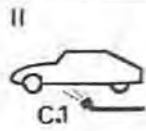

V 80-66

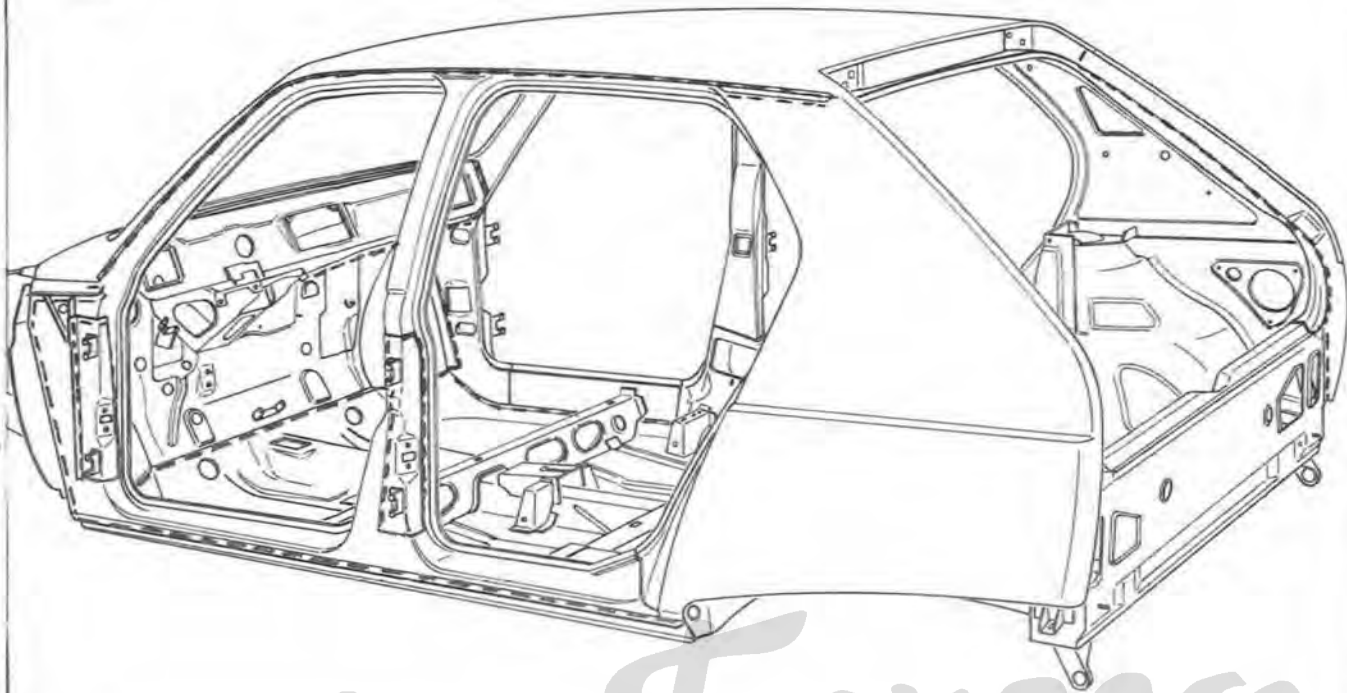
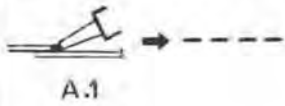

V 80-67

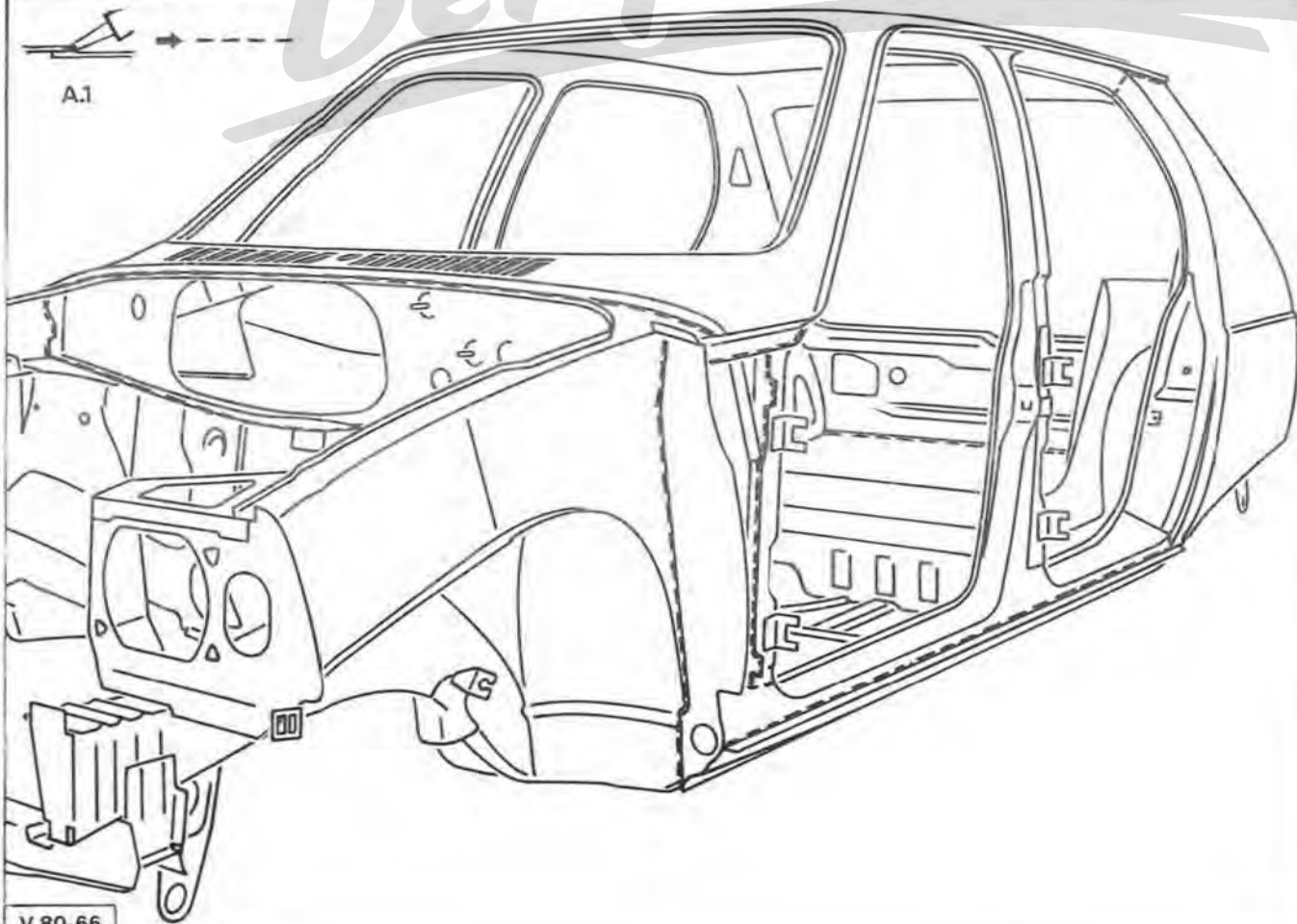
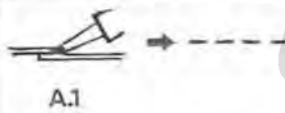

V 80-66

Der Franzose

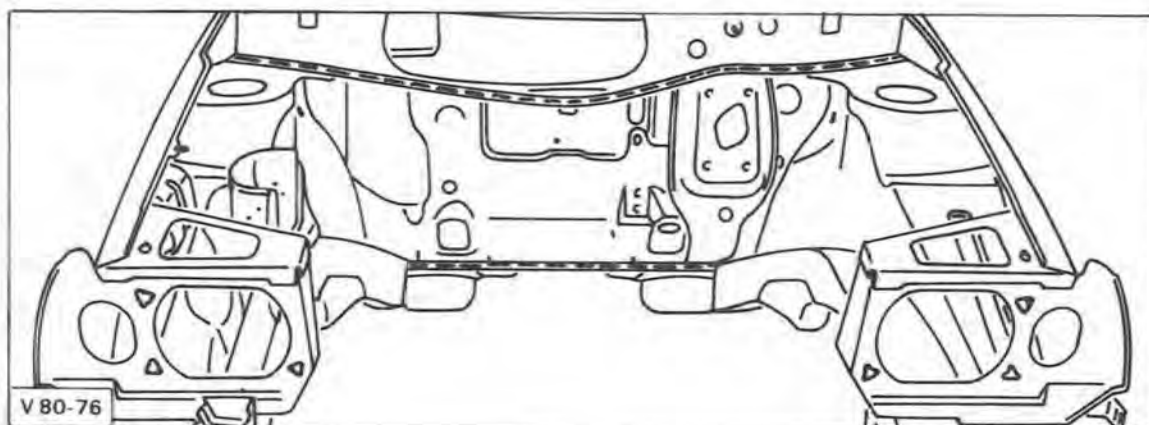
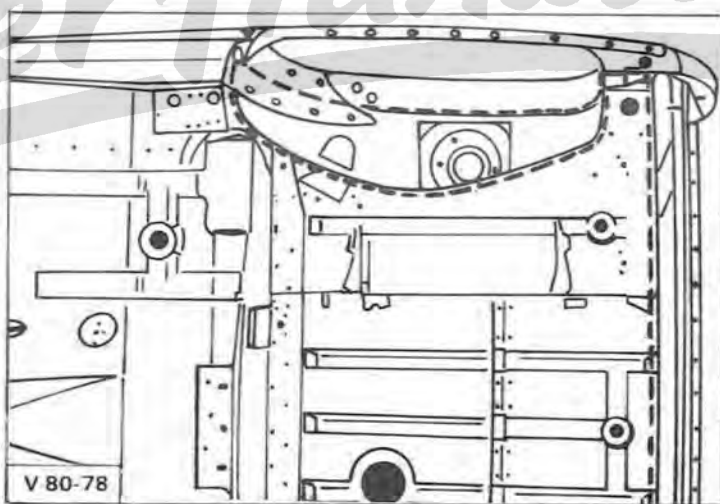
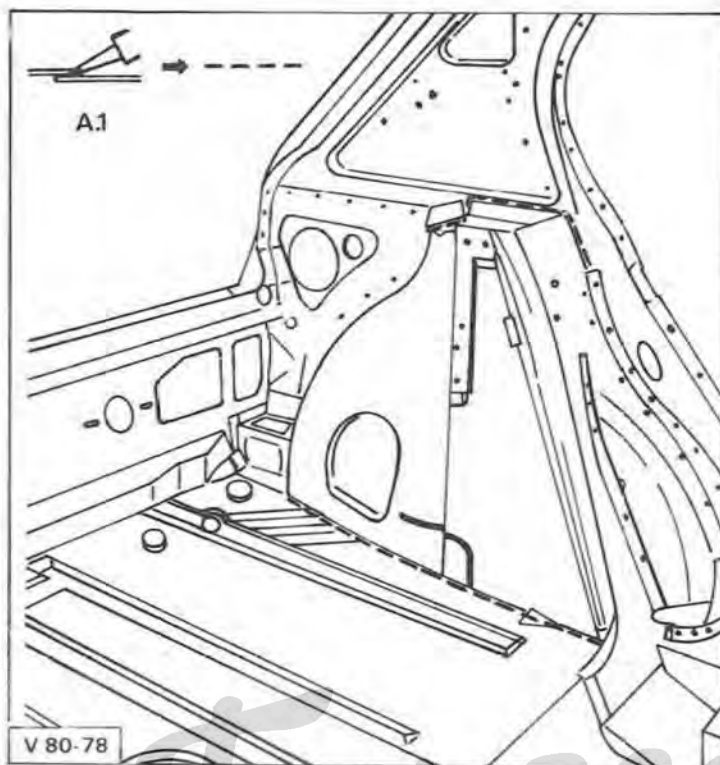

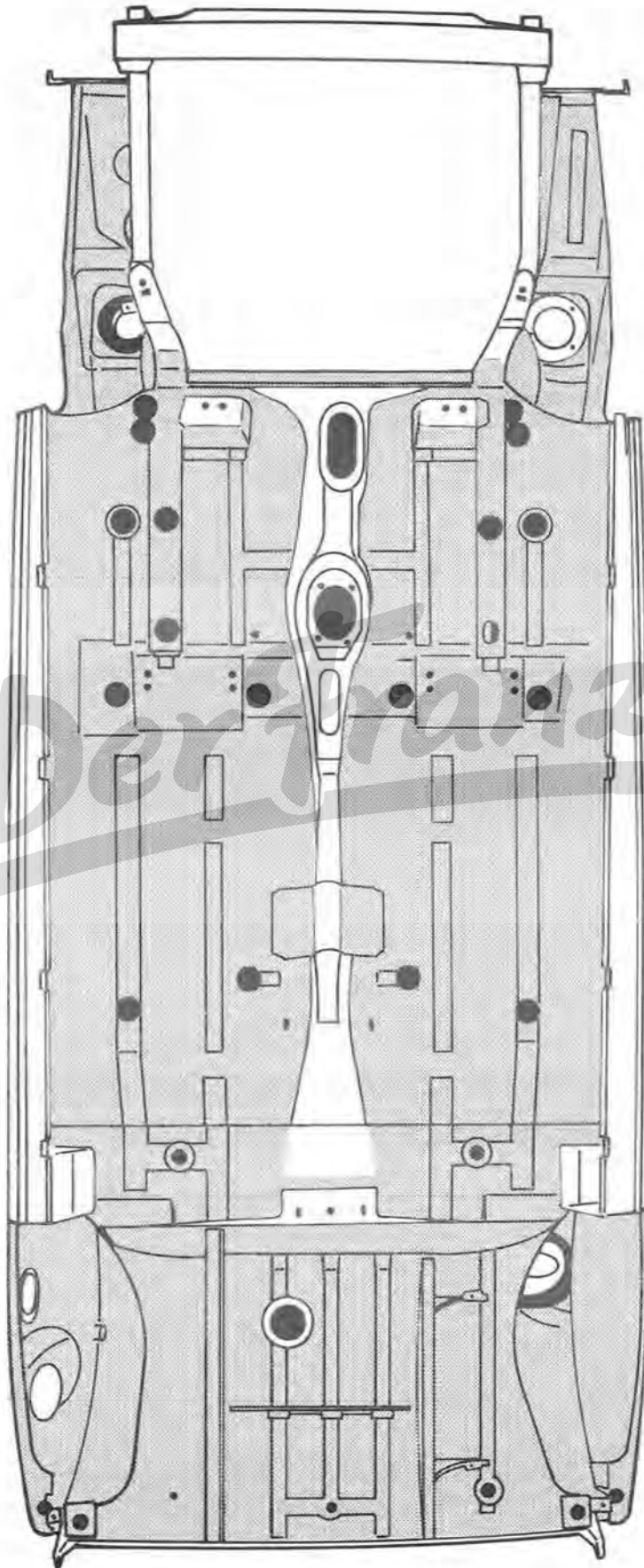
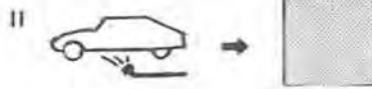

Derranzose

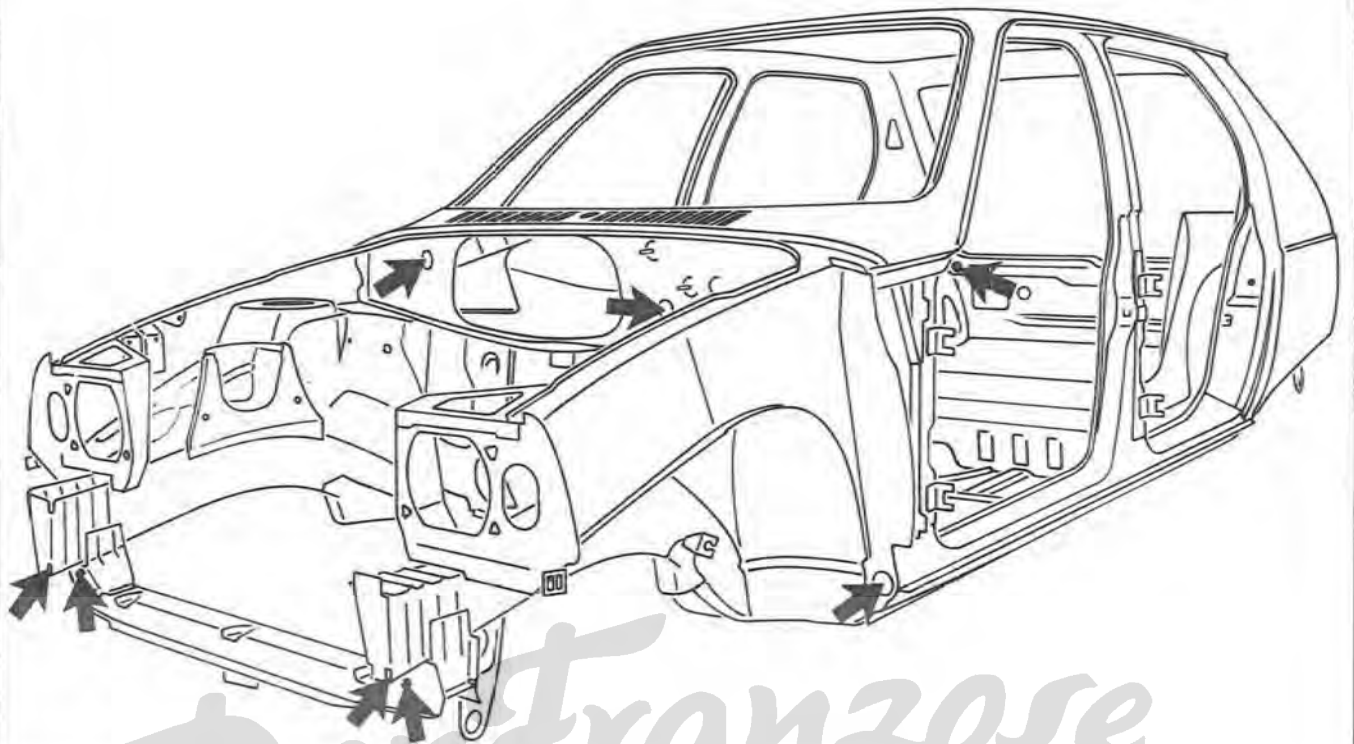

V 80-66

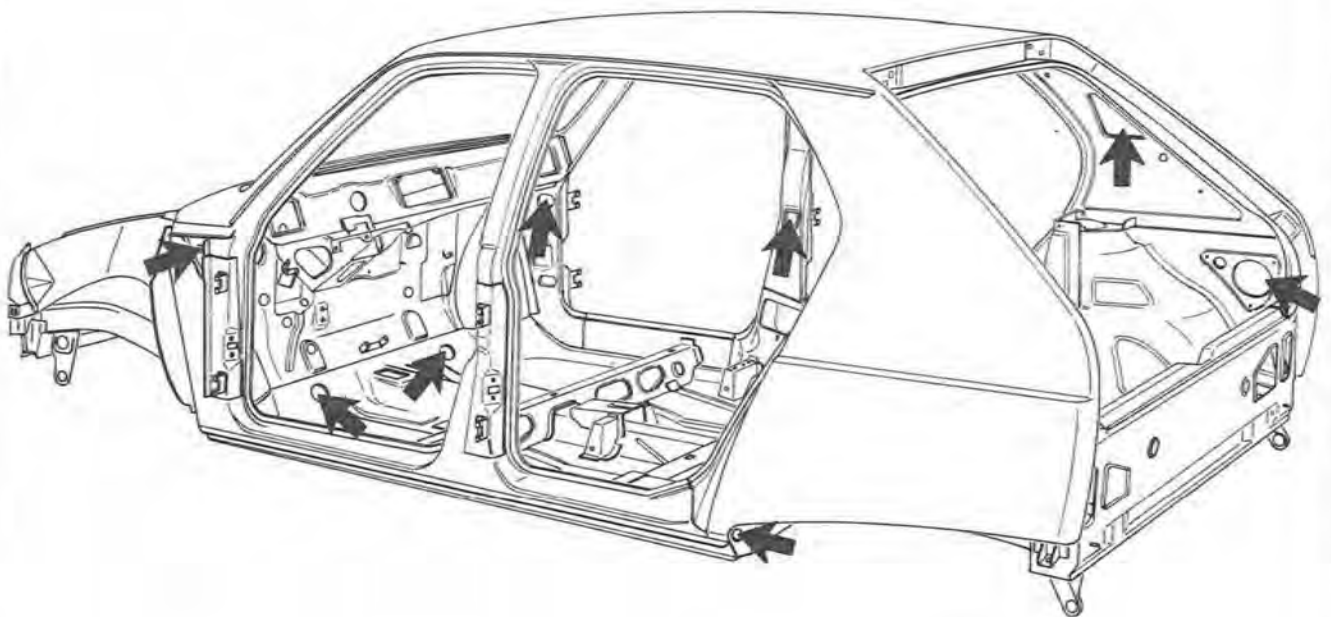

V 80-67

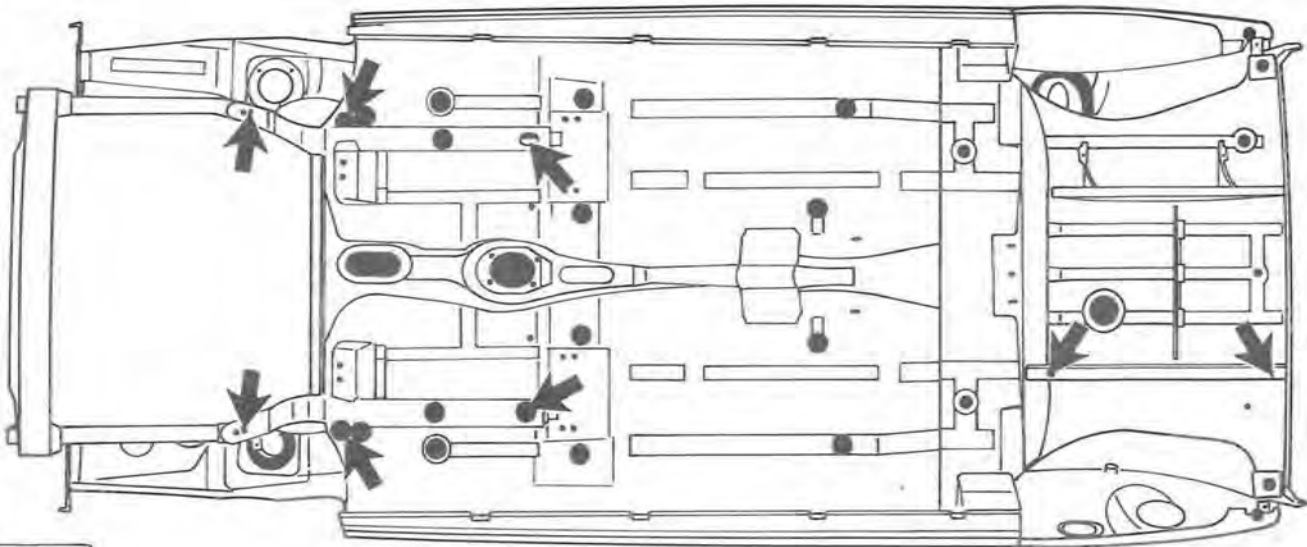

V 80-85

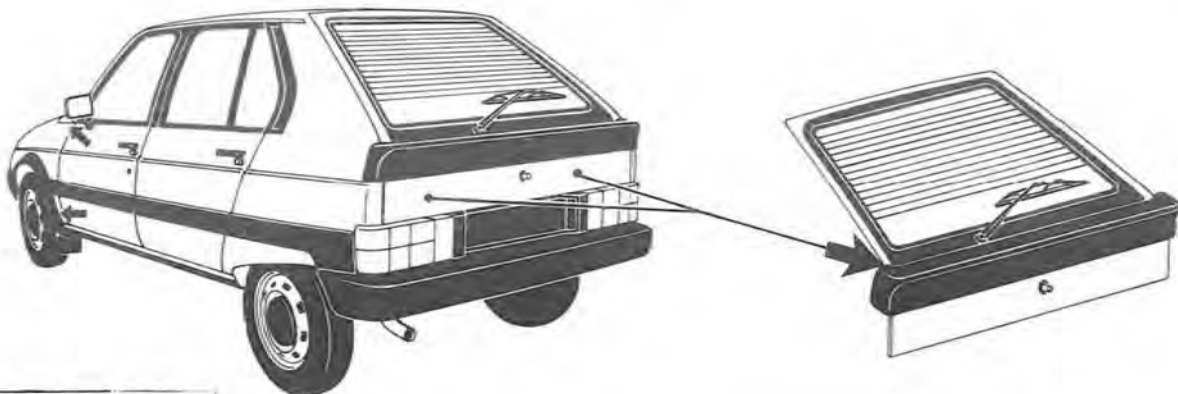
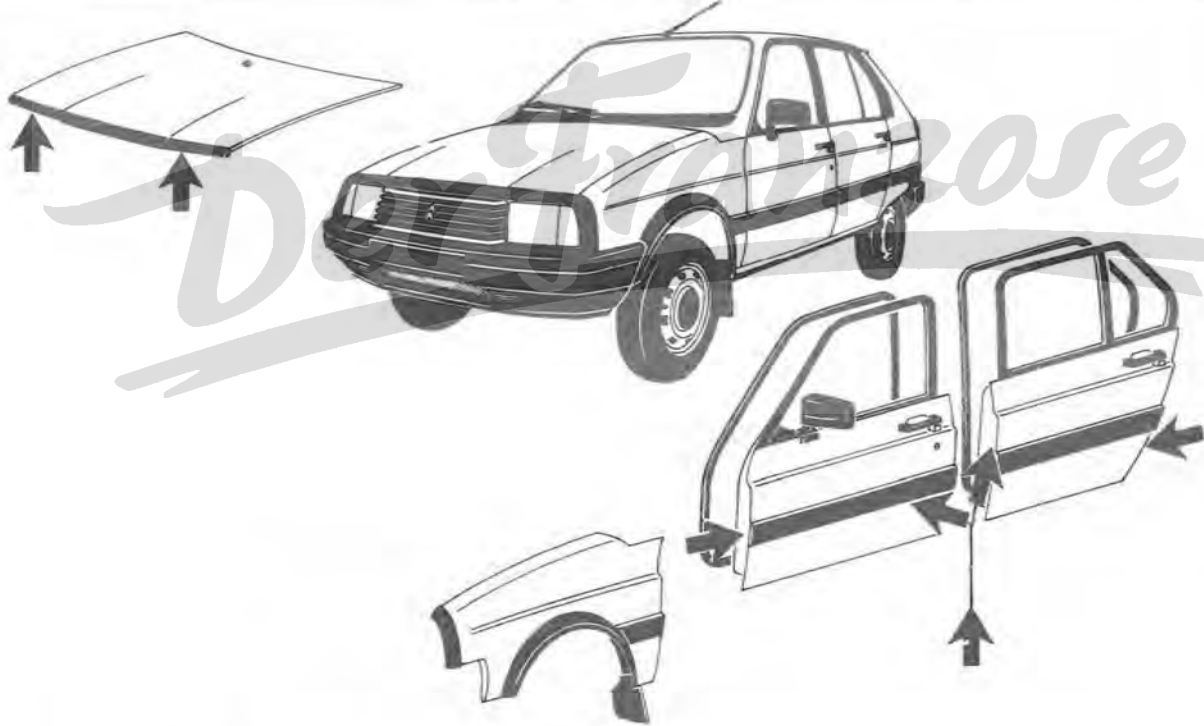

V 80-73/V 80-75i V 80-73

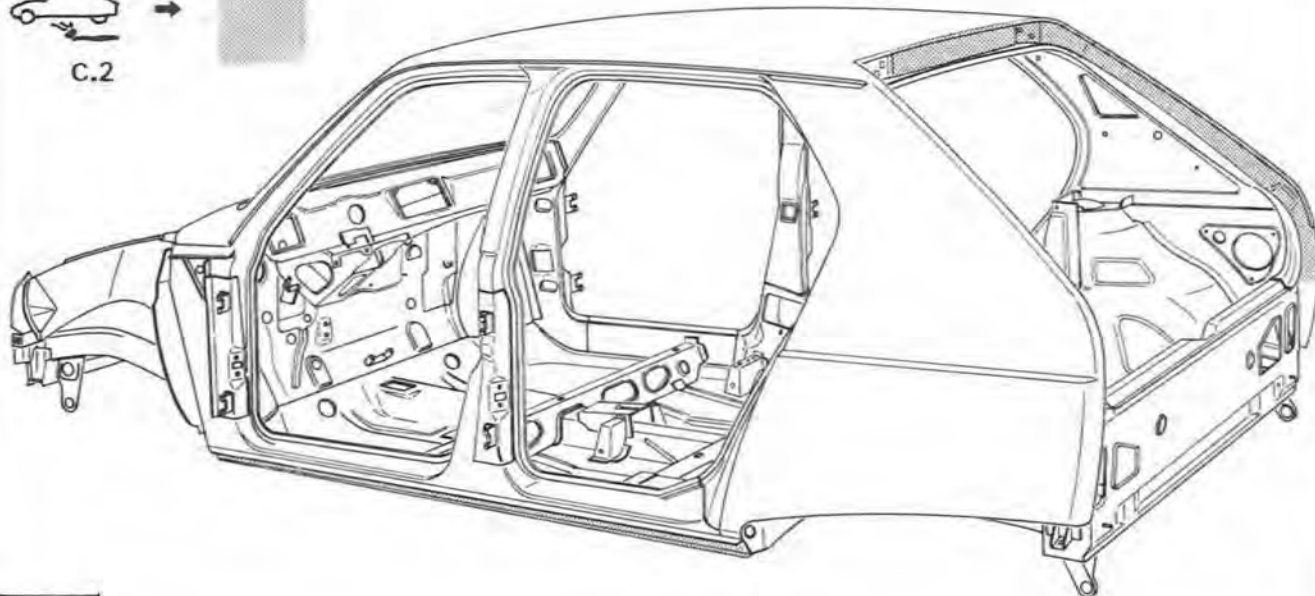
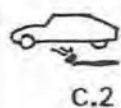

V 80-67

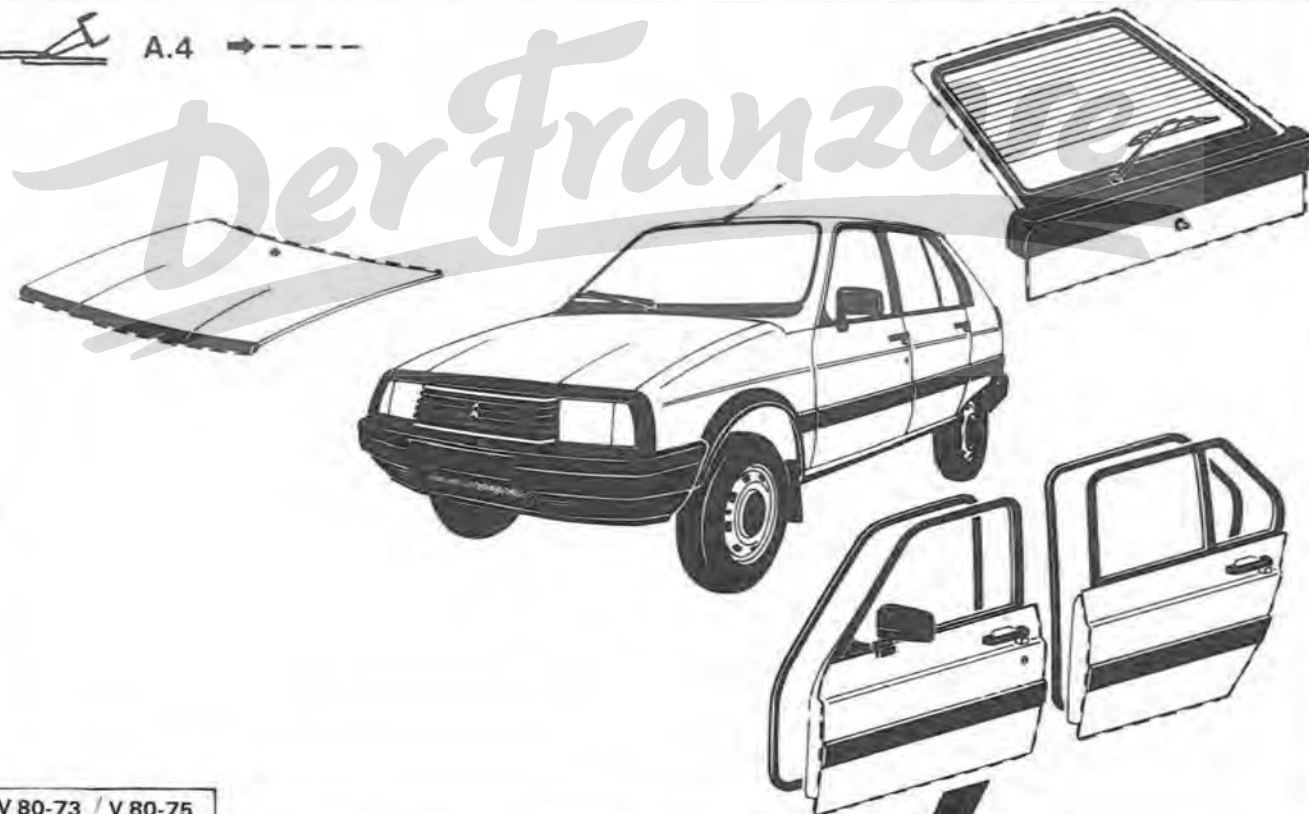
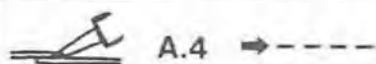

V 80-73 / V 80-75

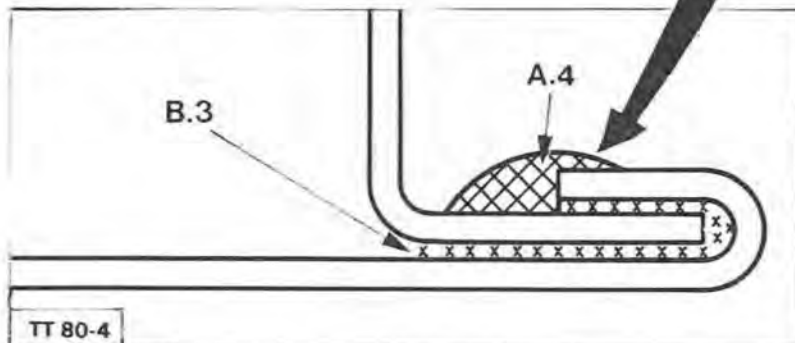

TT 80-4



A1

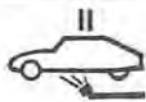

C1



C2

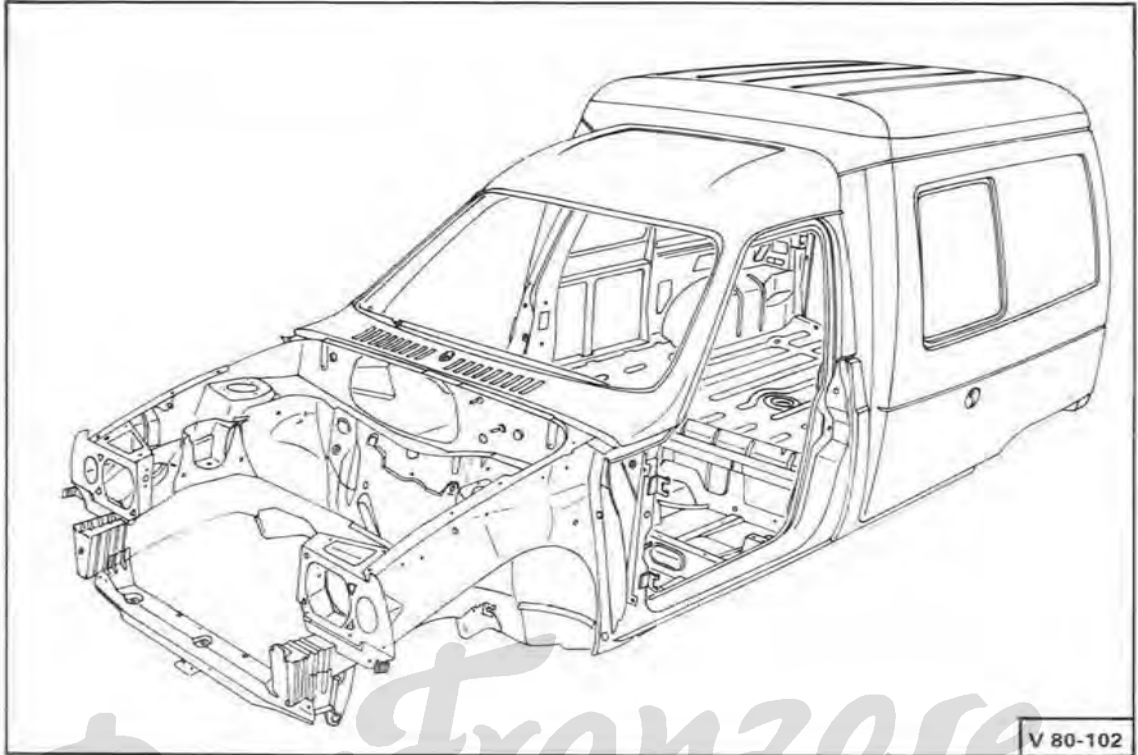
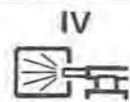

Der Franzose

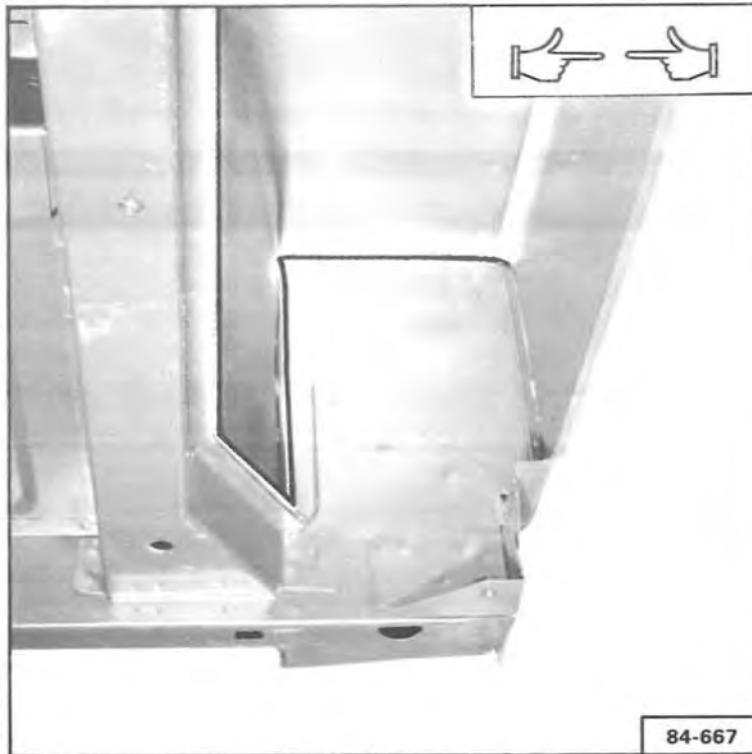
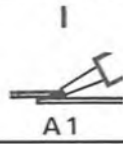



84-645



84-657

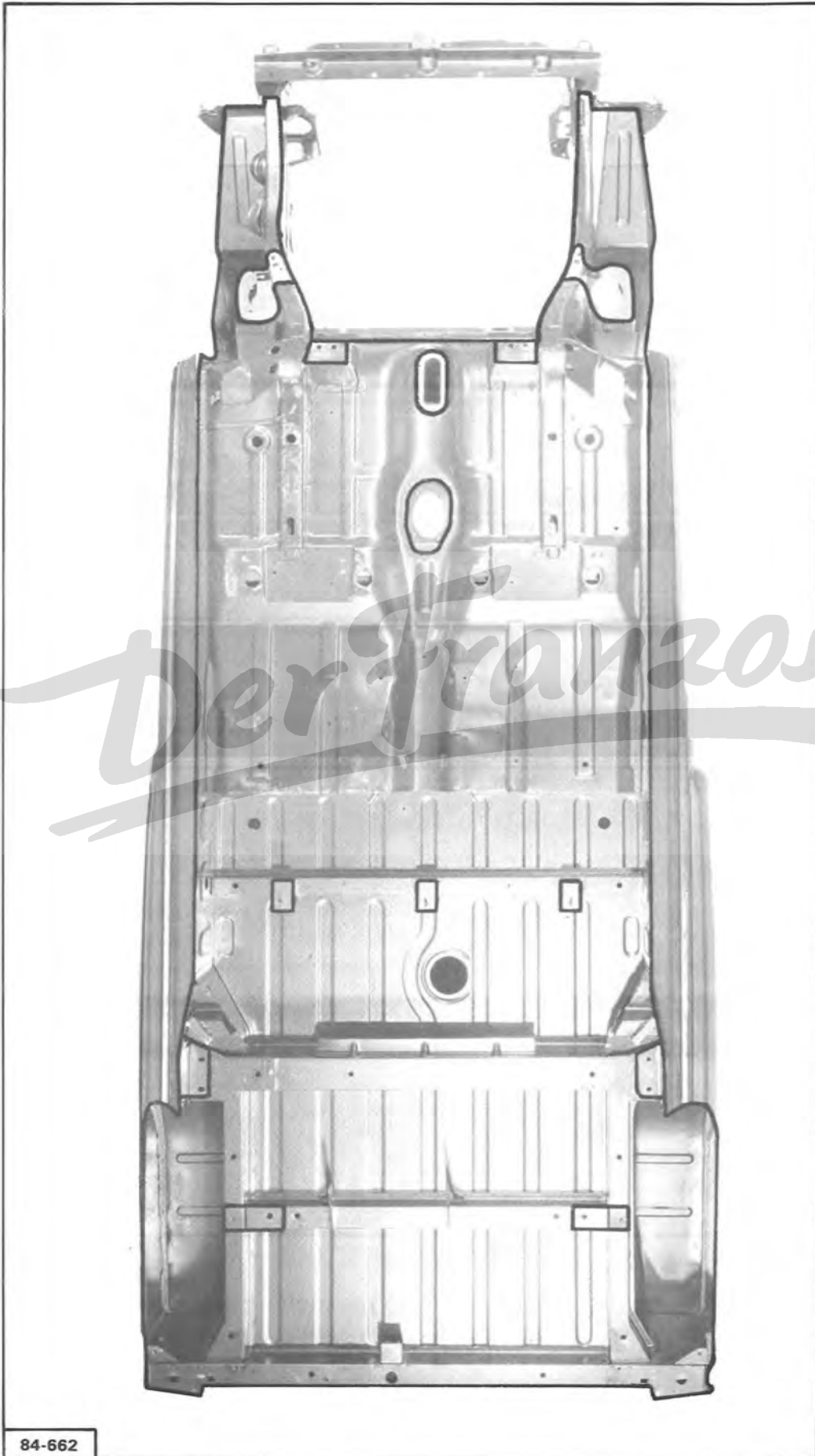
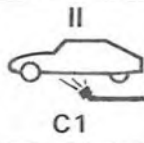



84-657

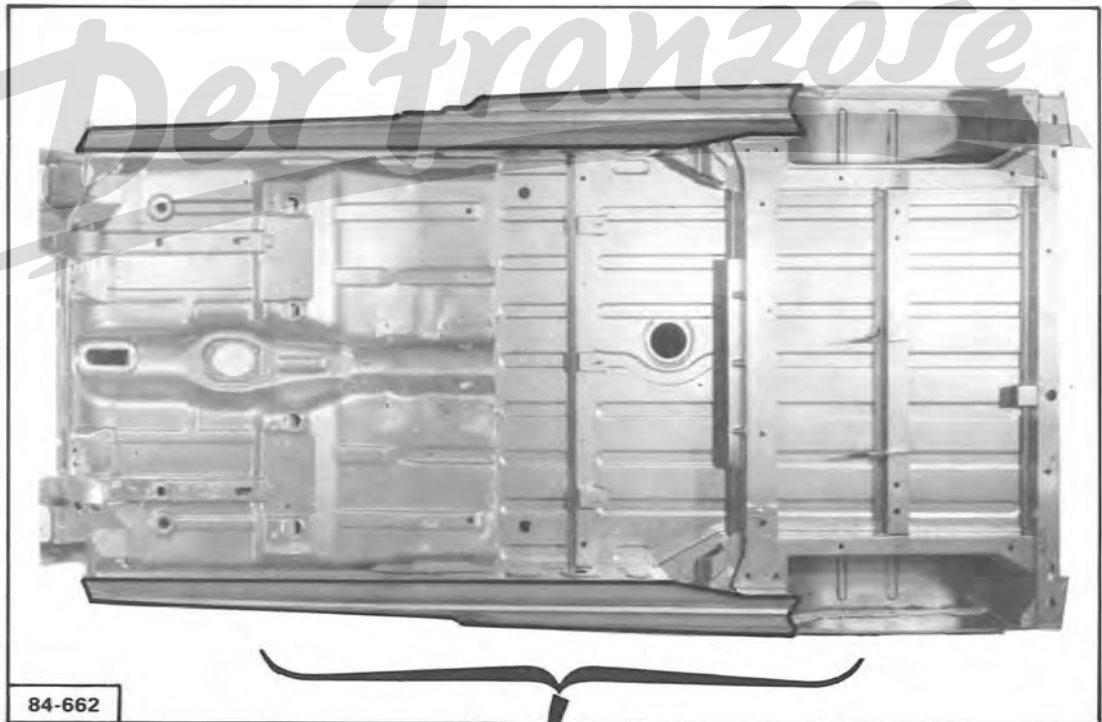

84-662

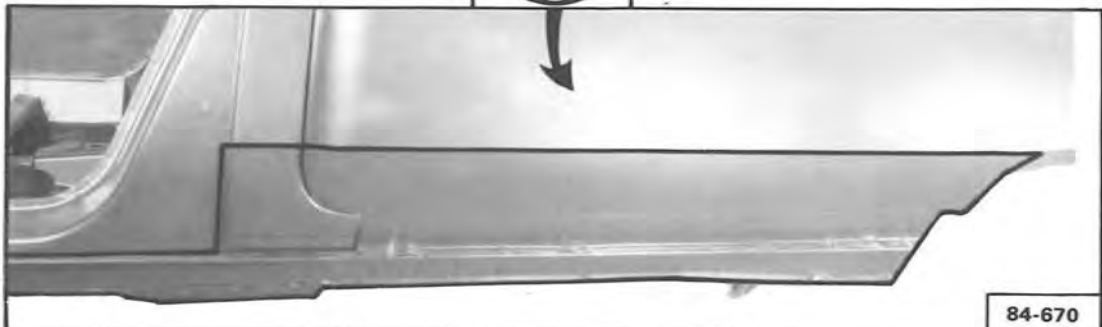

84-670

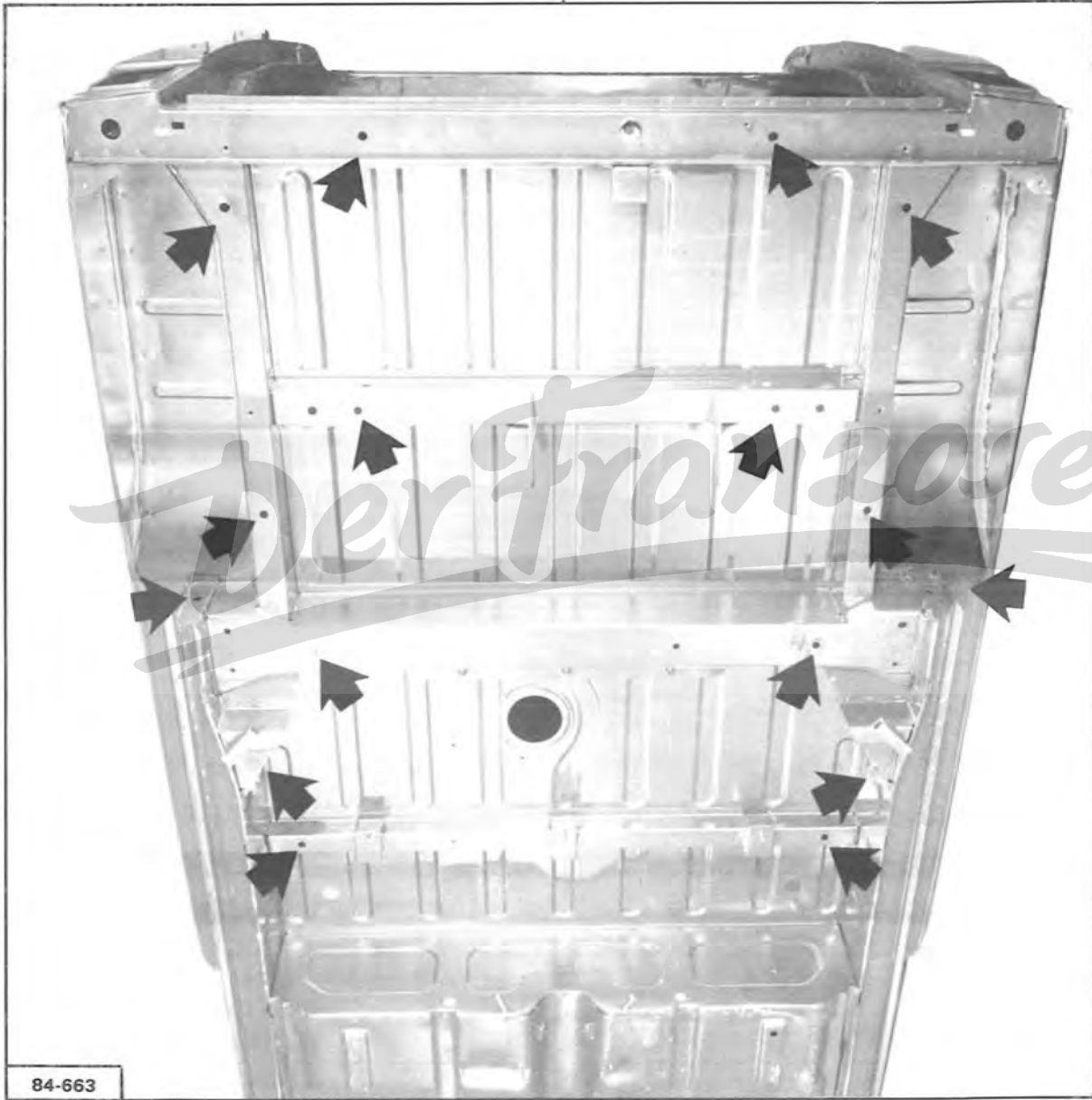



WM. CITR. 307300
VD

WM. CITR. 307308
VD.Di

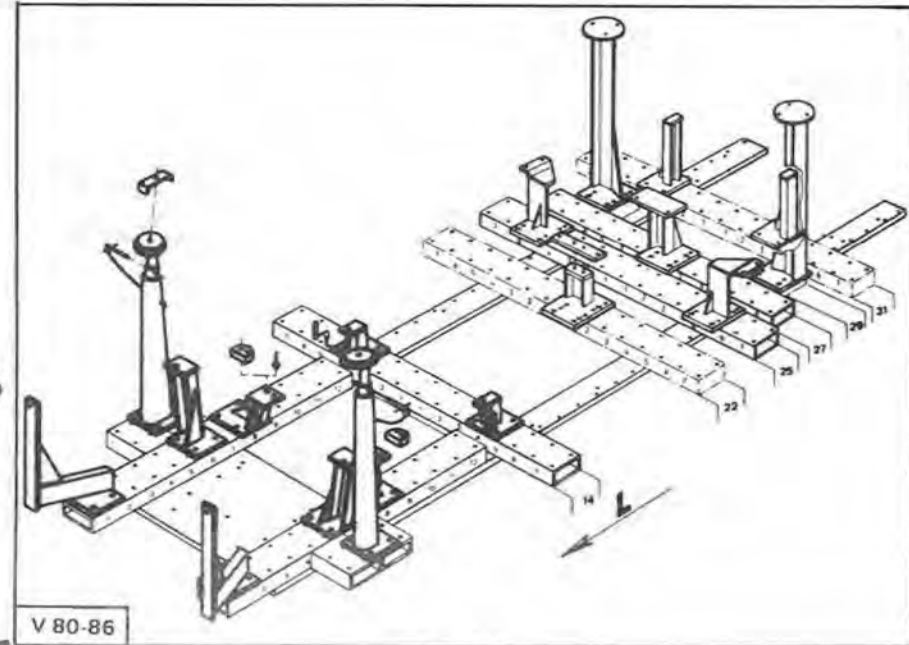
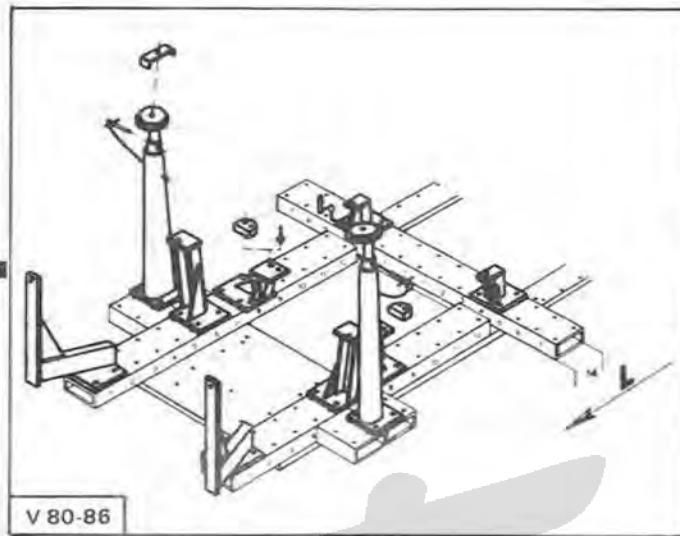
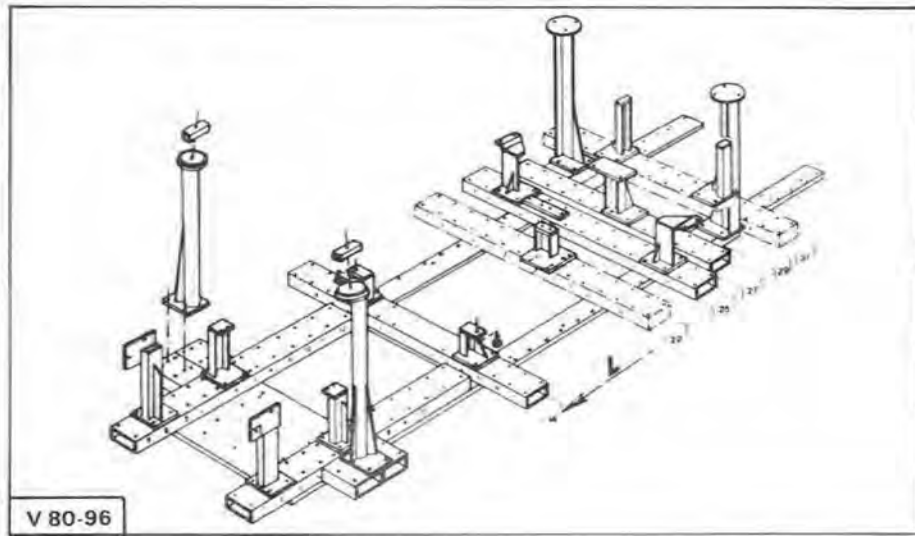

TT 80-12
TT 80-13

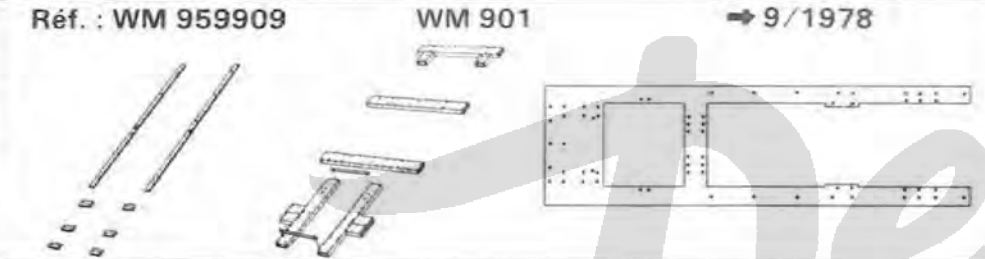

TT 80-14

TT 80-12

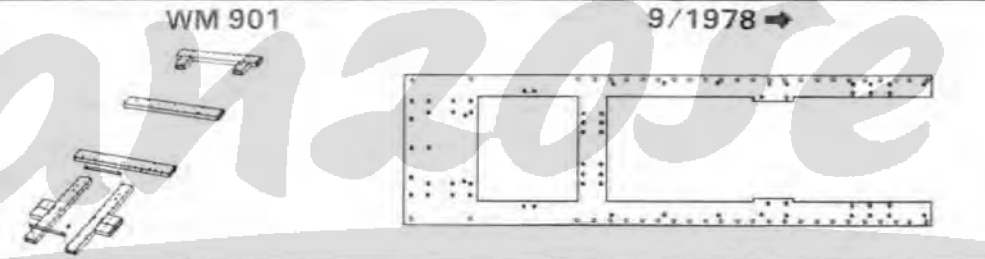

TT 80-14

WH. CITR. 231300
VD

WH. CITR. 231305
VD.Di

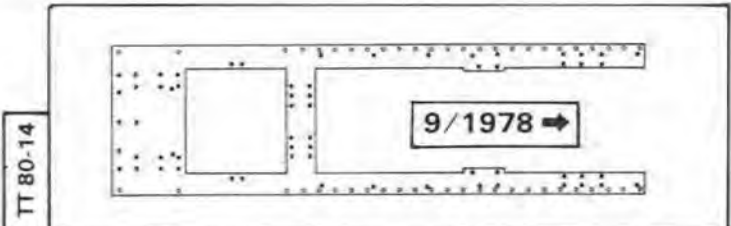
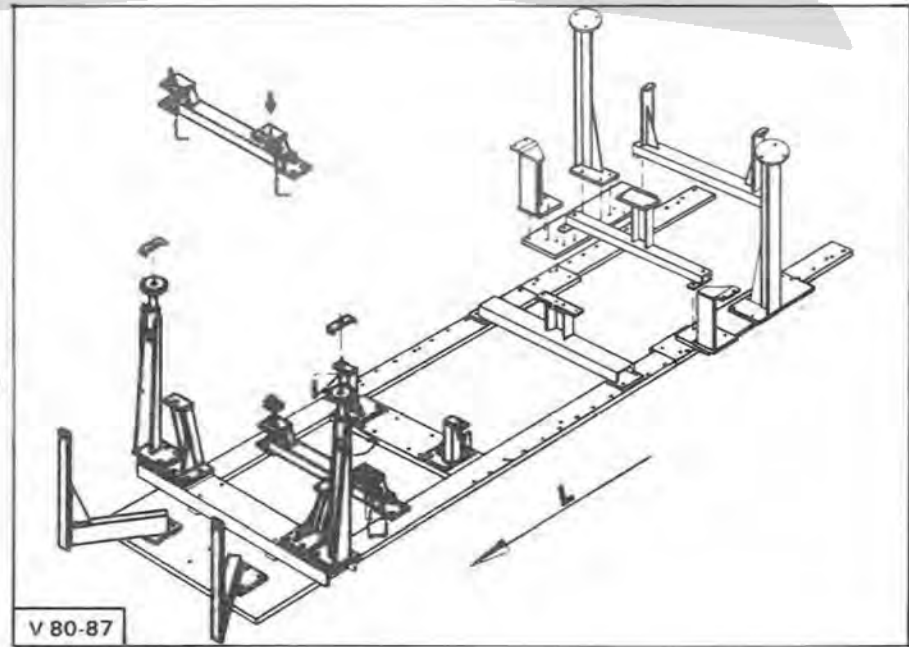
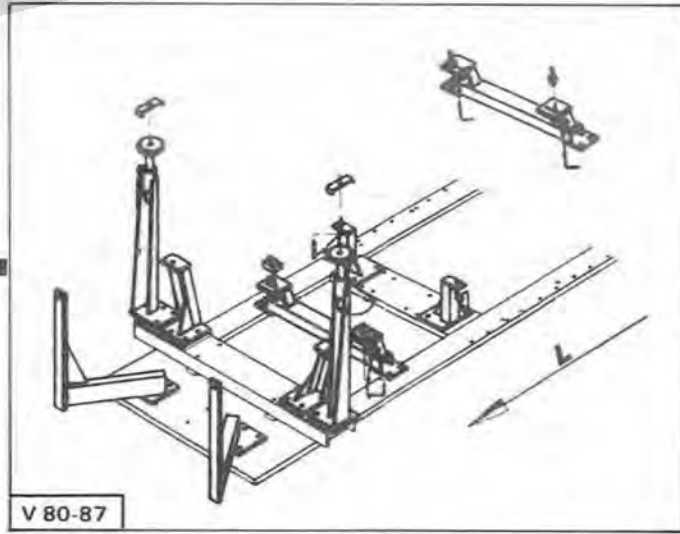
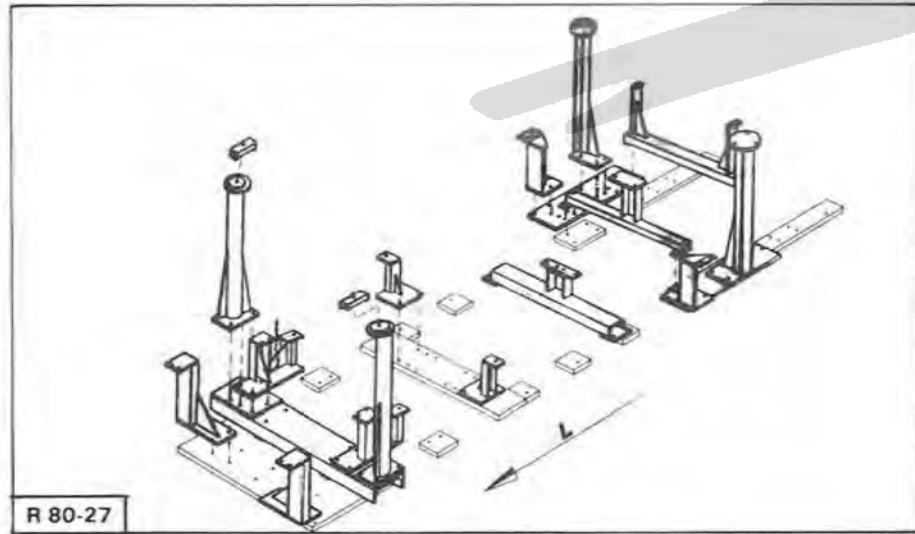

TT 80-14

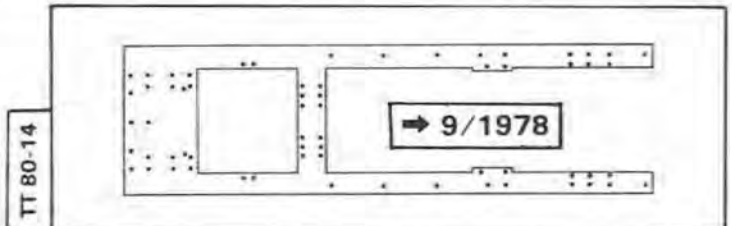

TT 80-14



WM. CITR. 307320
VD

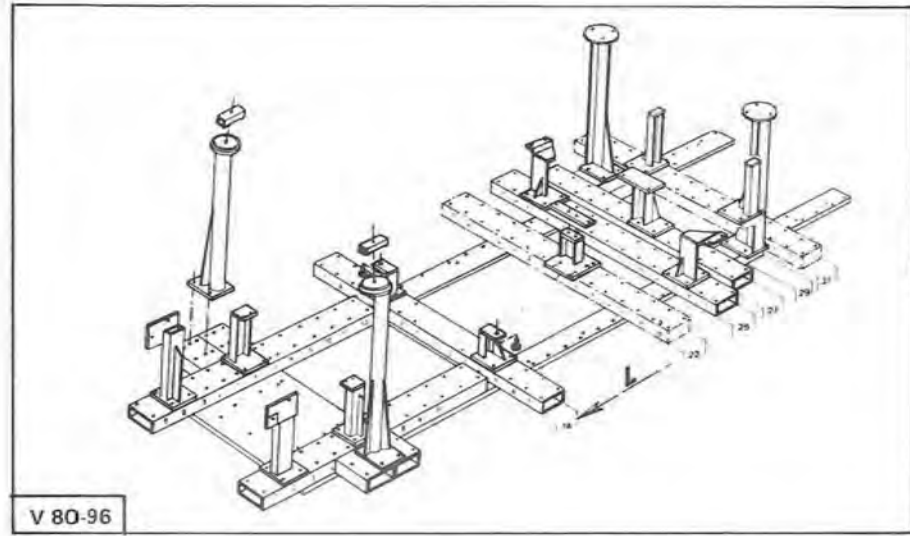

V 80-96

WM. CITR. 307307
VDU

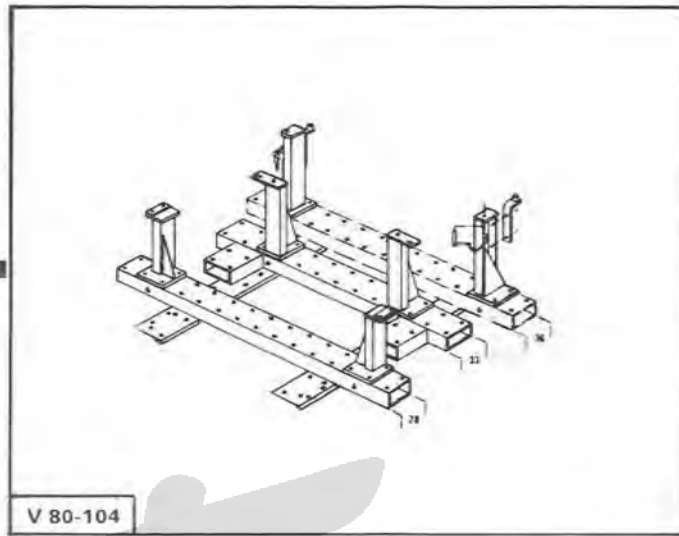

V 80-104

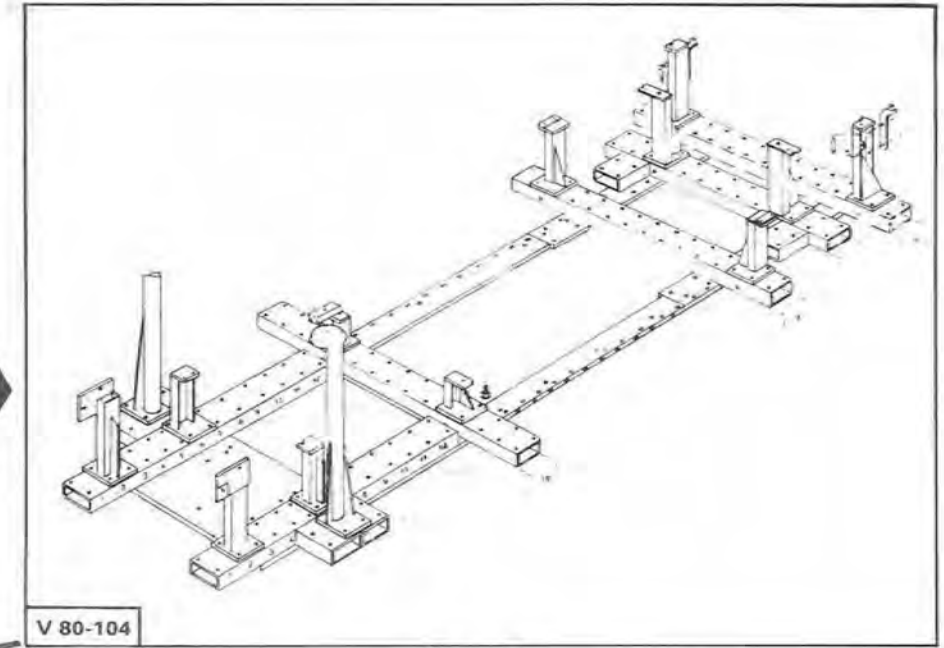

V 80-104

Réf. : WM 95909

WM 901

→ 9/1978

TT 80-12
TT 80-13

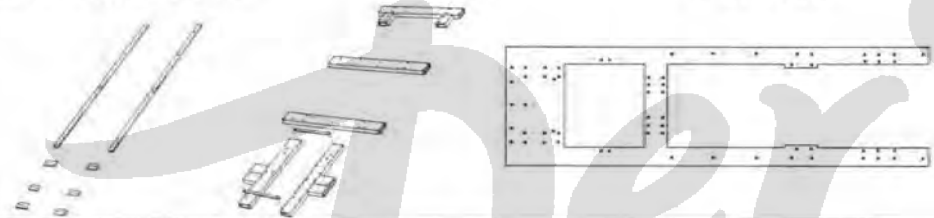

TT 80-14

WM 901

9/1978 →

TT 80-12

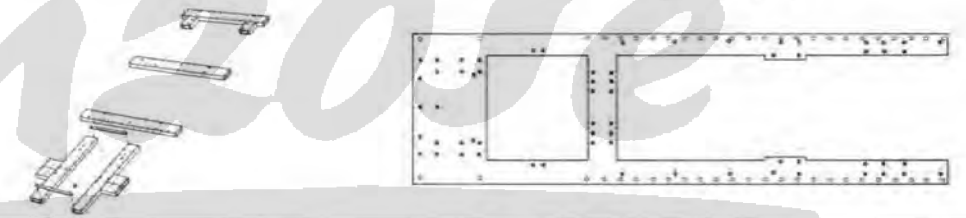

TT 80-14

WM. CITR. 231300 + WM. CITR. 231308
VD

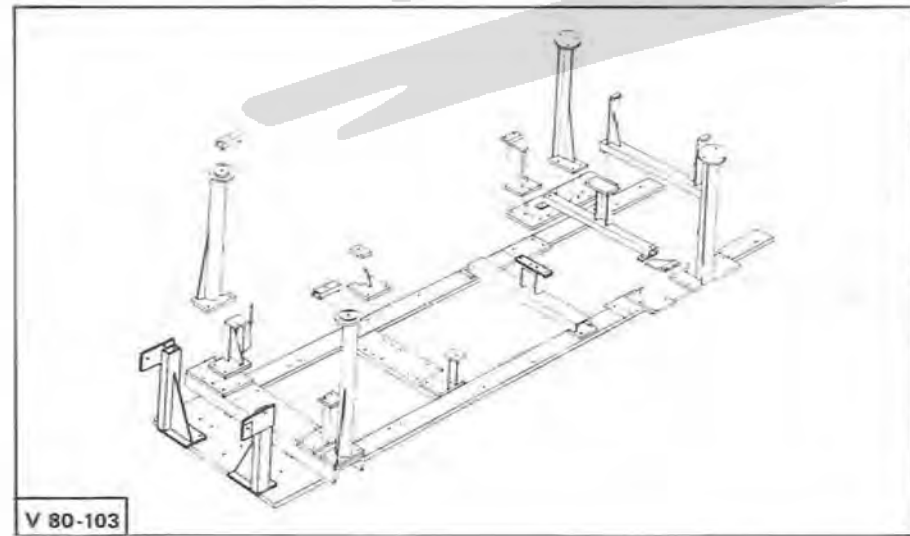

V 80-103

WM. CITR. 231304
VDU

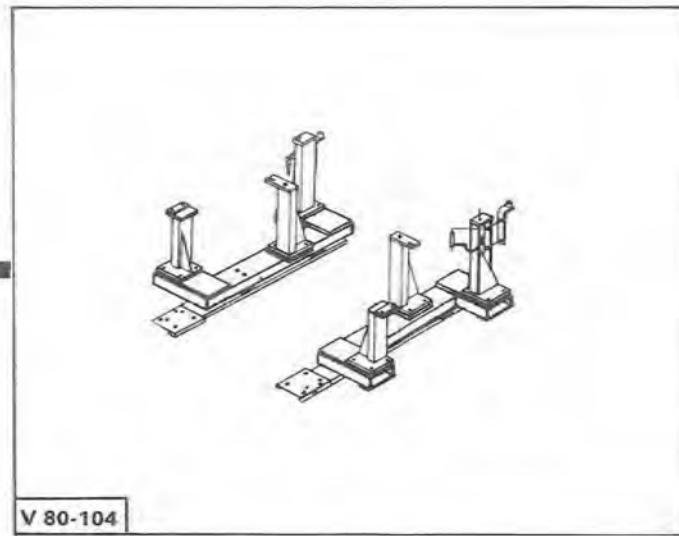

V 80-104

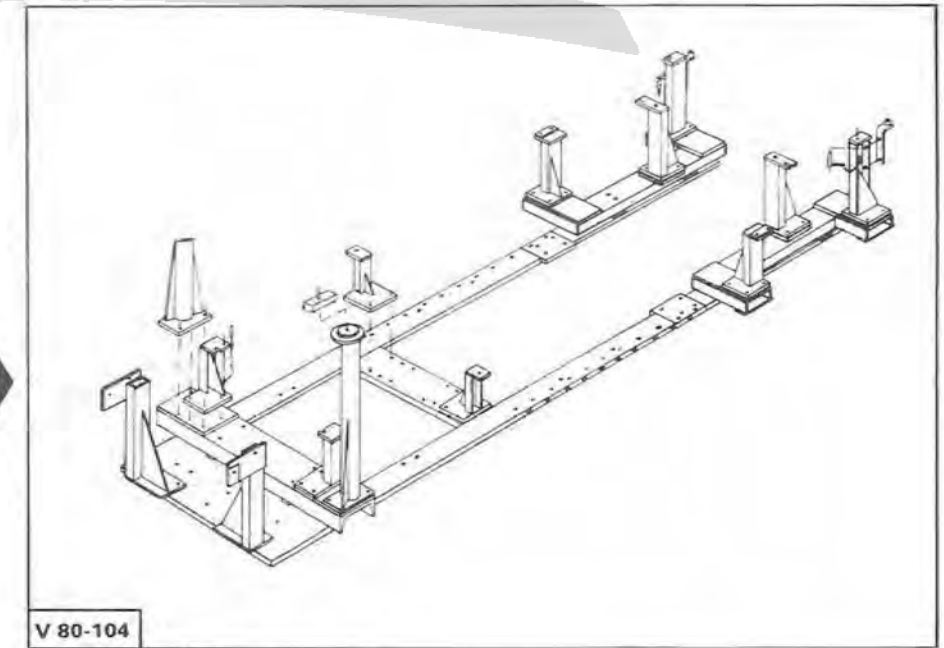

V 80-104

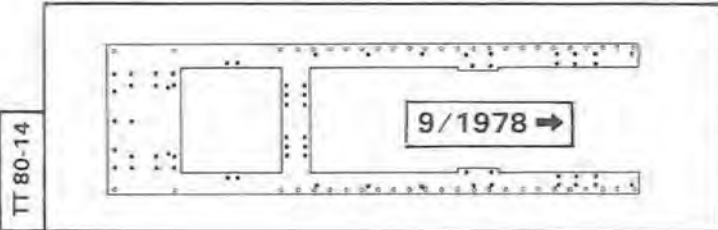

TT 80-14

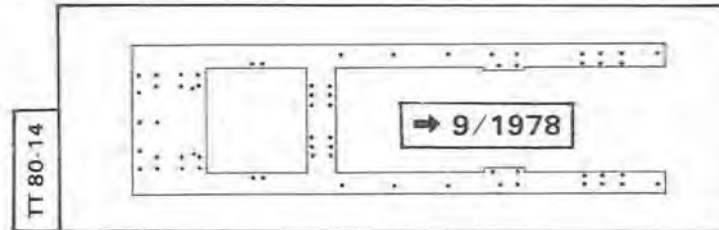

TT 80-14

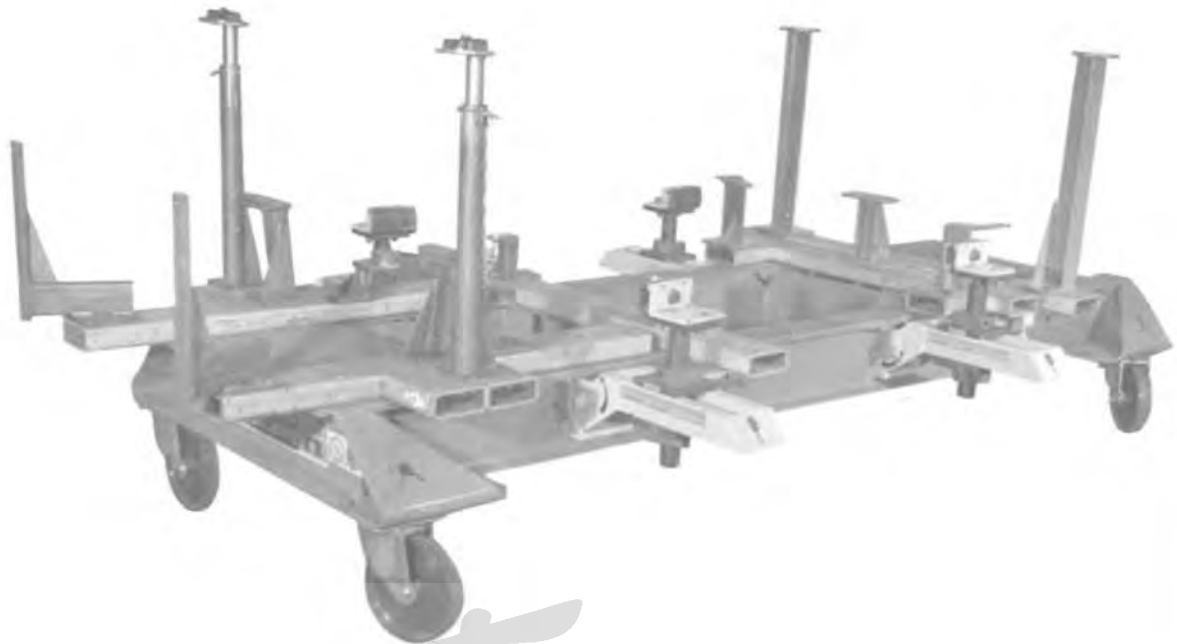
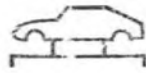

83-1316

Der Franzose



83-1315

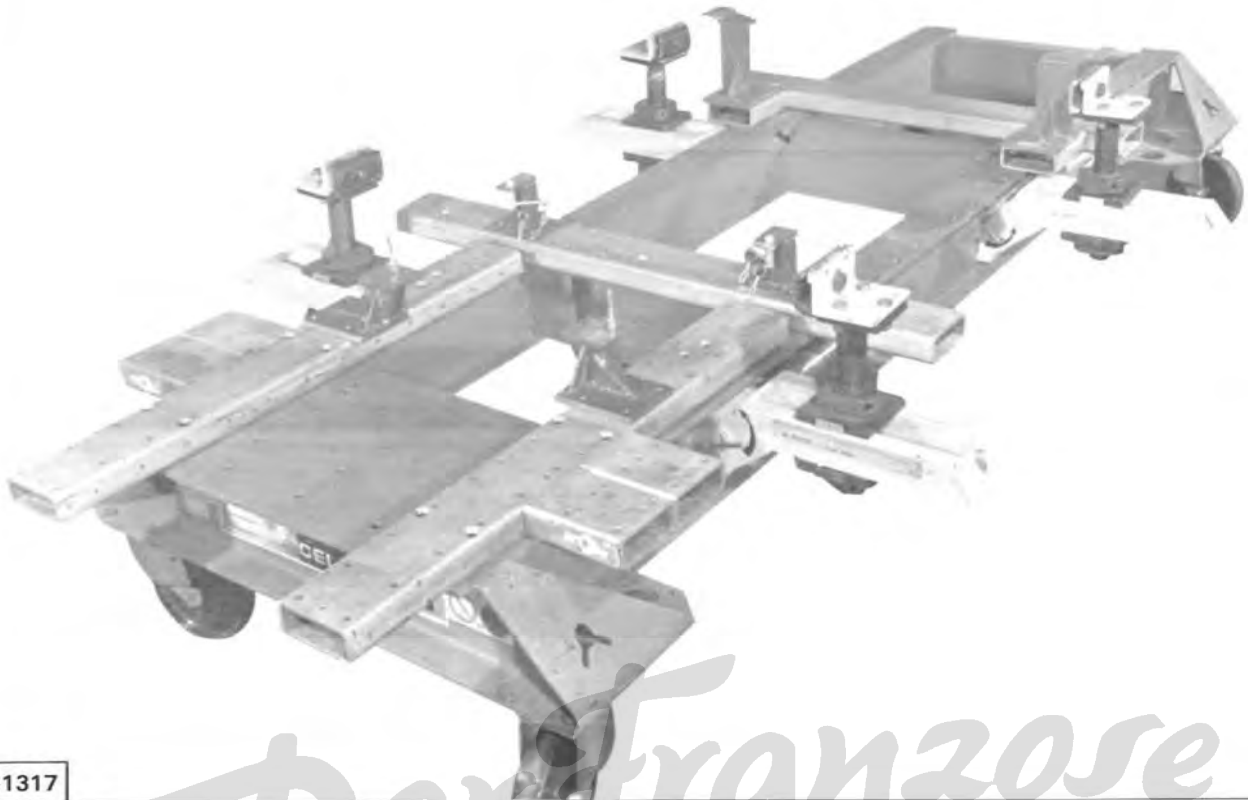

83-1317

Der Franzose



83-1323

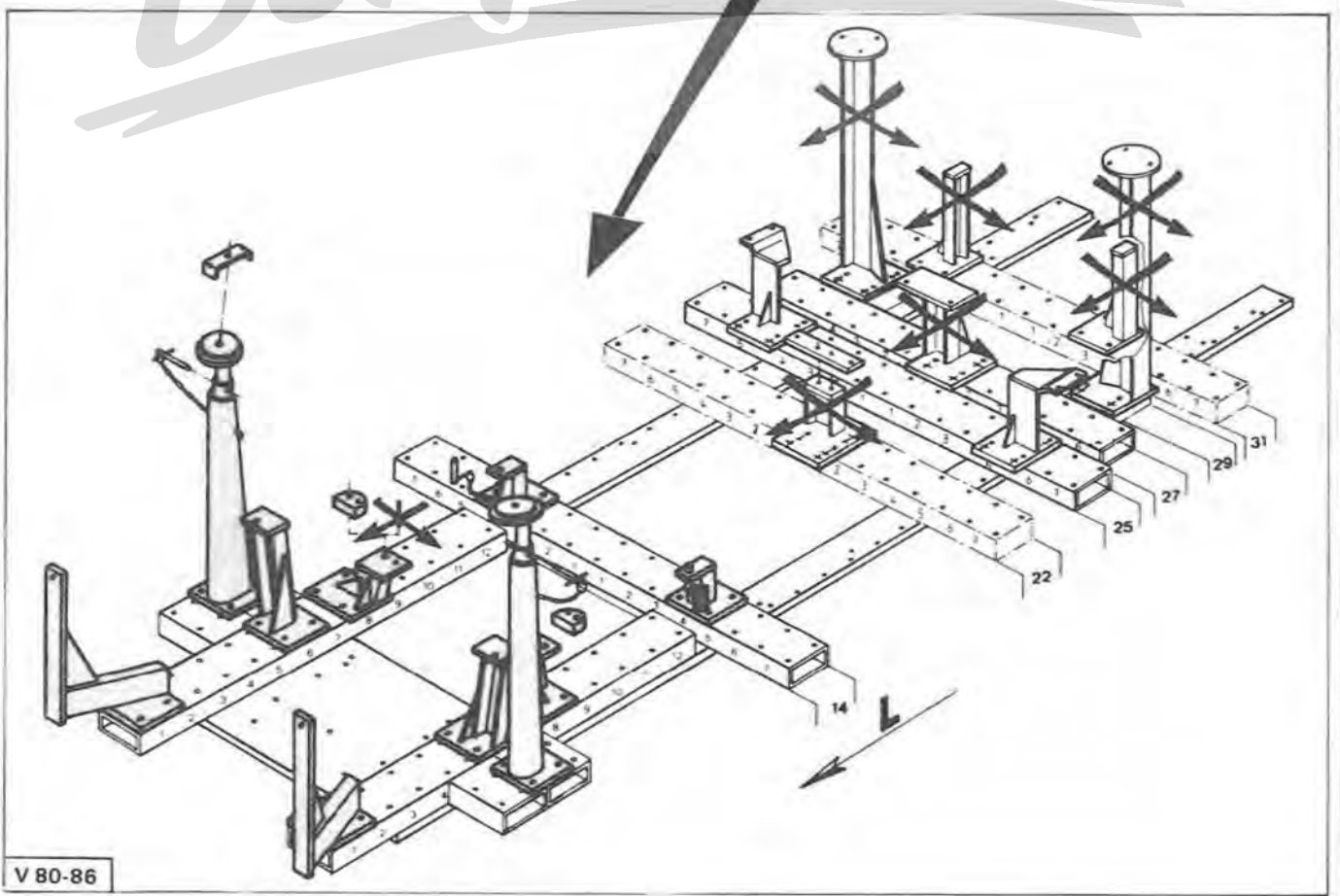
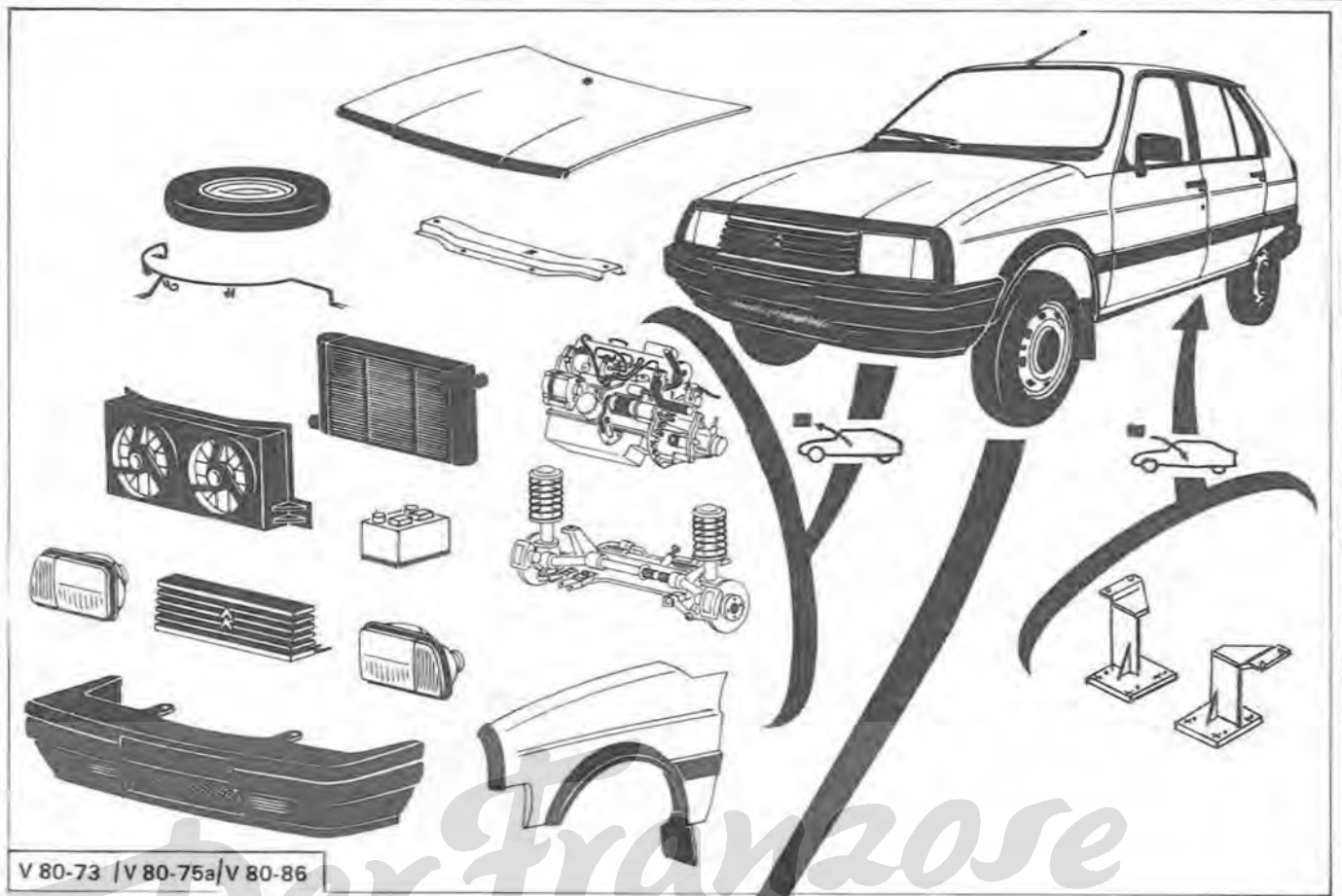
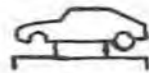

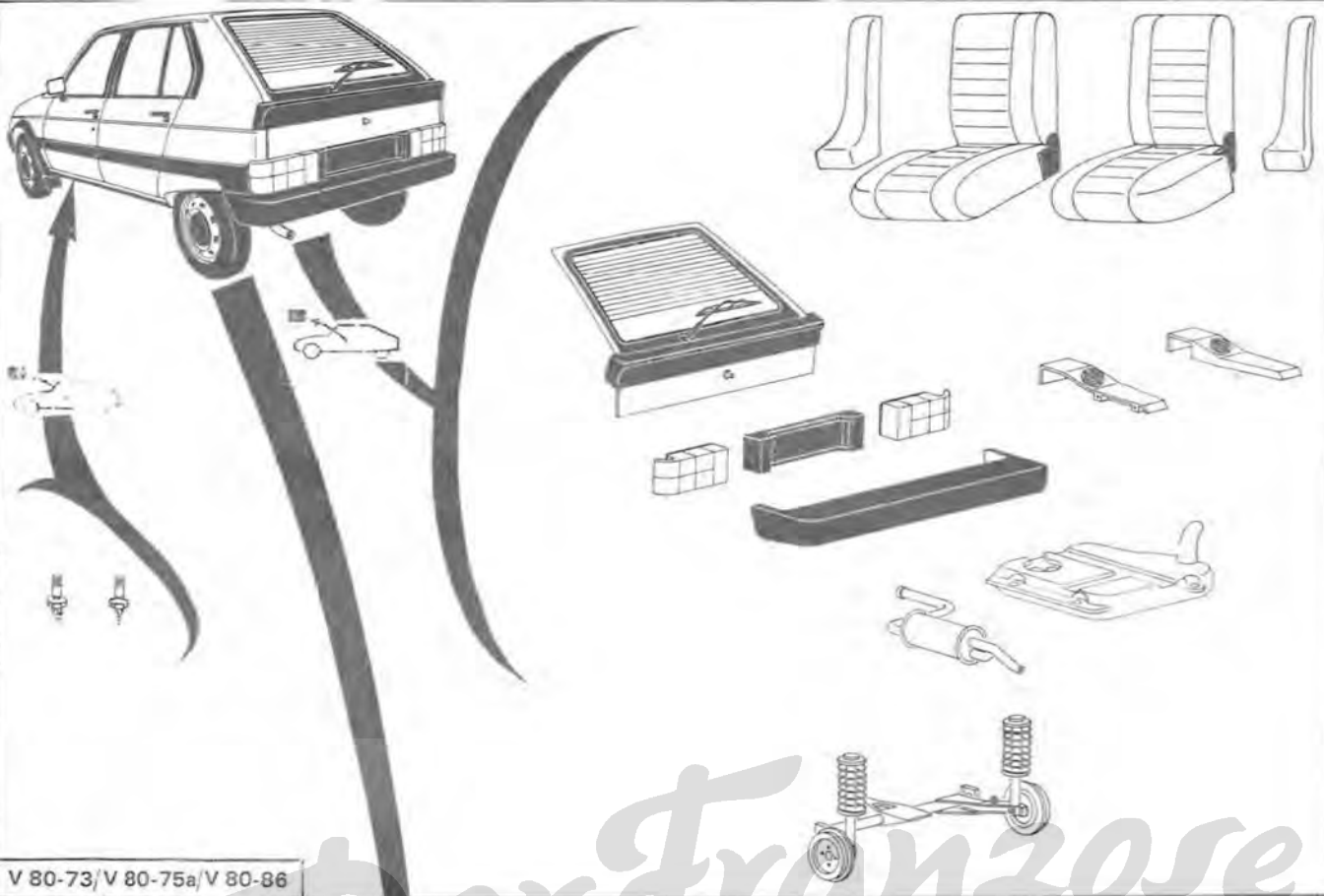
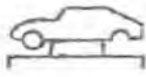

V 80-73/V 80-75a/V 80-86

Der Franzose

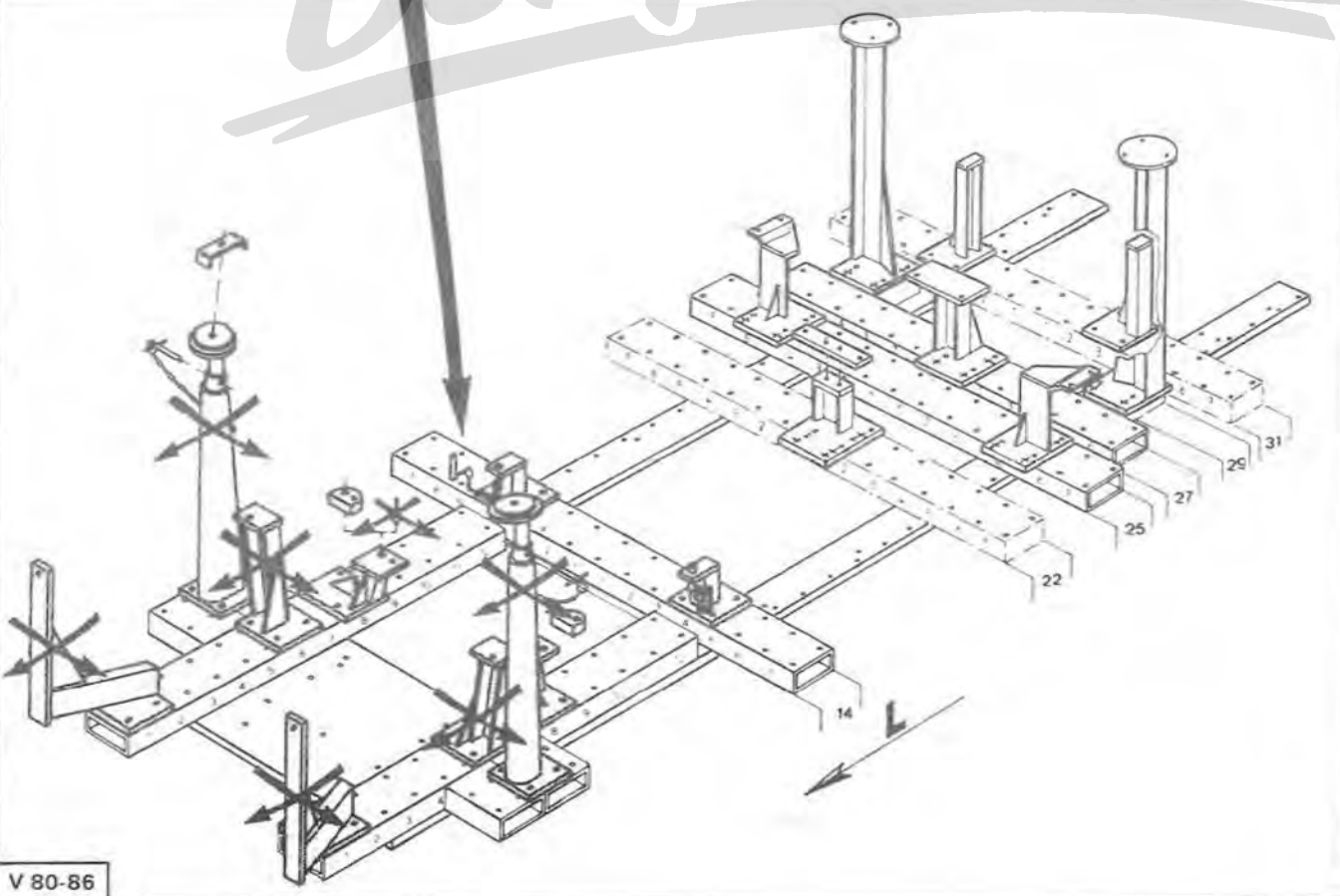

V 80-86



WM. CITR. 307307
VDU

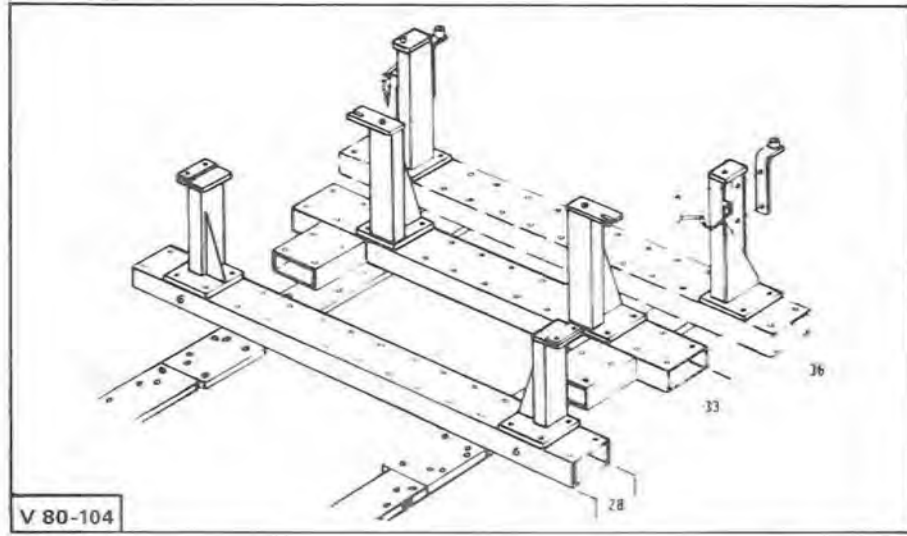

WM. CITR. 307308
VD.Di

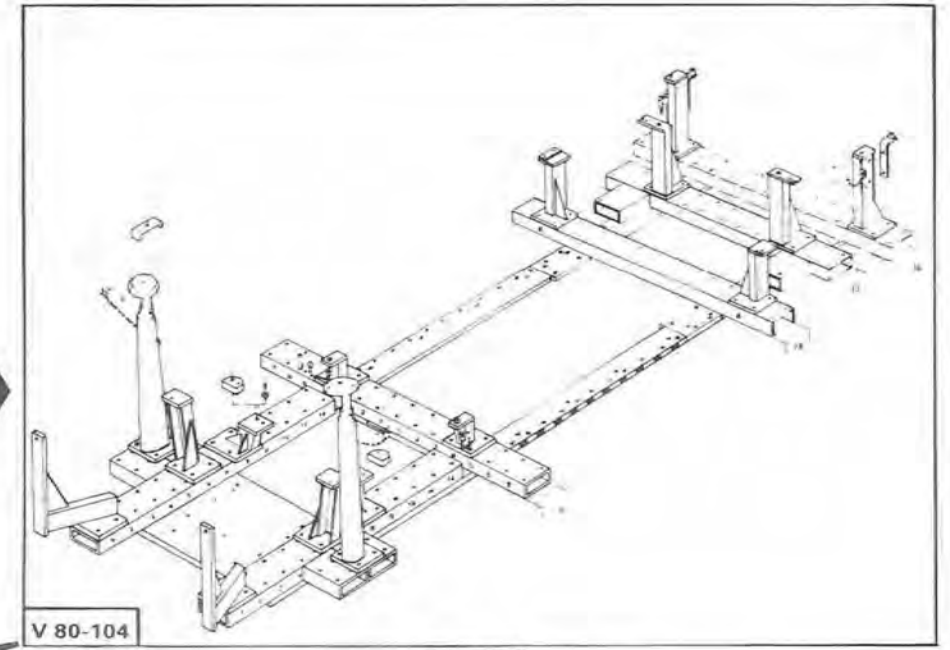
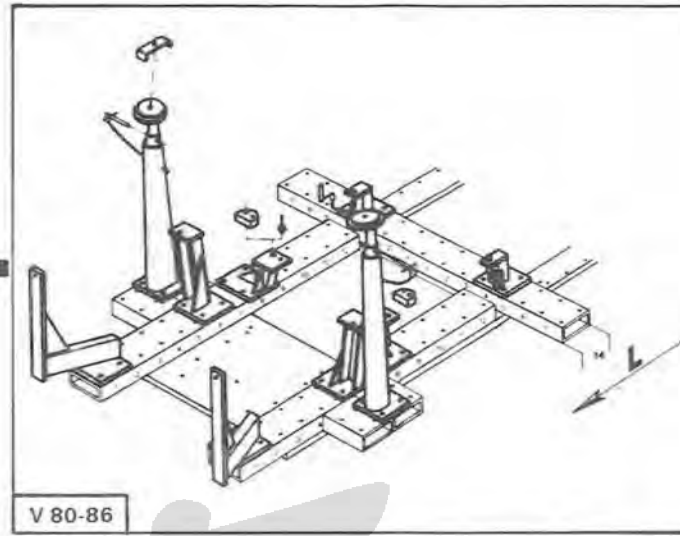

Réf. : WM 959909

WM 901

→ 9/1978

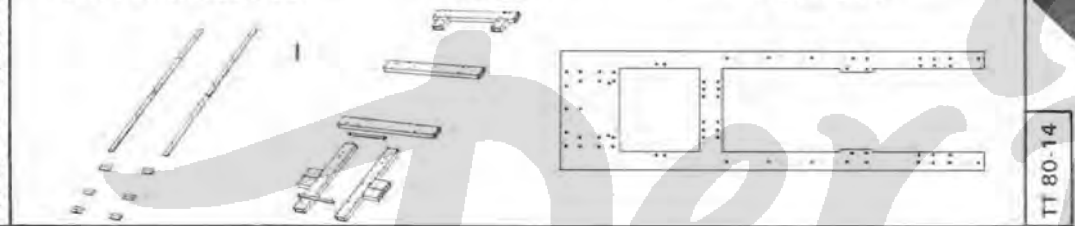

WM 901

9/1978 →

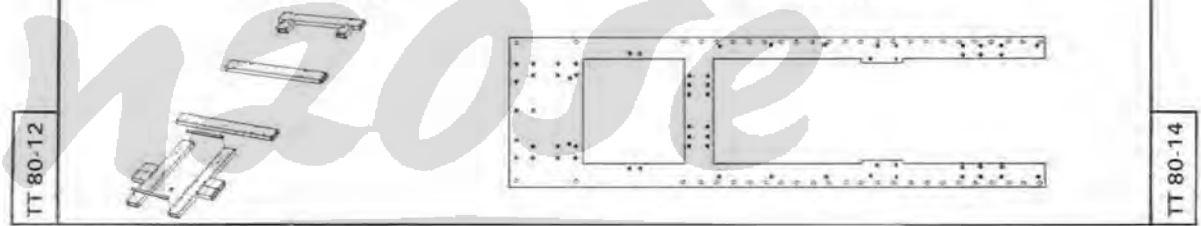

WM. CITR. 231304
VDU

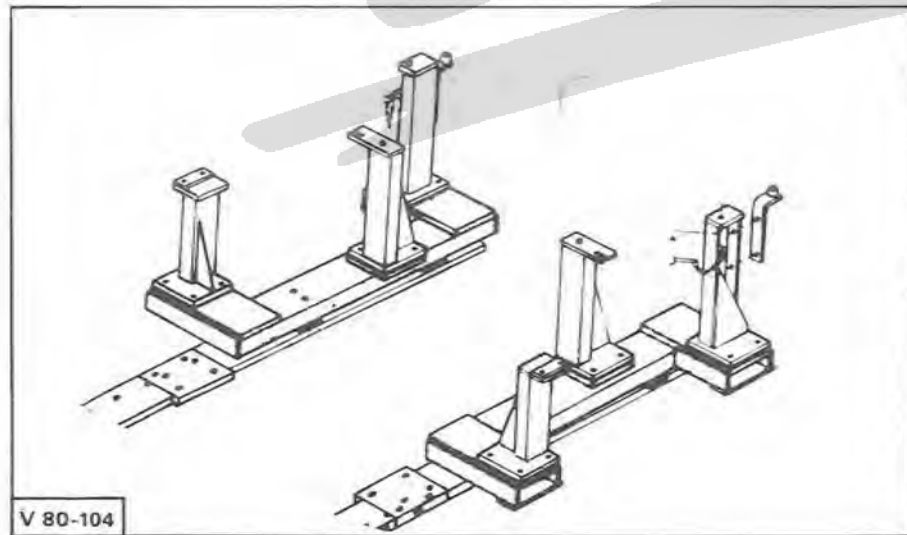

WM CITR. 231305
VD.Di

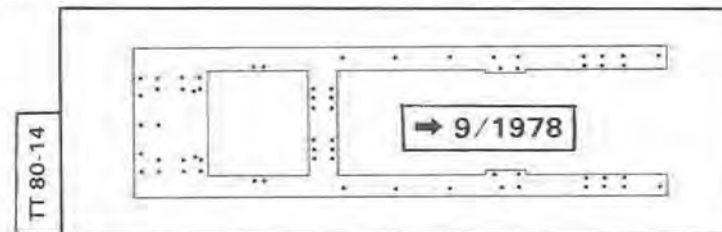
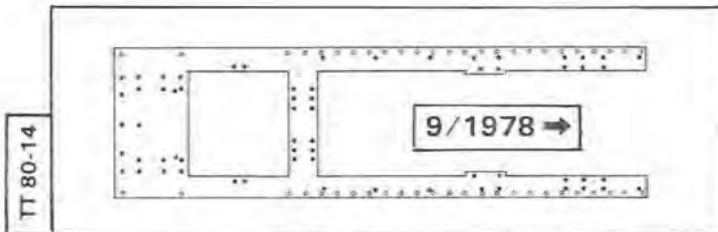
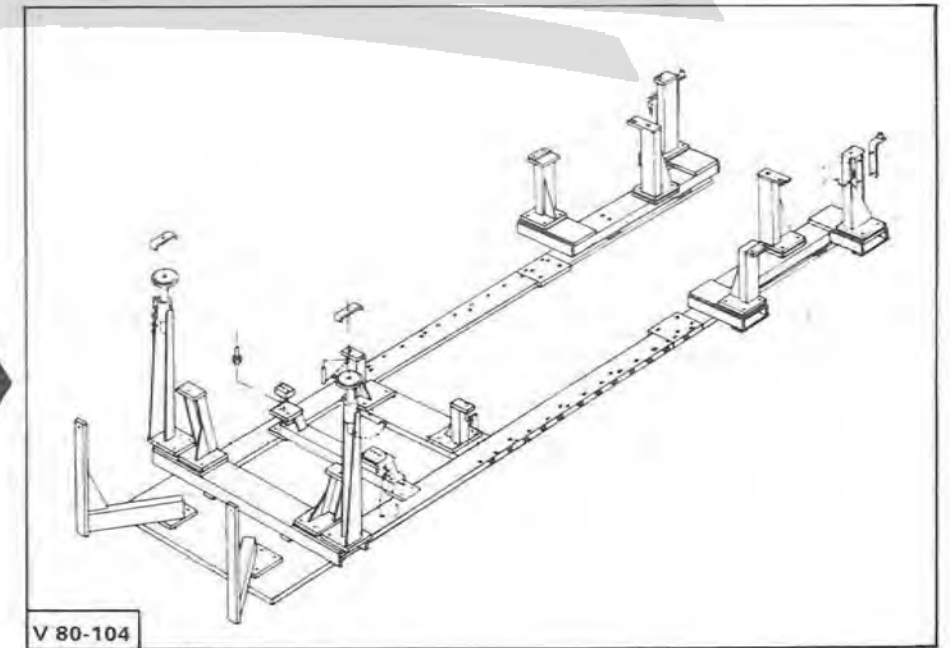
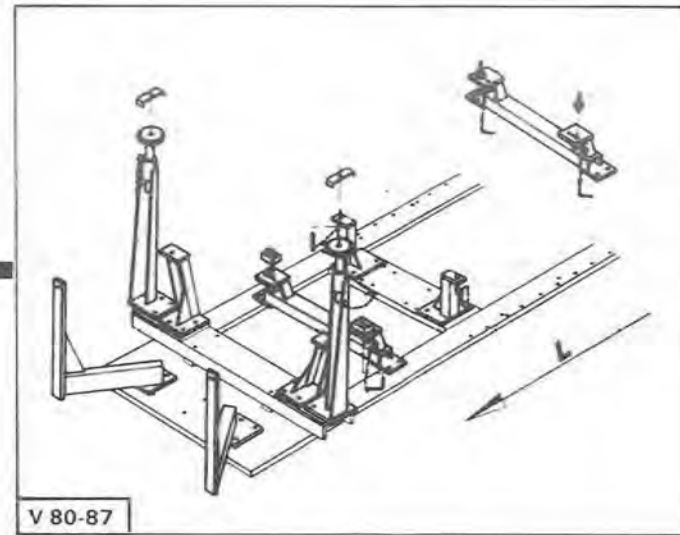

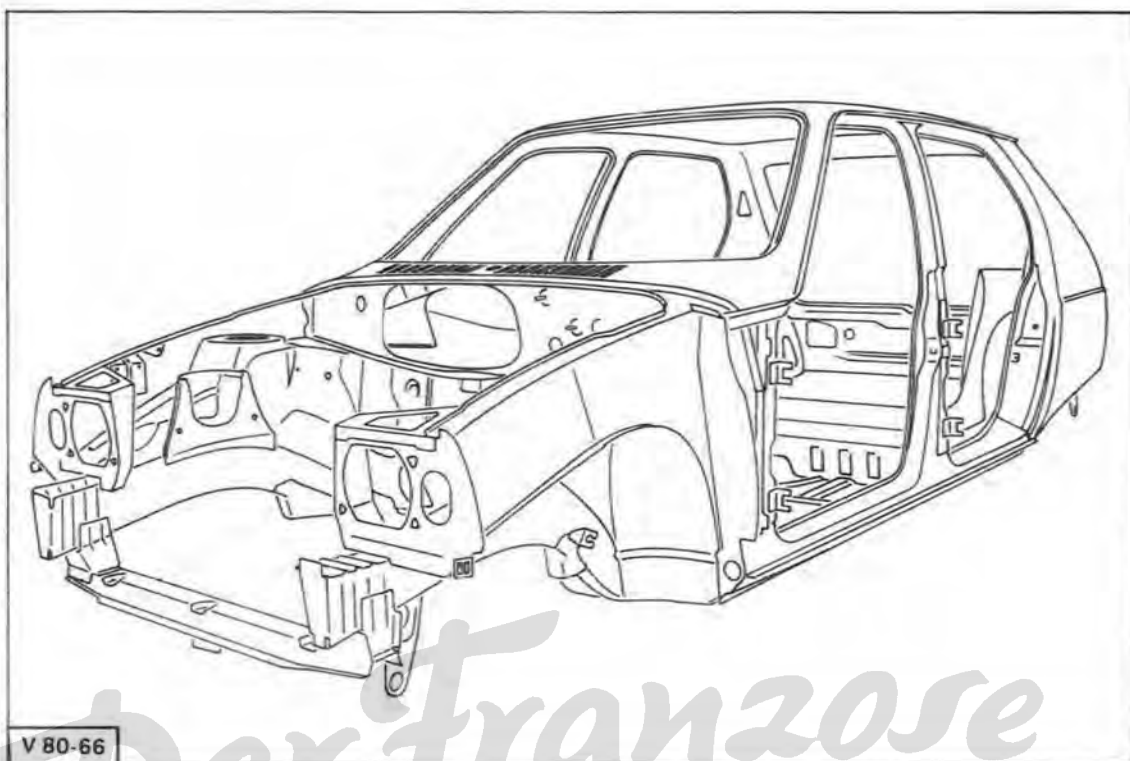

Der Franzose

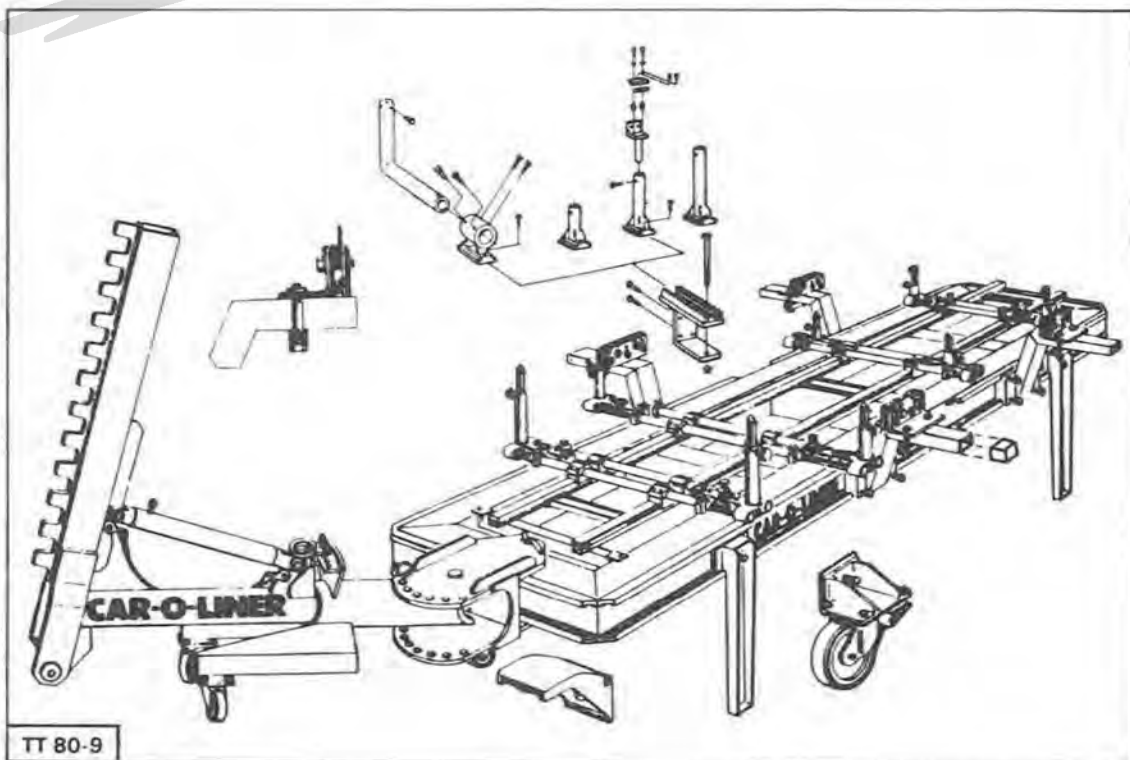

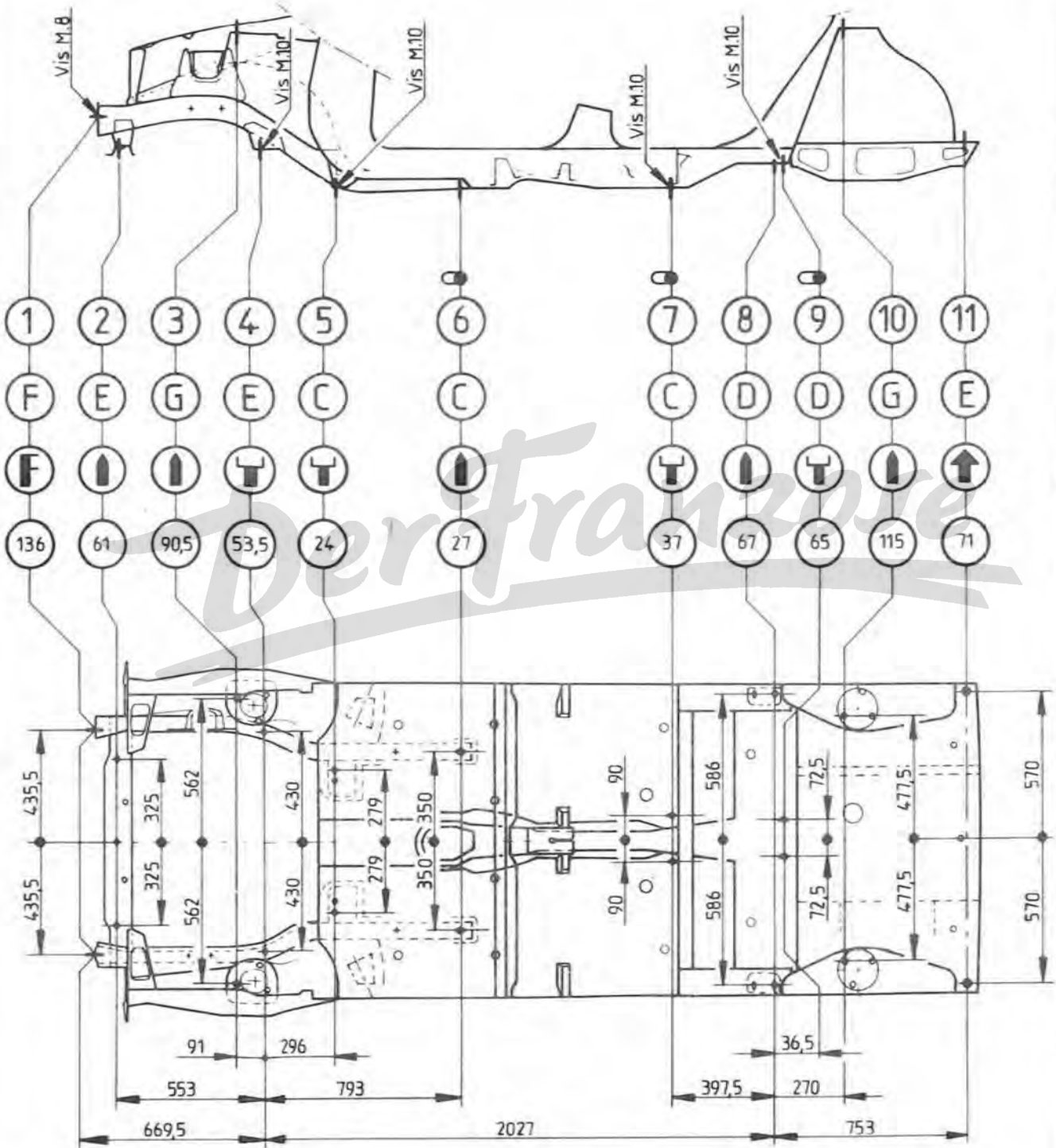

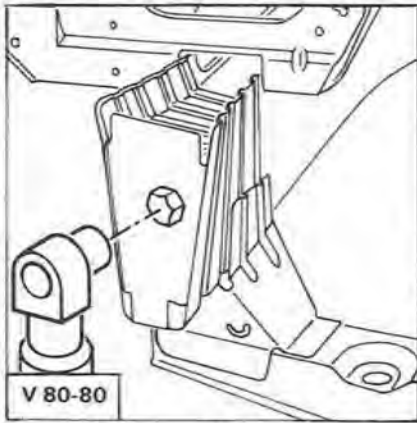
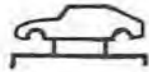

①

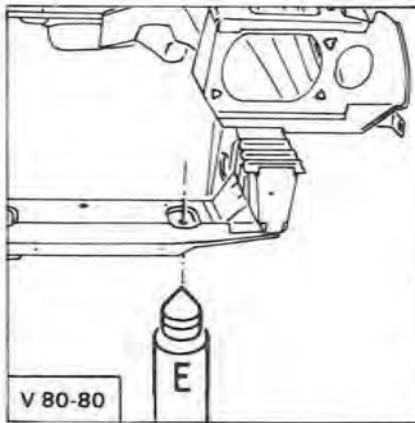

②

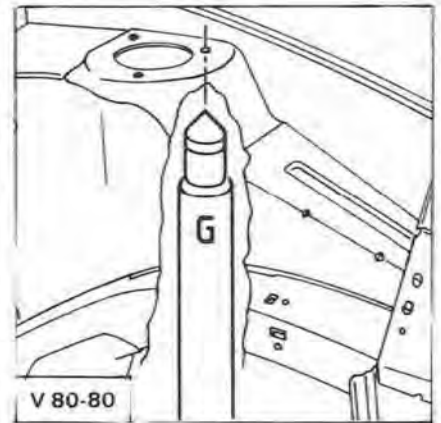

③

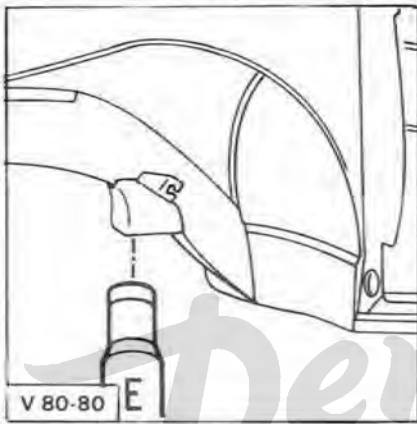

④

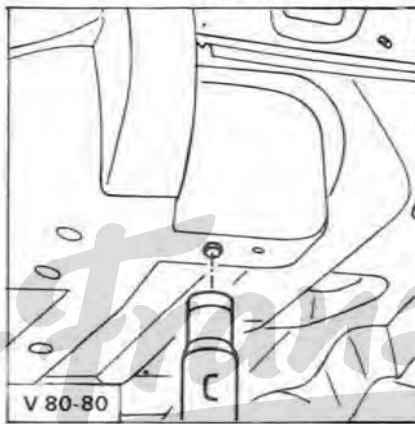

⑤

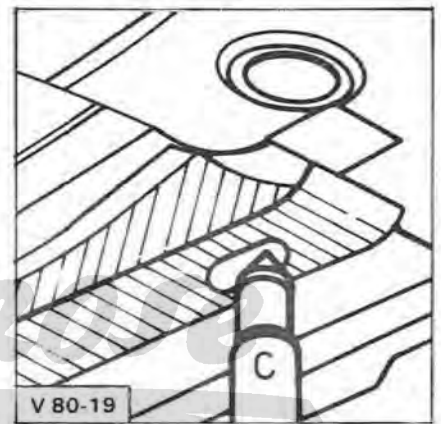

⑥

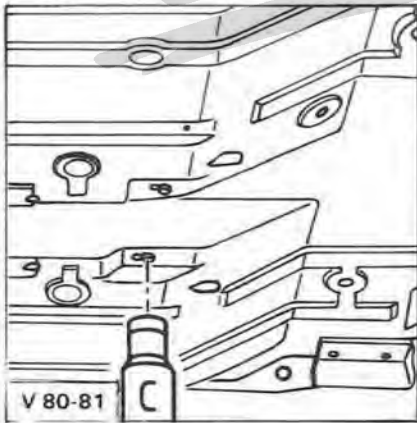

⑦

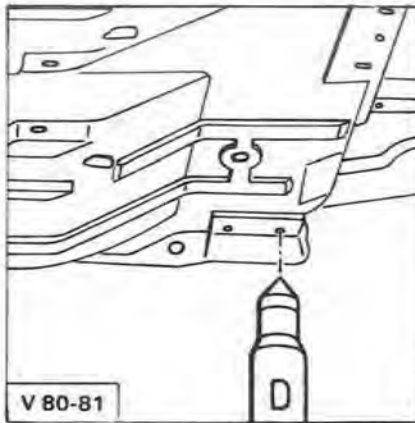

⑧

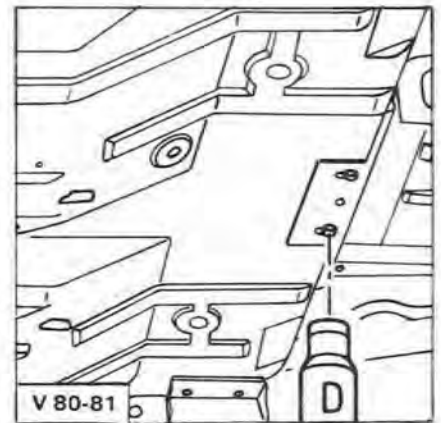

⑨

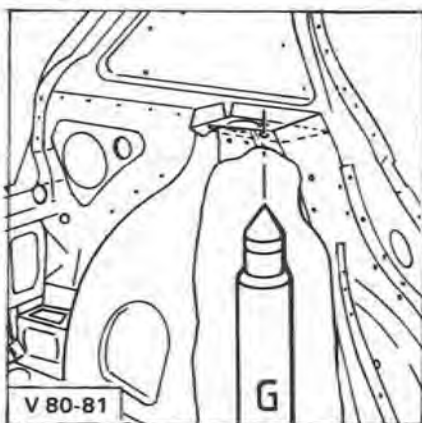

⑩

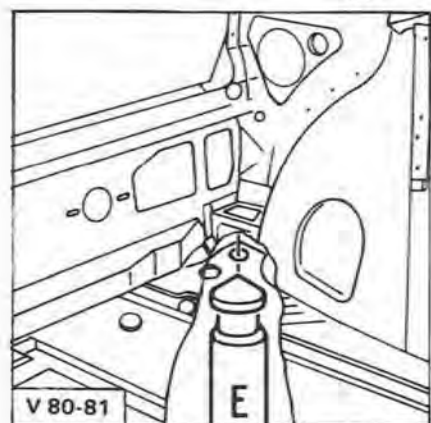

⑪

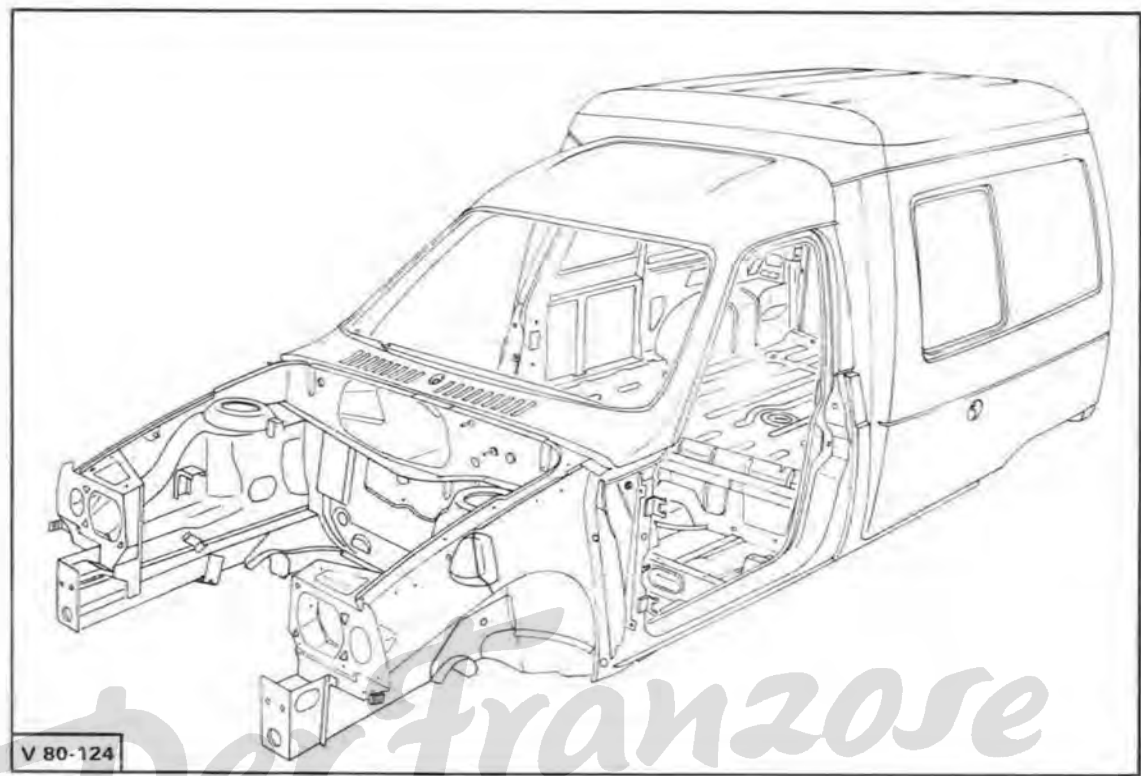
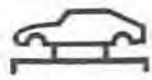

V 80-124

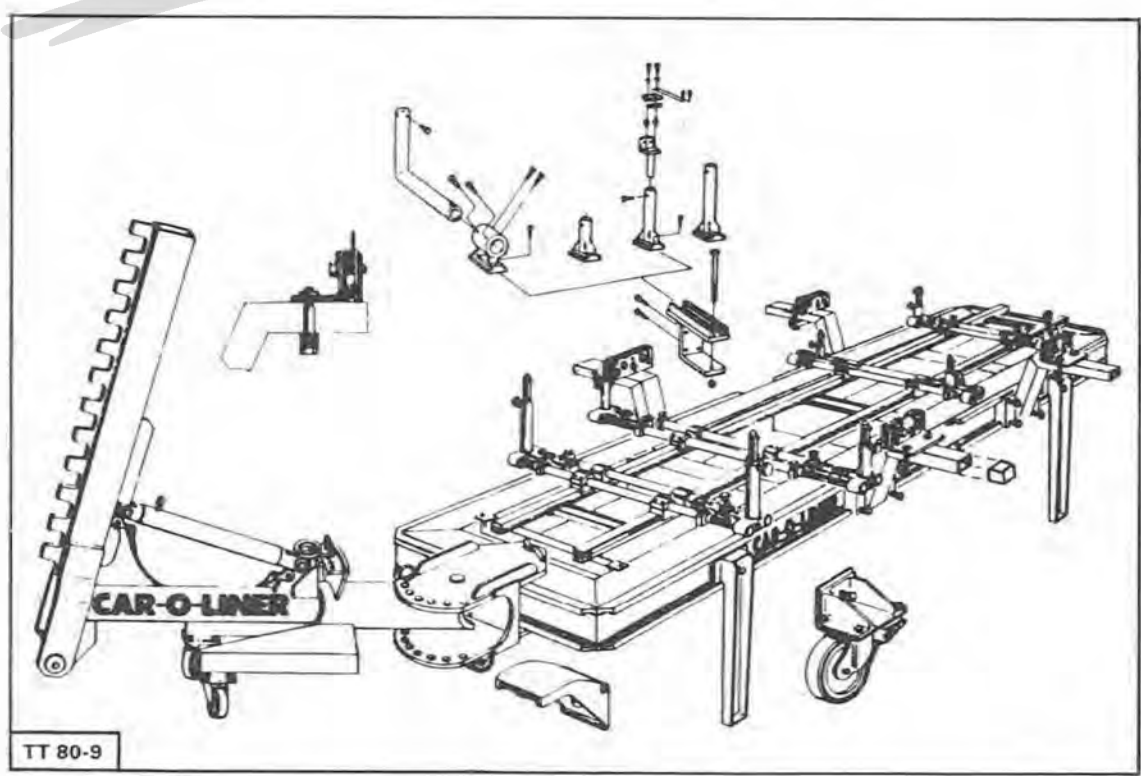

TT 80-9

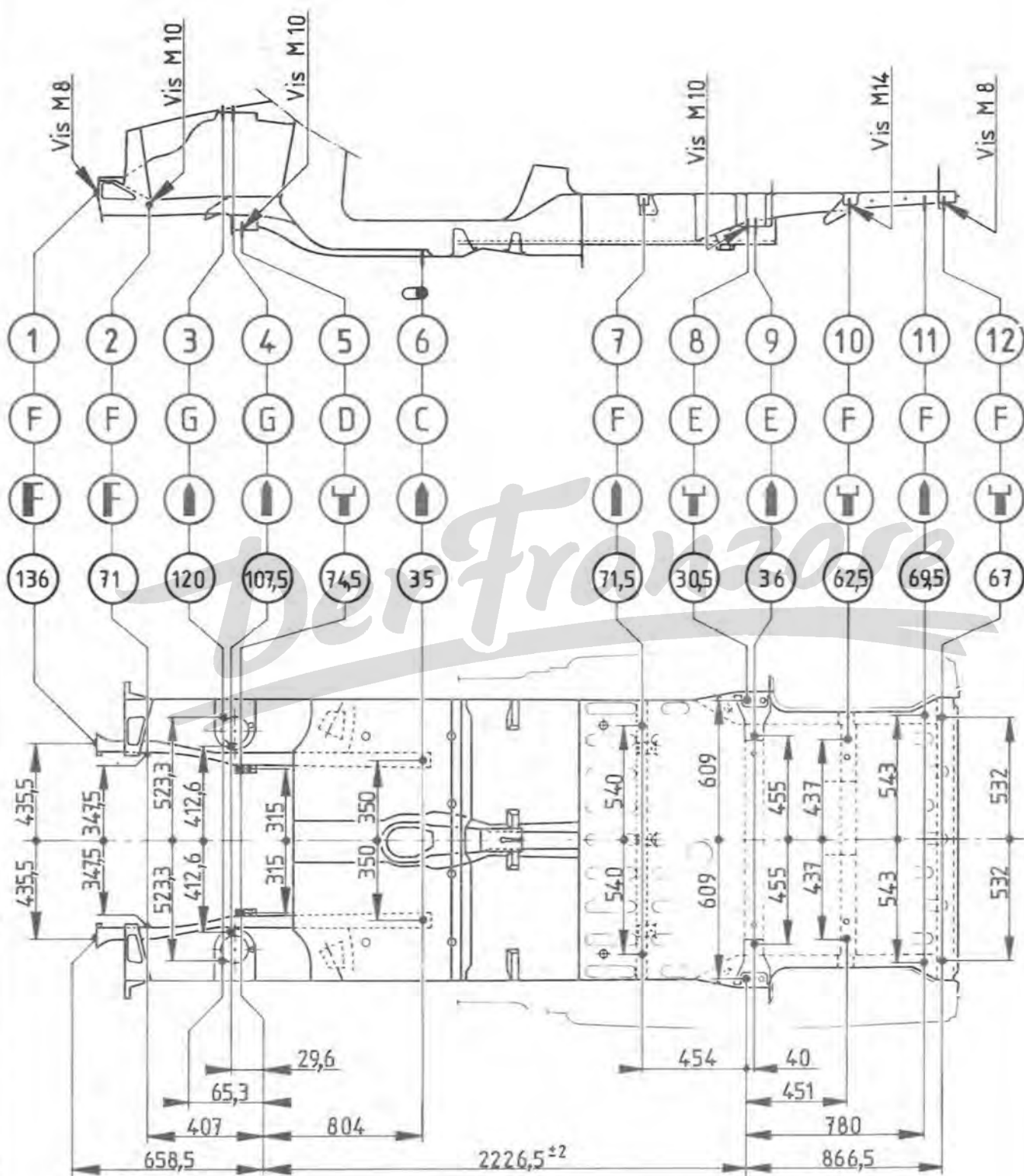

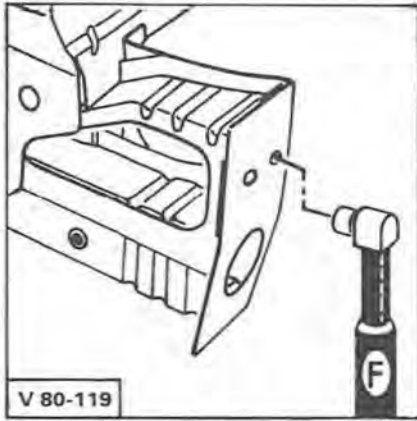

1

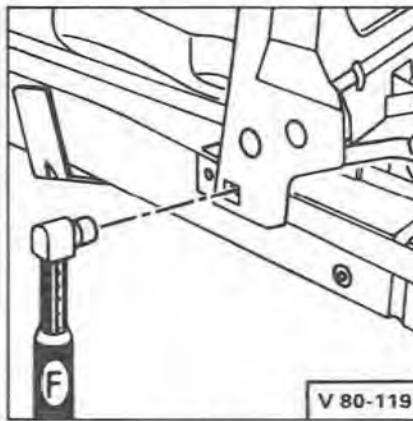

2



3

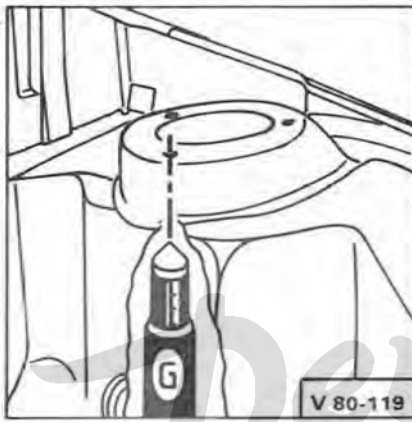

4

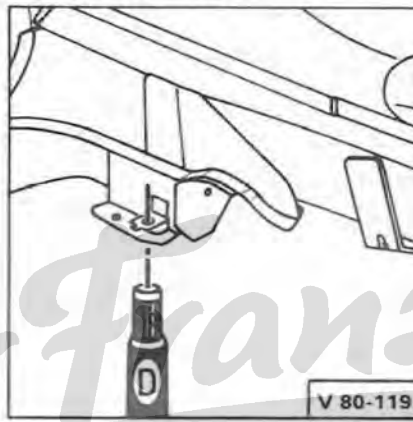

5

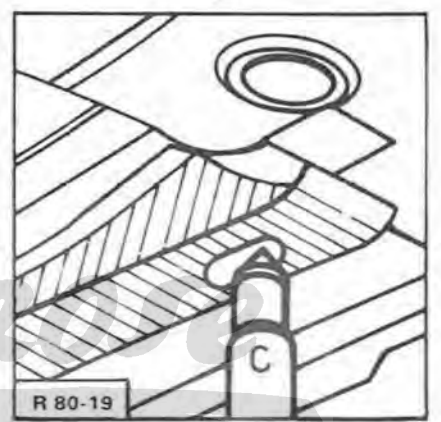

6

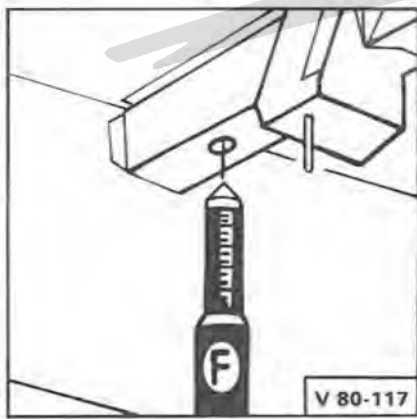

7

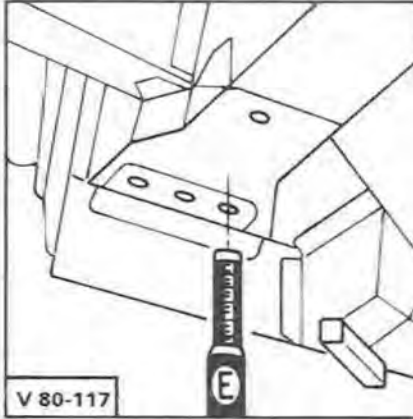

8

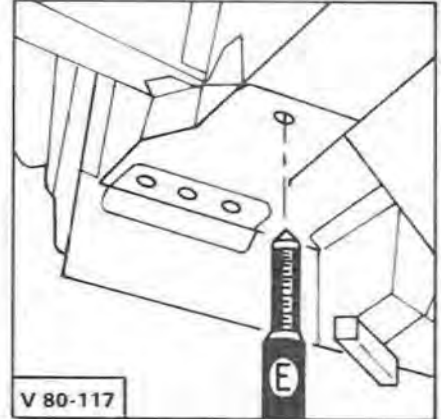

9

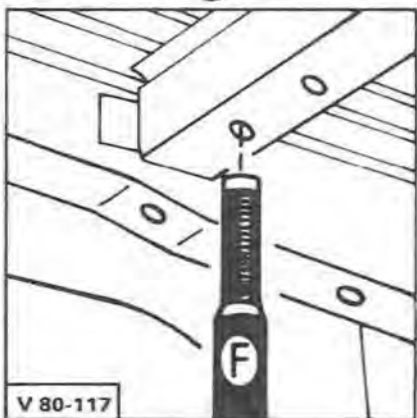

10

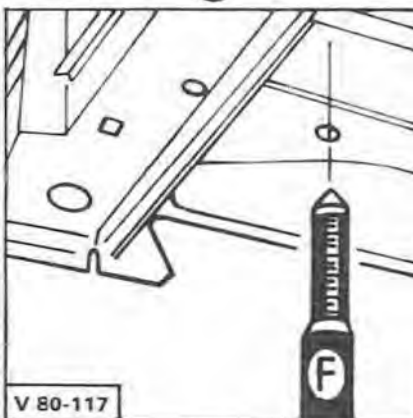

11

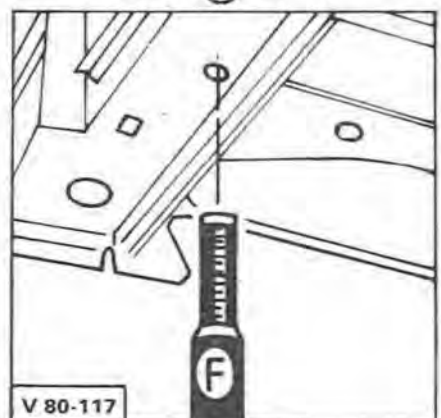

12

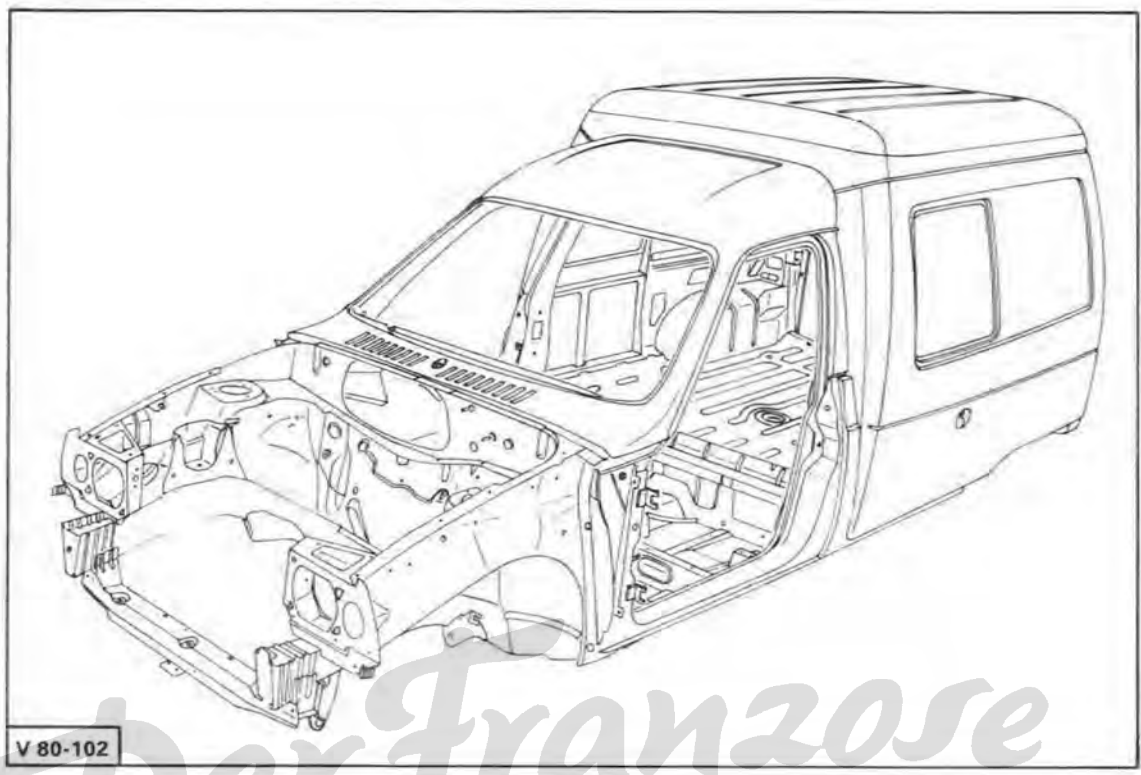

V 80-102

Der Franzose

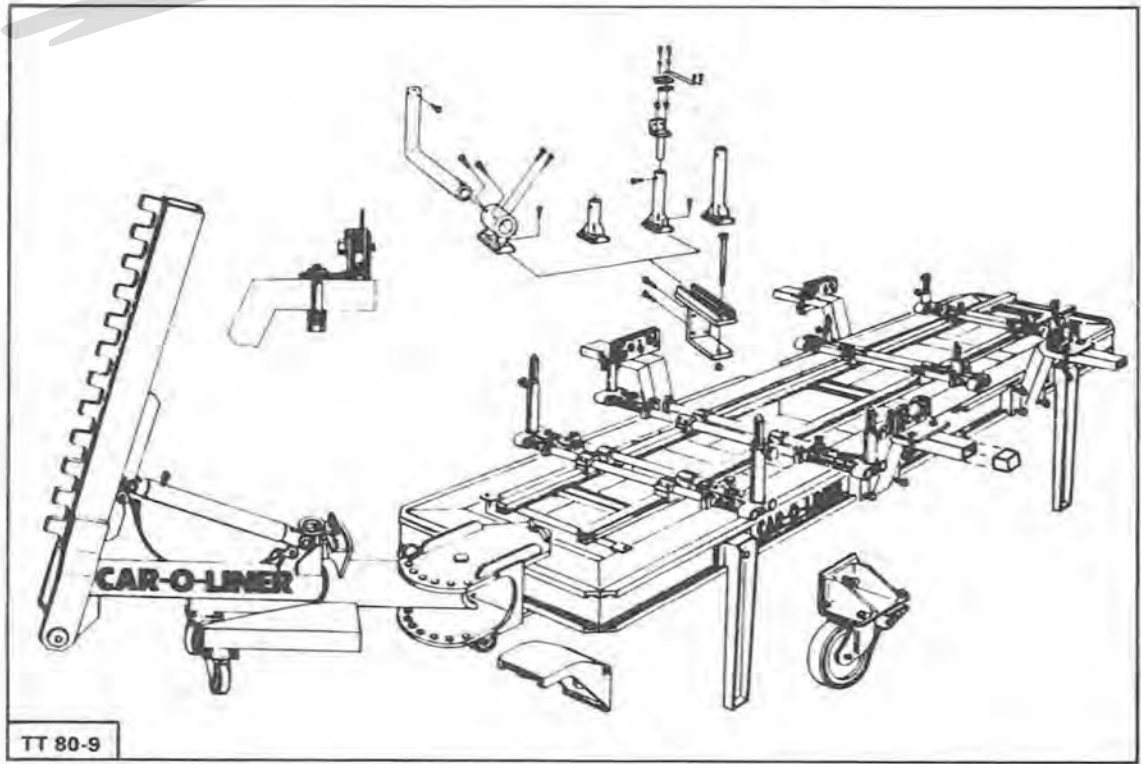

TT 80-9

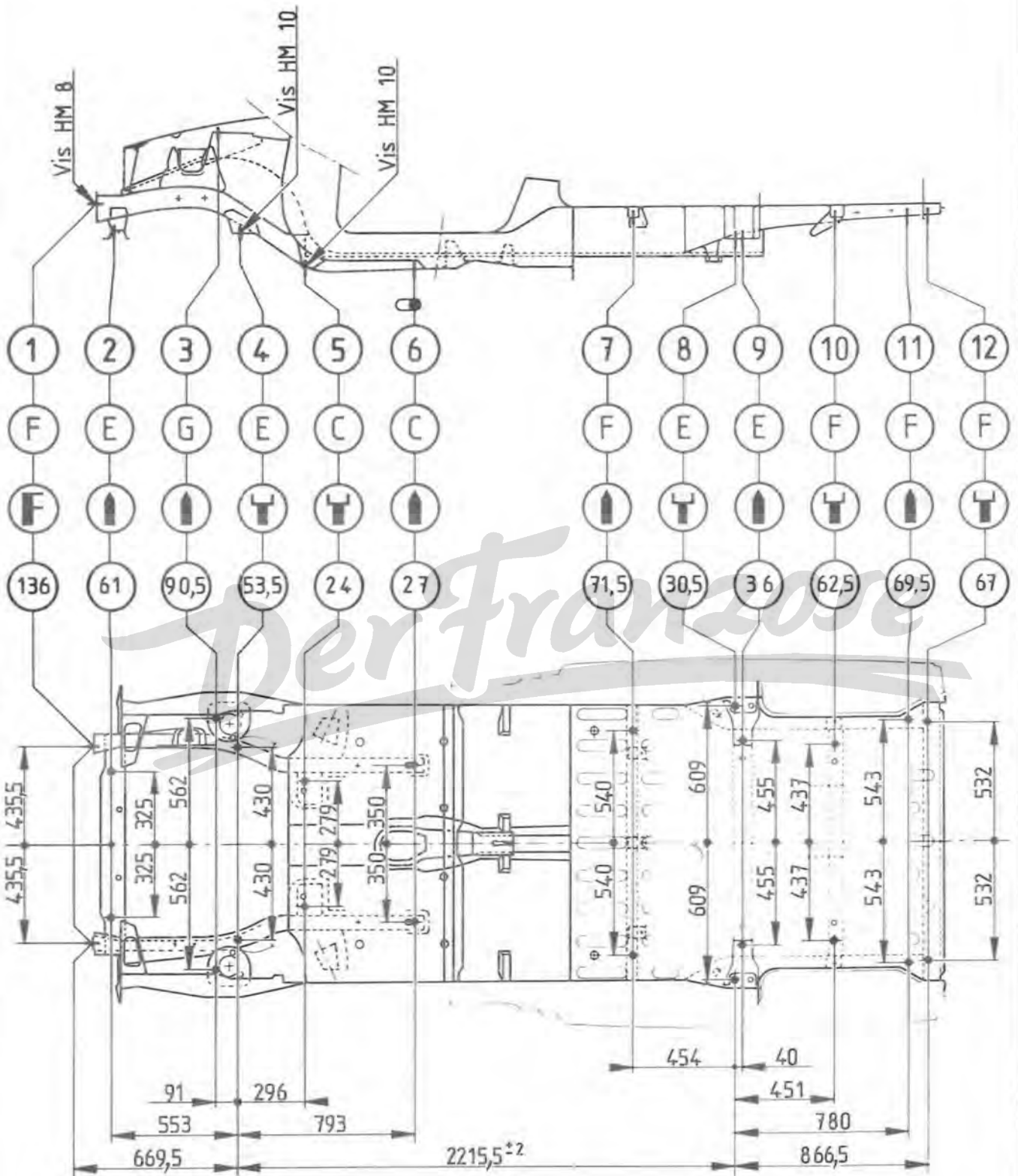

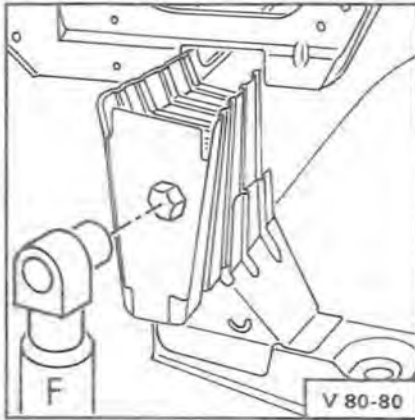

1

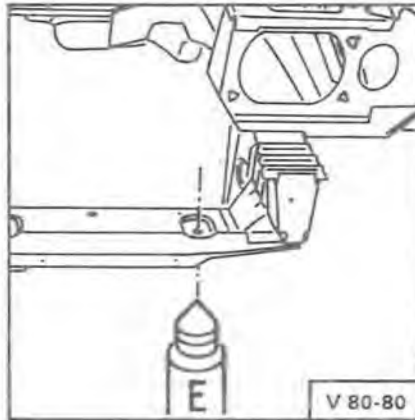

2

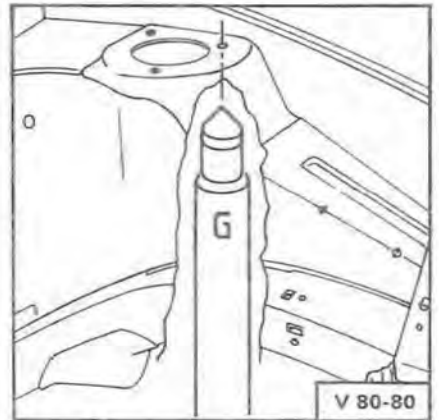

3

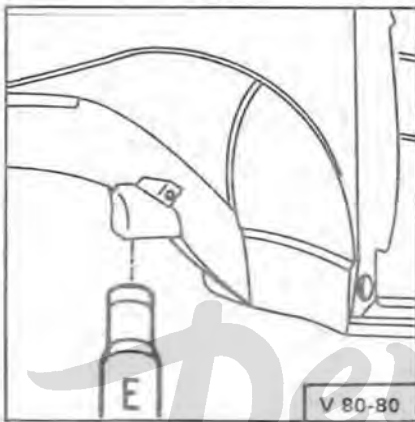

4

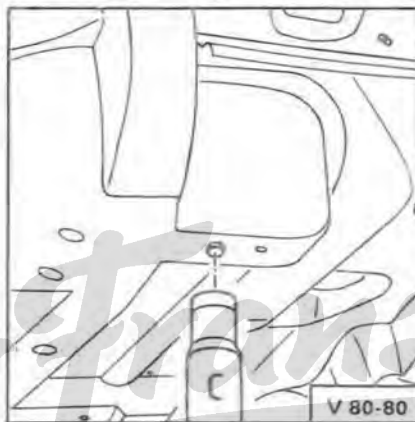

5

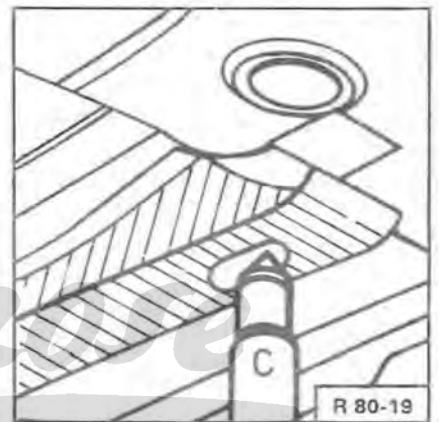

6

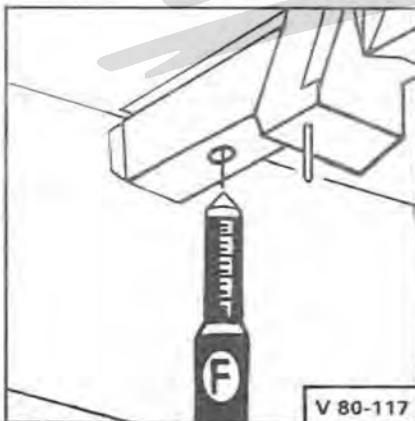

7

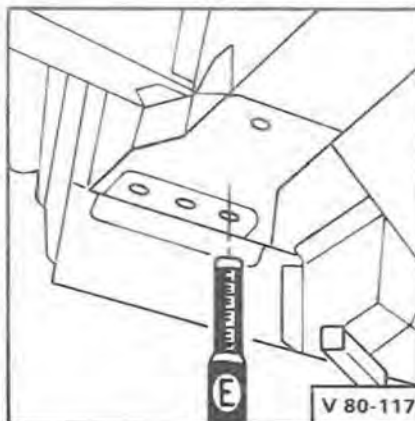

8

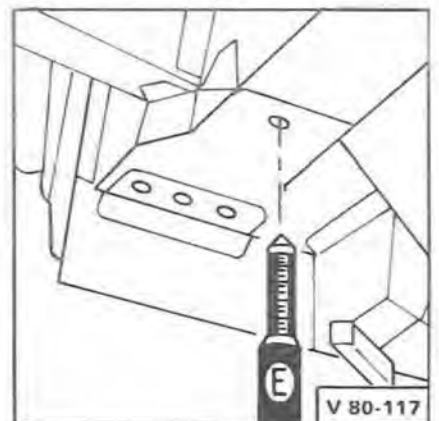

9

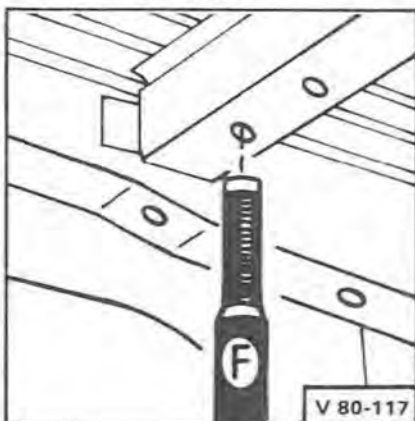

10

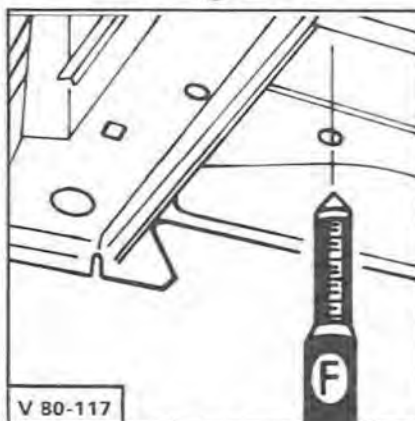

11

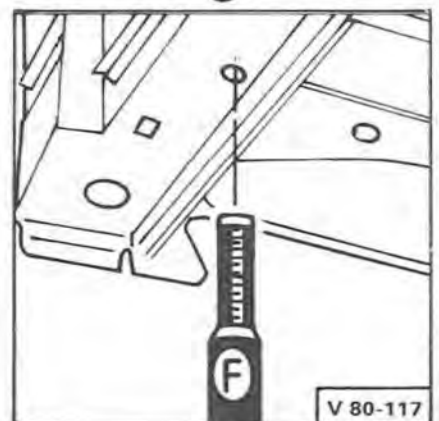

12

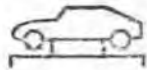

V 80-73

Der Franzose

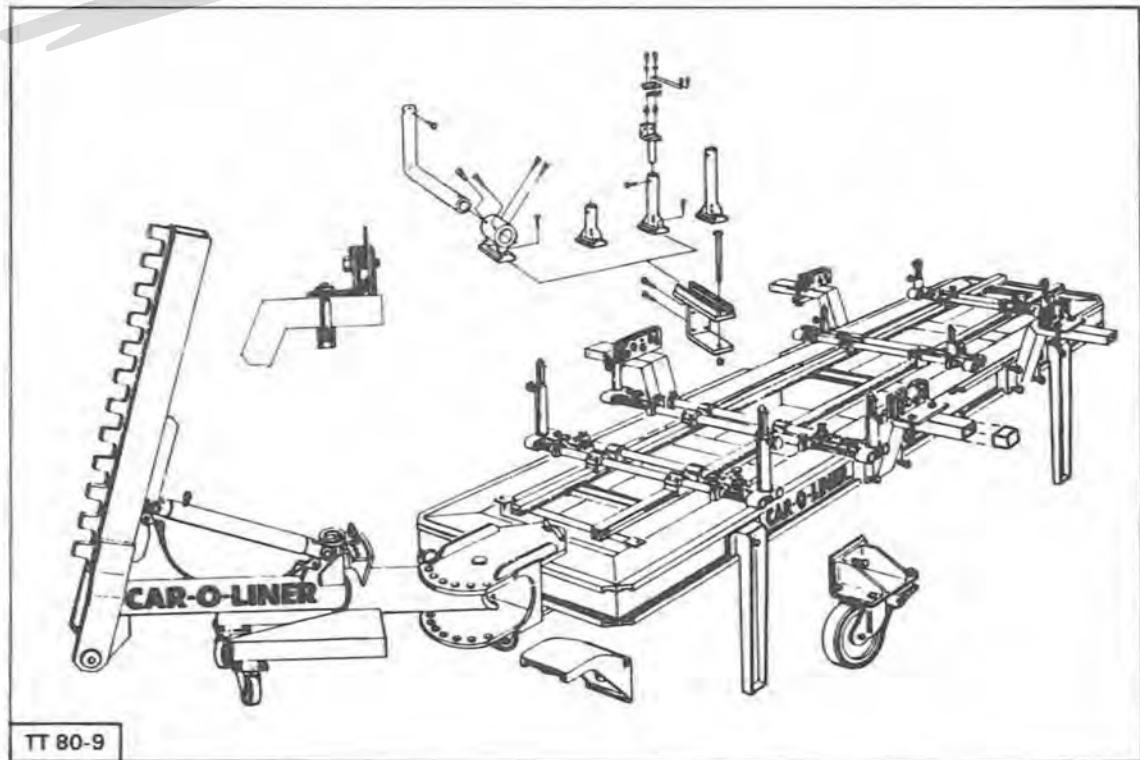

TT 80-9

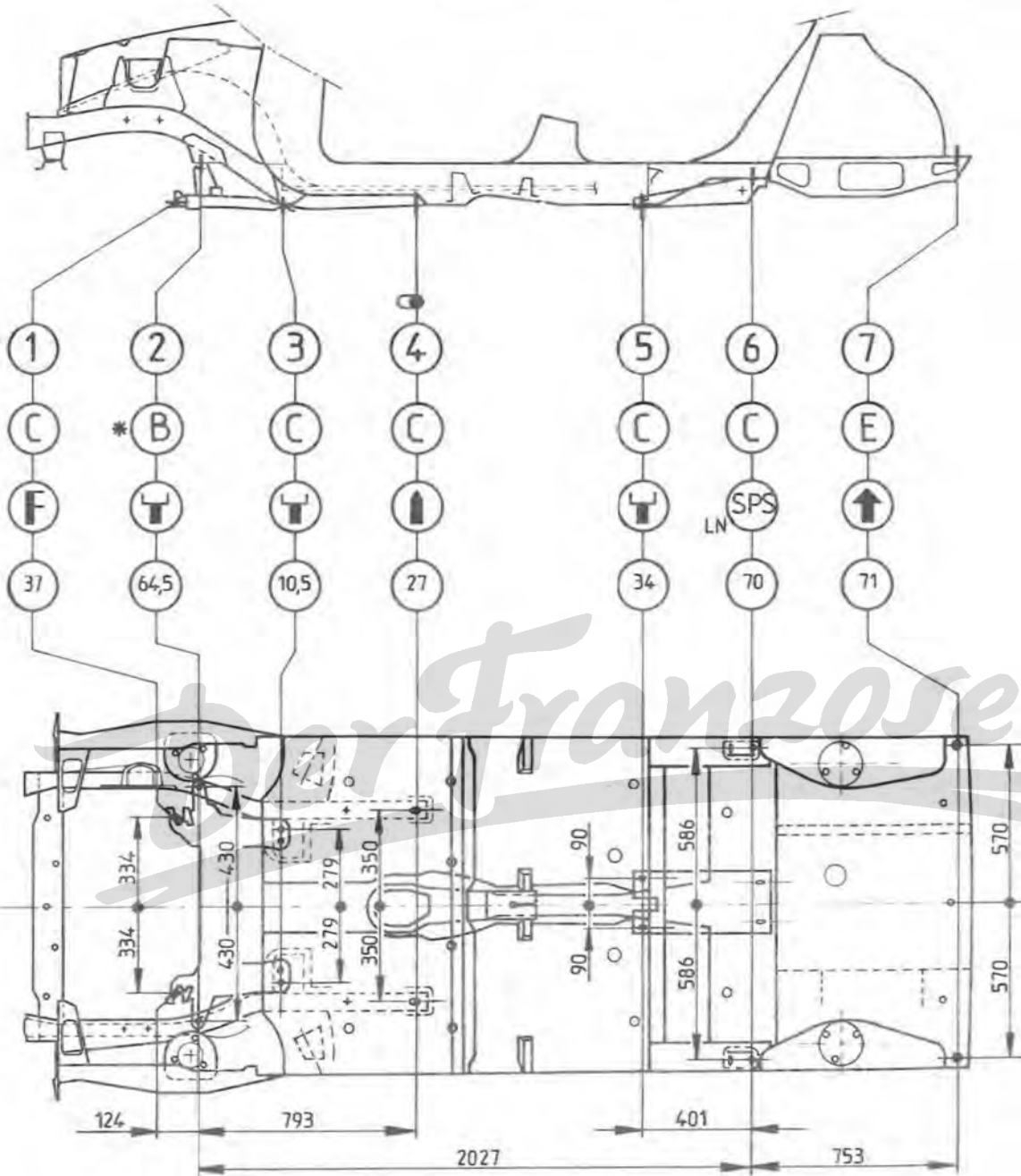
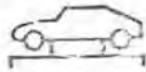

* M 217 L=120

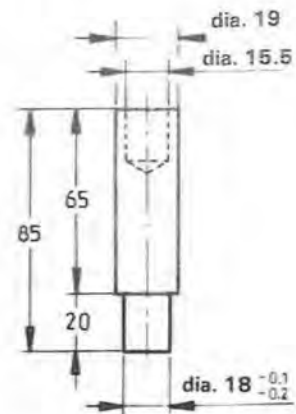

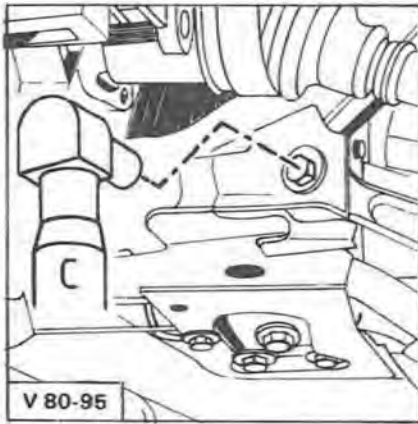
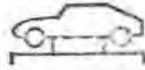

①

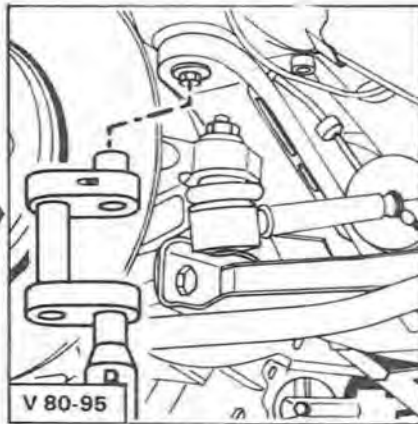

②

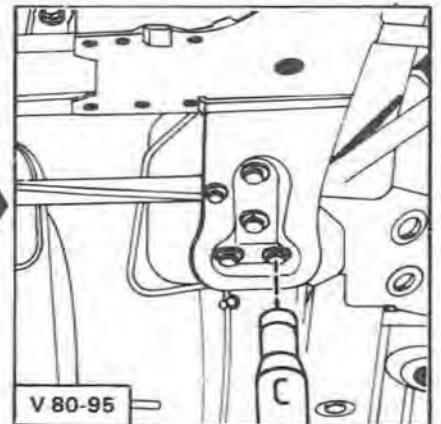

③

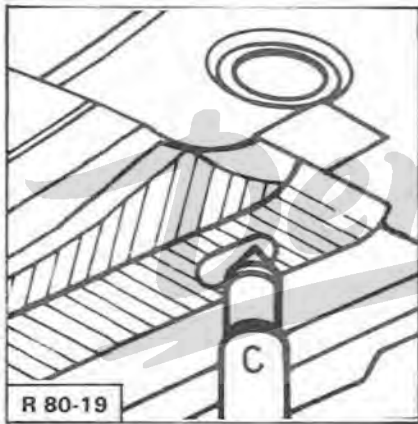

④

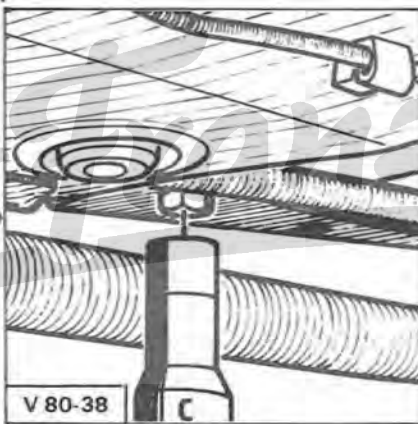

⑤

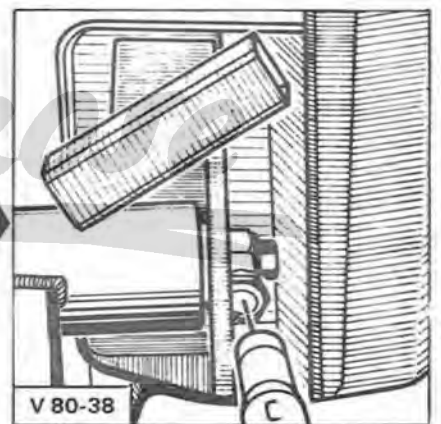

⑥

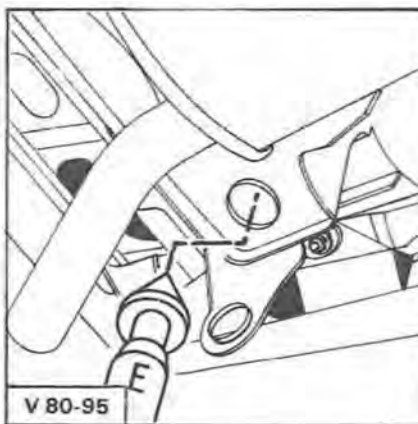

⑦



84-705

Der Franzose

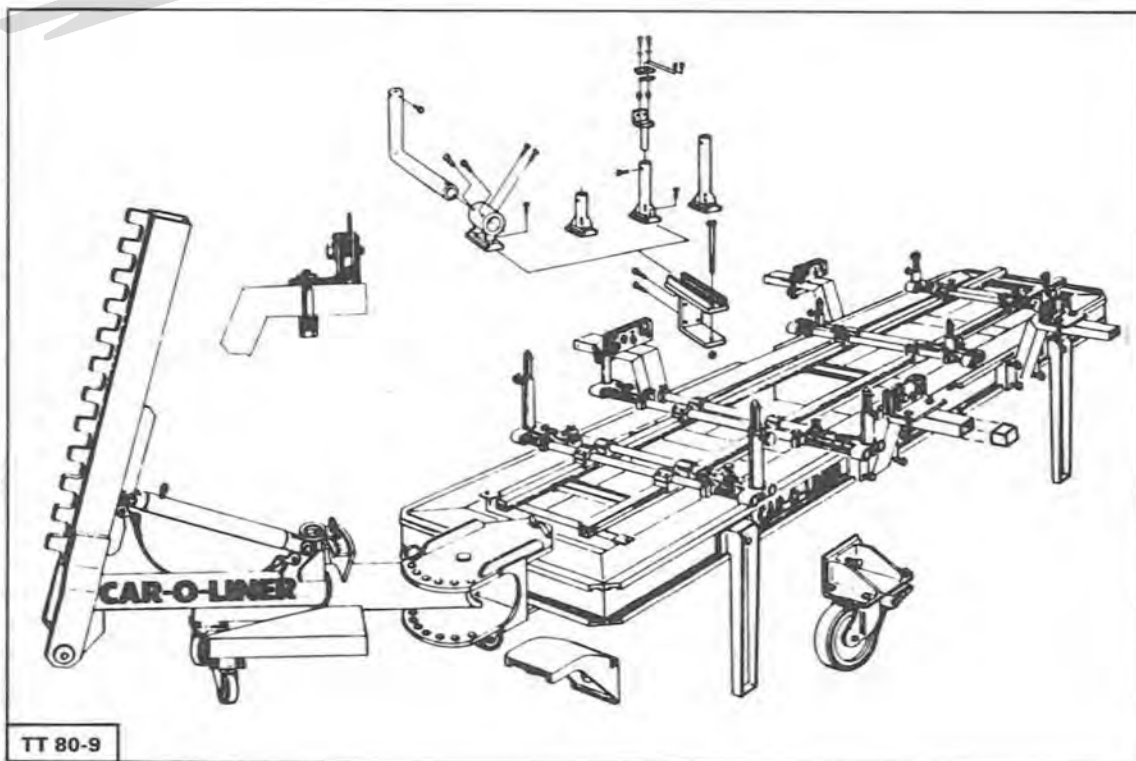

TT 80-9

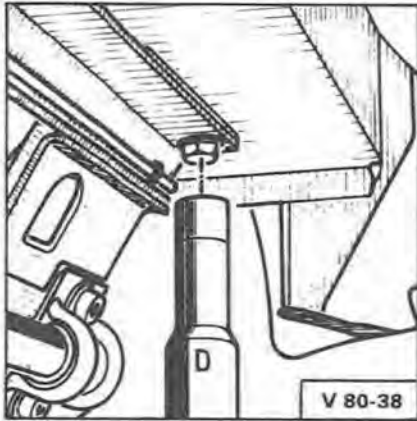

①

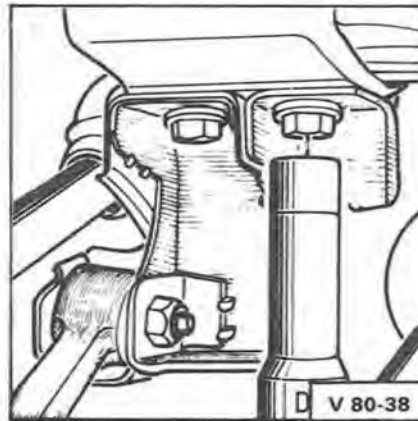

②

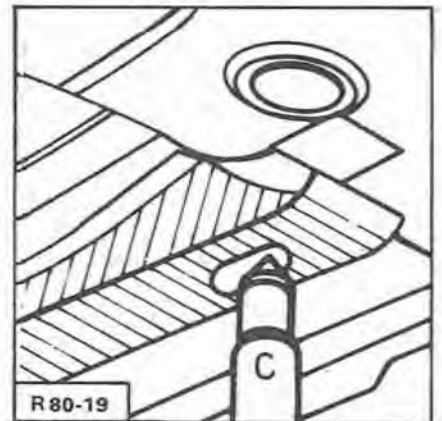

③

Der Franzose

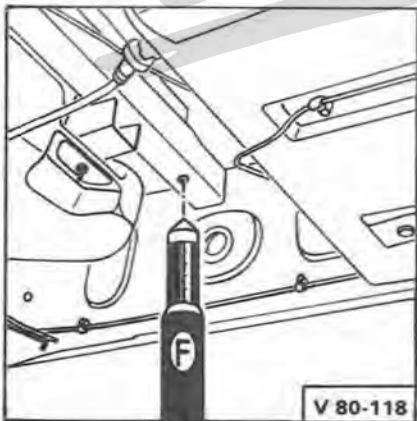

④

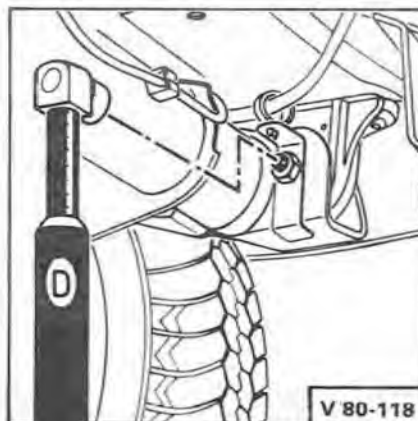

⑤

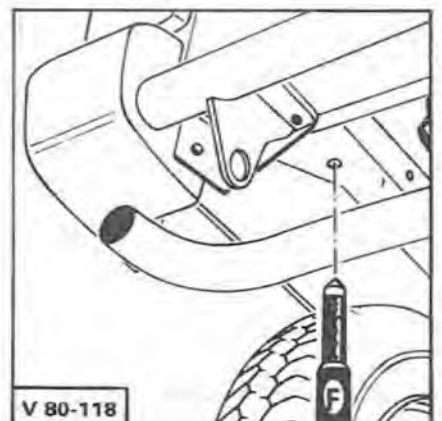

⑥



84-705

Der Franzose

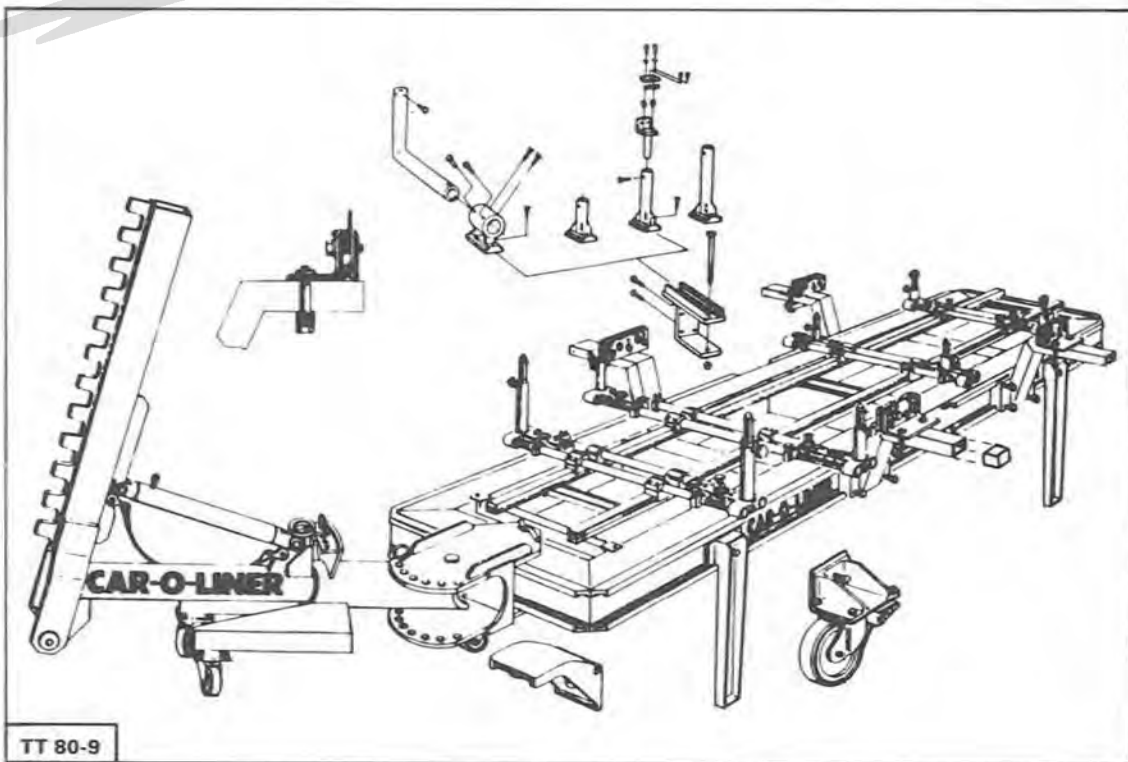

TT 80-9

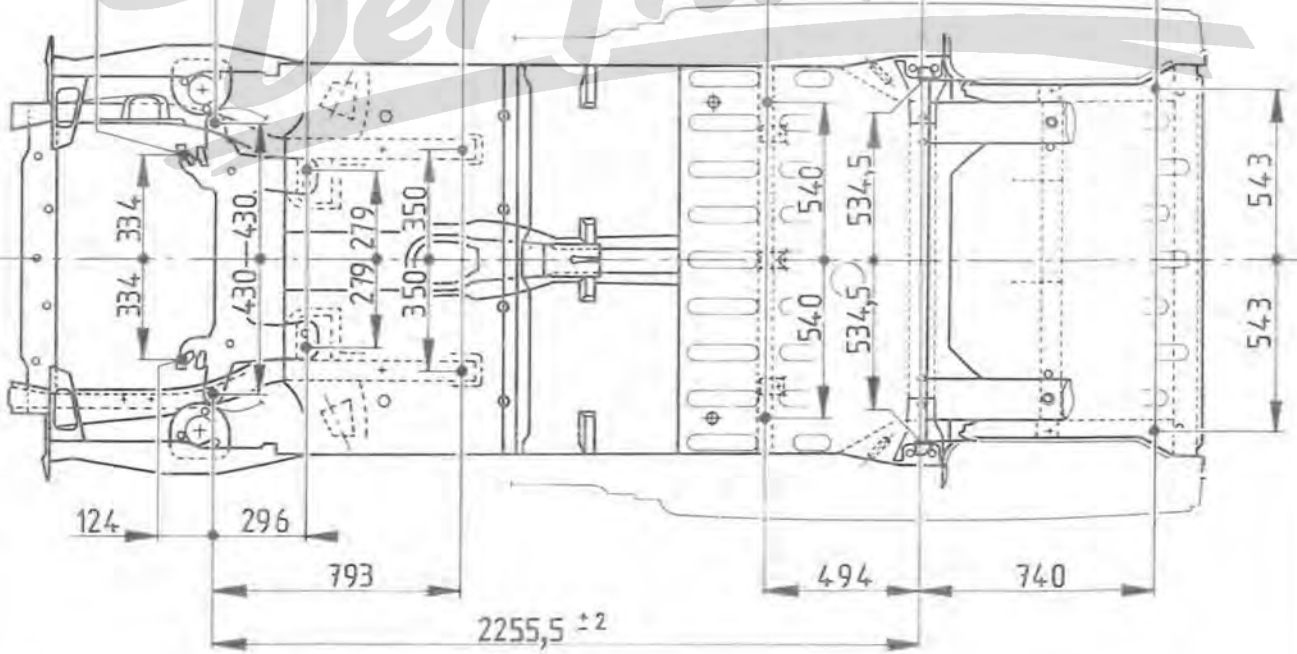
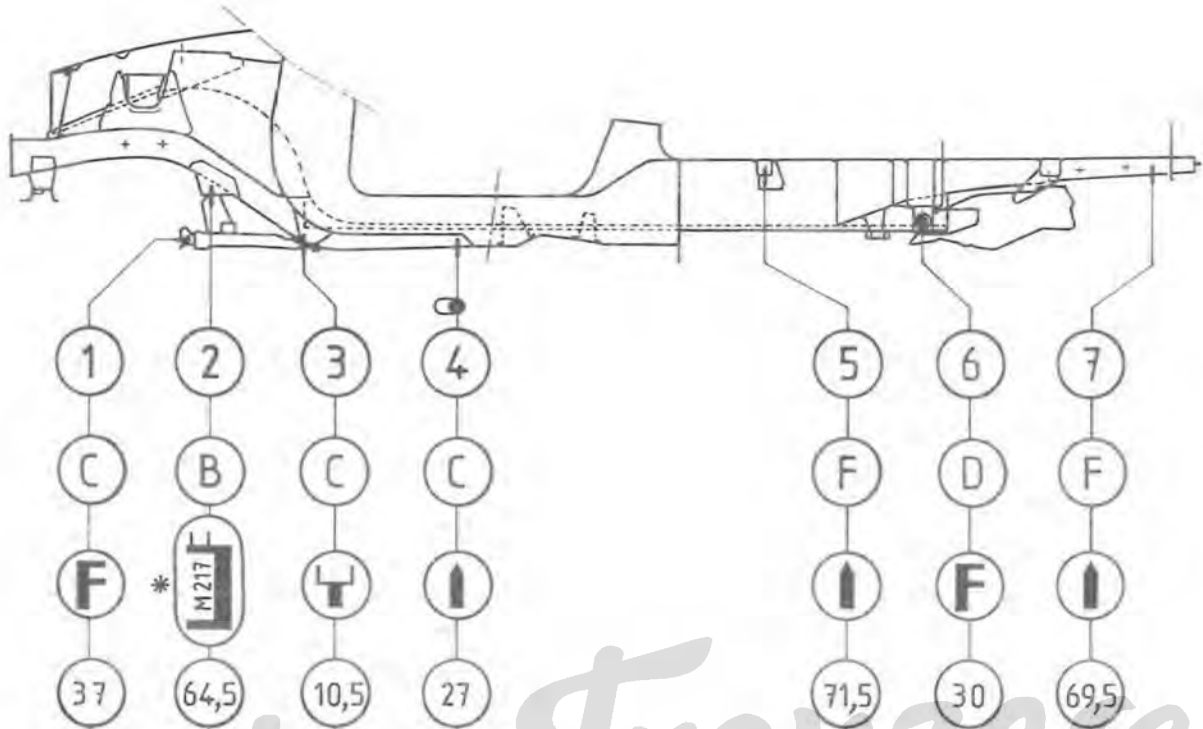
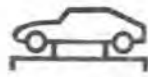

* L = 120

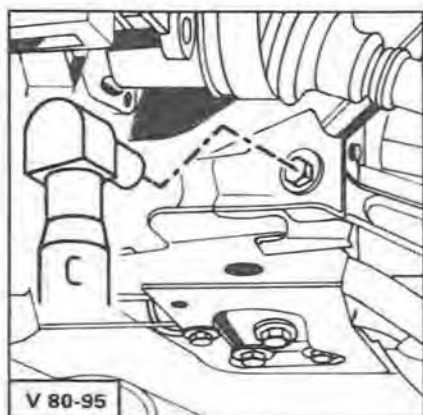

①

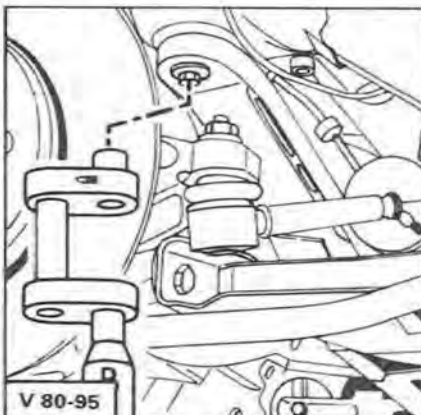

②

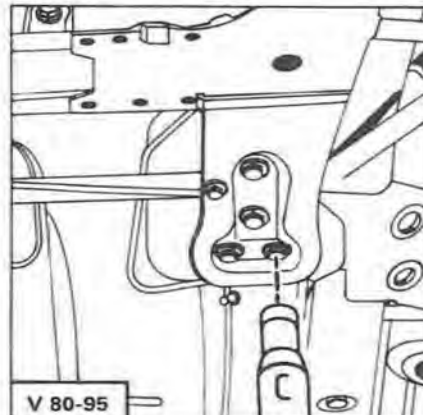

③

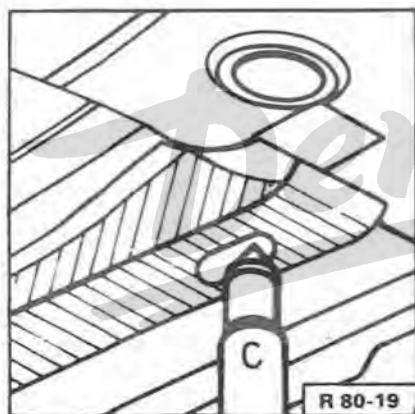

④

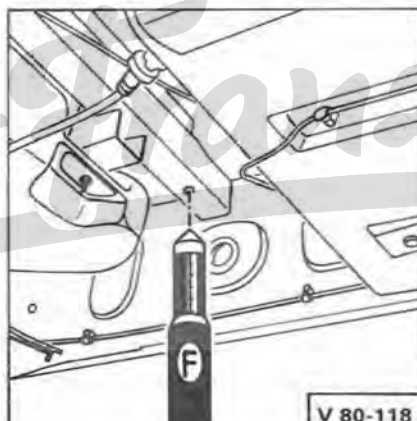

⑤

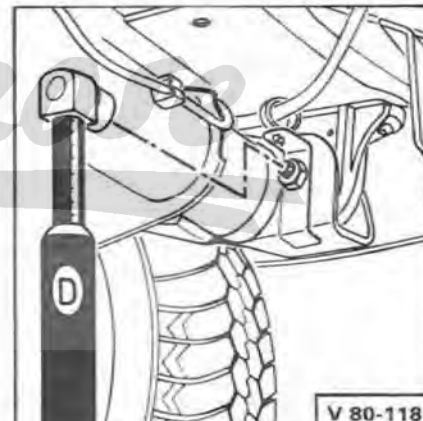

⑥

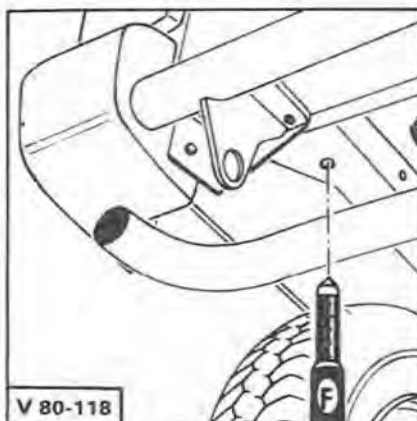

⑦

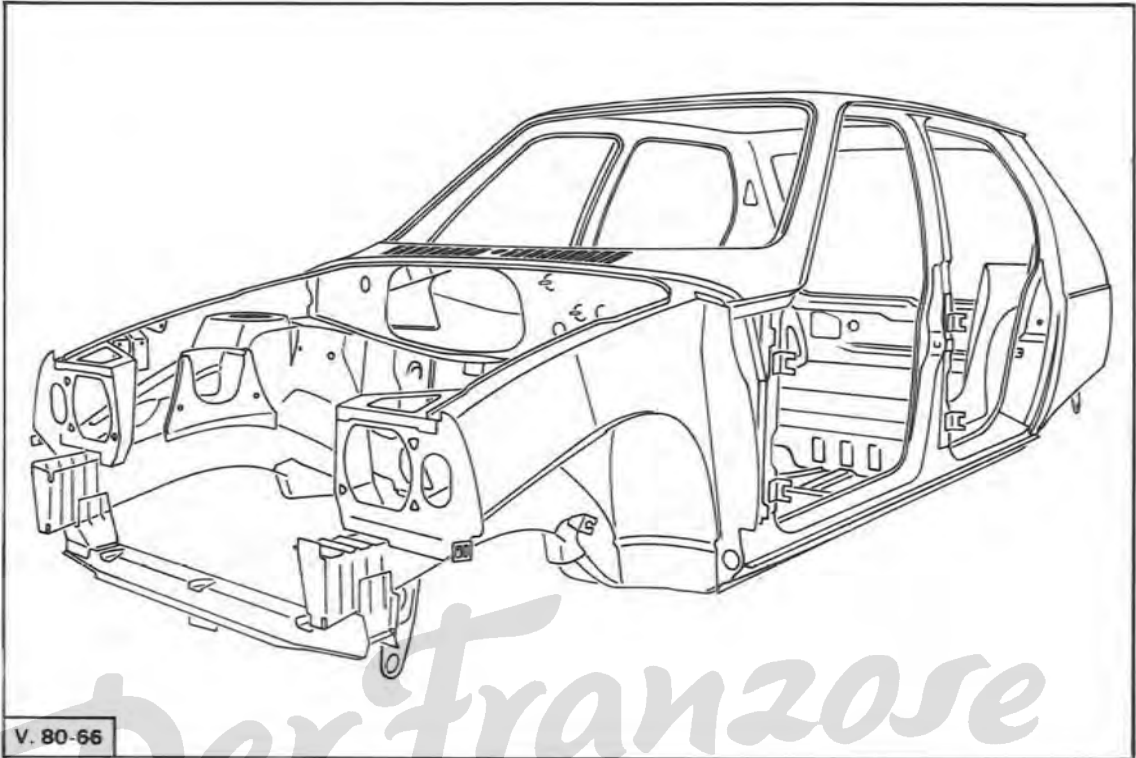

Der Franzose

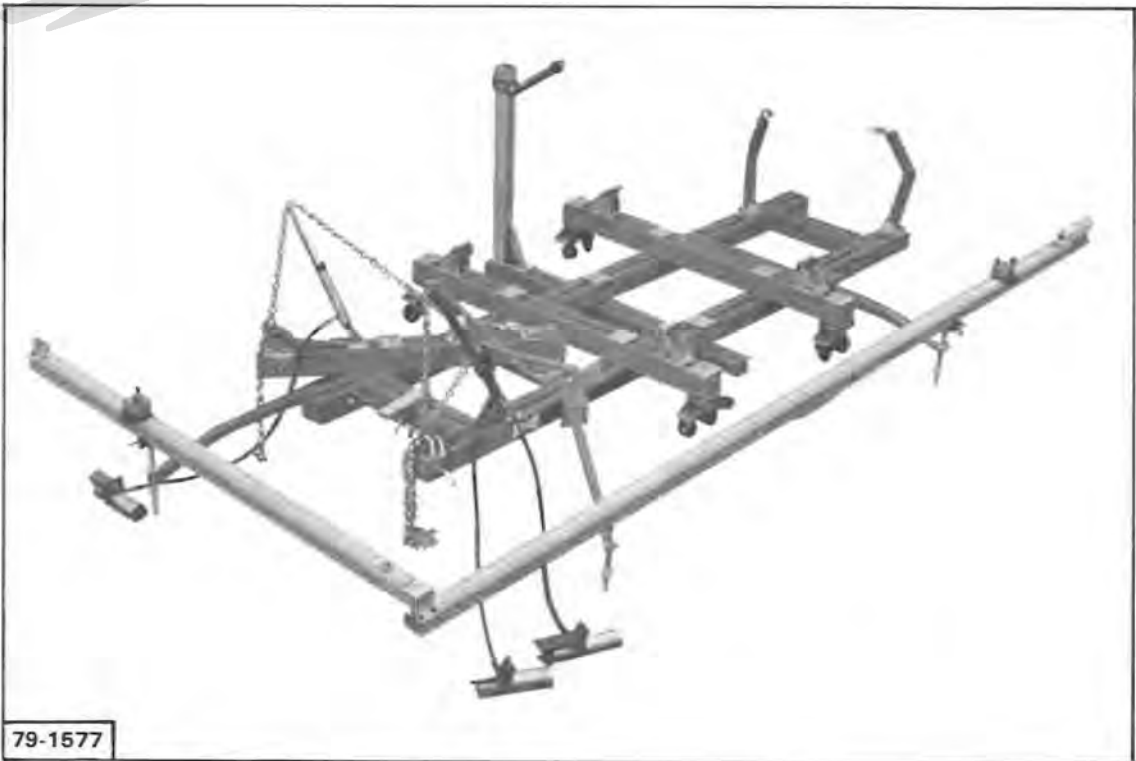

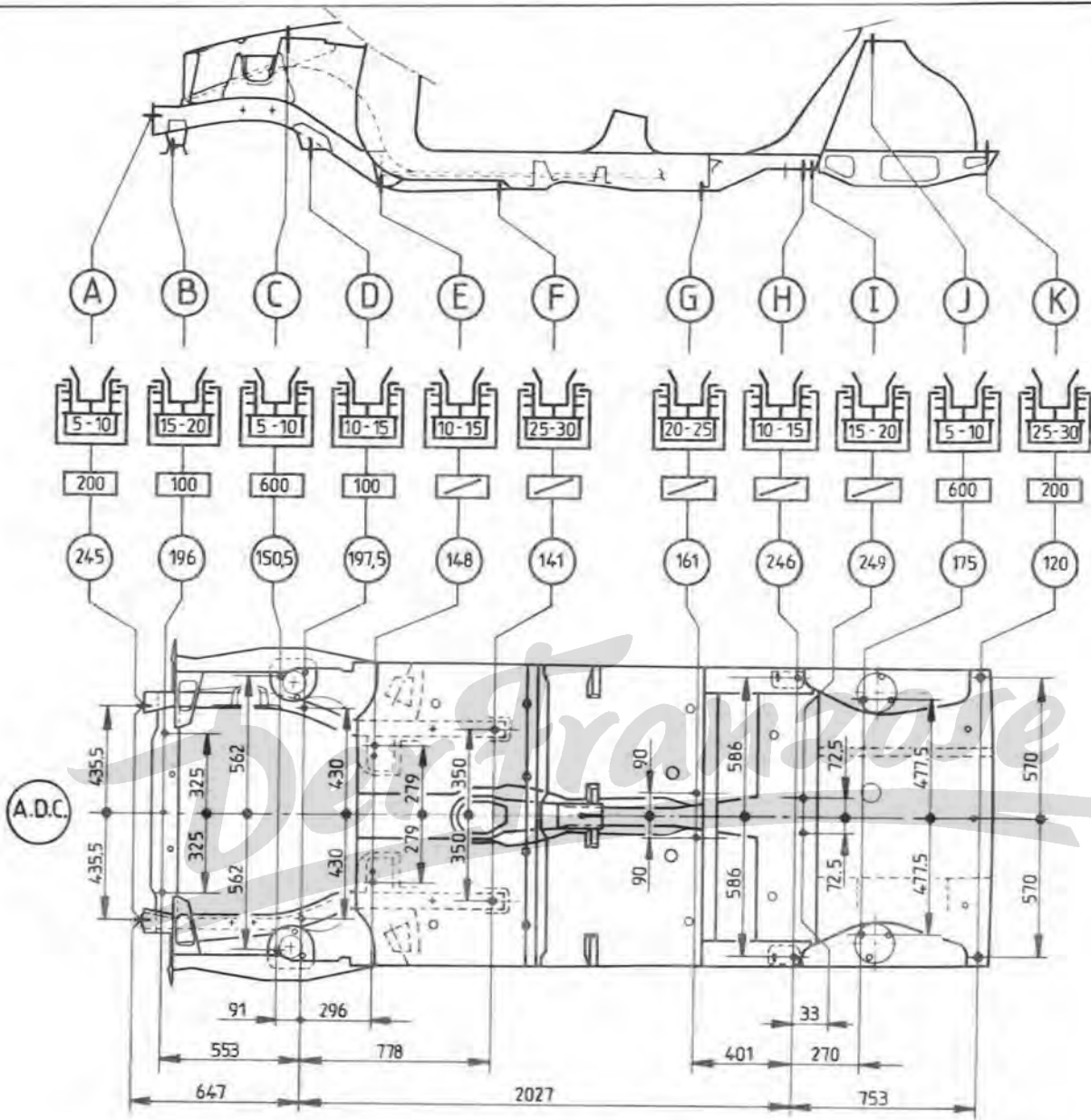
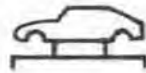

A.D.C.

Height

| Ref | Original dimensions | | |
|-----|---------------------|--|--|
| A | 245 | | |
| B | 196 | | |
| C | 150,5 | | |
| D | 197,5 | | |
| E | 148 | | |
| F | 141 | | |
| G | 161 | | |
| H | 246 | | |
| I | 249 | | |
| J | 175 | | |
| K | 120 | | |

Length

| Ref | Original dimensions | | |
|-----|---------------------|--|--|
| A-D | 647 | | |
| B-D | 553 | | |
| C-D | 91 | | |
| D | 0 | | |
| E-D | 296 | | |
| F-D | 778 | | |
| G-H | 401 | | |
| H-D | 2027 | | |
| I-H | 33 | | |
| J-H | 270 | | |
| K-H | 753 | | |

Width - Bodyshe'll axis

| Ref | Original dimensions | | |
|-----|---------------------|--|--|
| A | 435,5 | | |
| B | 325 | | |
| C | 562 | | |
| D | 430 | | |
| E | 279 | | |
| F | 350 | | |
| G | 90 | | |
| H | 586 | | |
| I | 72,5 | | |
| J | 477,5 | | |
| K | 570 | | |

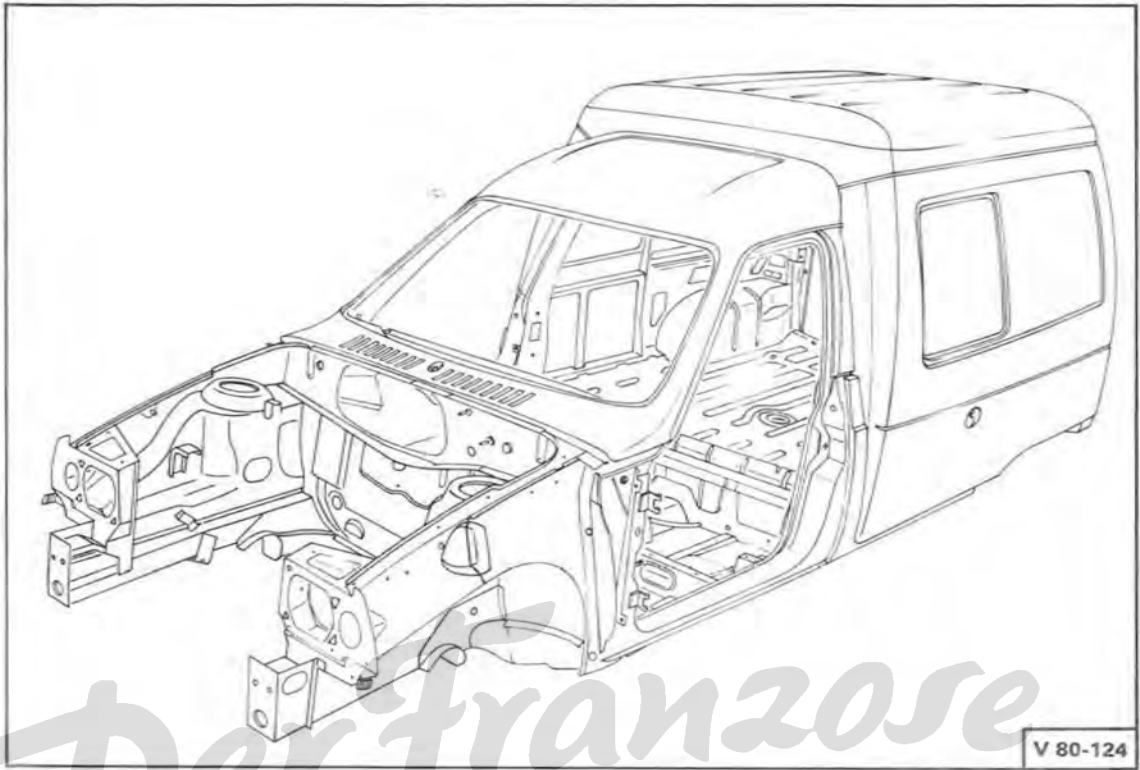

V 80-124

Derfranzose

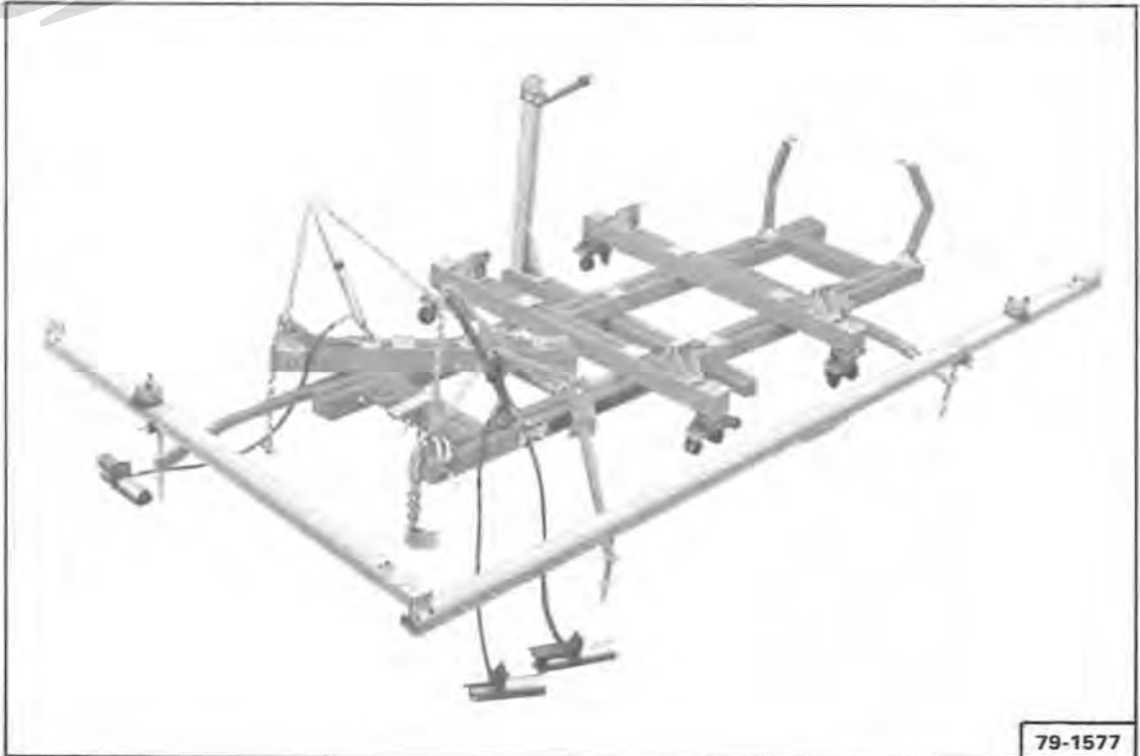

79-1577

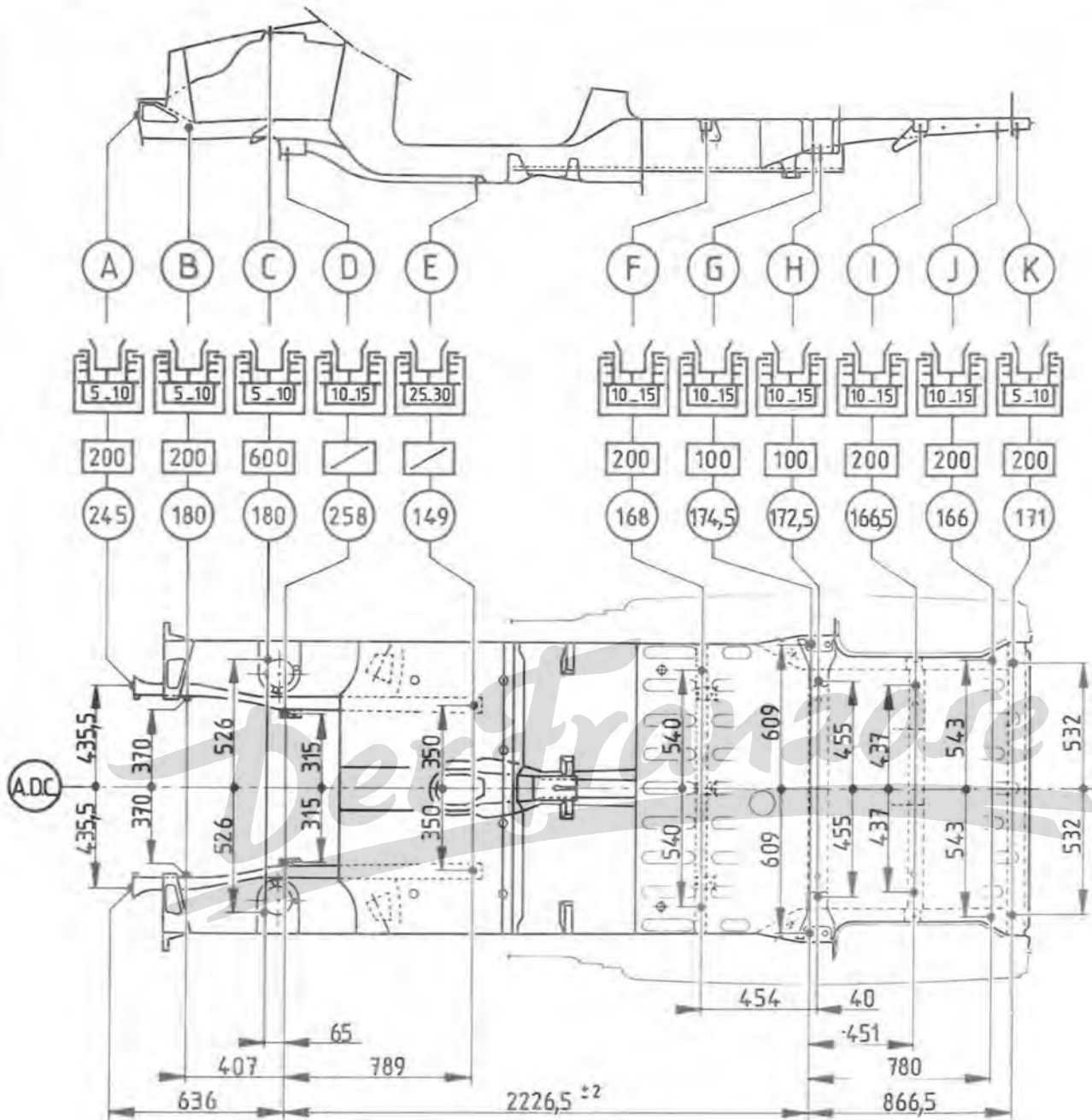

Hauteur

| Réf. | Nominal | Déviaton Gauche | Déviaton Droite |
|------|---------|--------------------|--------------------|
| A | 245 | | |
| B | 180 | | |
| C | 180 | | |
| D | 258 | | |
| E | 149 | | |
| F | 168 | | |
| G | 174,5 | | |
| H | 172,5 | | |
| I | 166,5 | | |
| J | 166 | | |
| K | 171 | | |

Longueur

| Réf. | Nominal | Déviaton Gauche | Déviaton Droite |
|------|---------|--------------------|--------------------|
| A..D | 636 | | |
| B..D | 407 | | |
| C..D | 65 | | |
| D | 0 | | |
| E..D | 789 | | |
| F..G | 454 | | |
| G..D | 2226,5 | | |
| H..G | 40 | | |
| I..G | 451 | | |
| J..G | 780 | | |
| K..G | 866,5 | | |

Largeur / ADC

| Réf. | Nominal | Déviaton Gauche | Déviaton Droite |
|------|---------|--------------------|--------------------|
| A | 435,5 | | |
| B | 370 | | |
| C | 526 | | |
| D | 315 | | |
| E | 350 | | |
| F | 540 | | |
| G | 609 | | |
| H | 455 | | |
| I | 437 | | |
| J | 543 | | |
| K | 532 | | |



Der Franzose

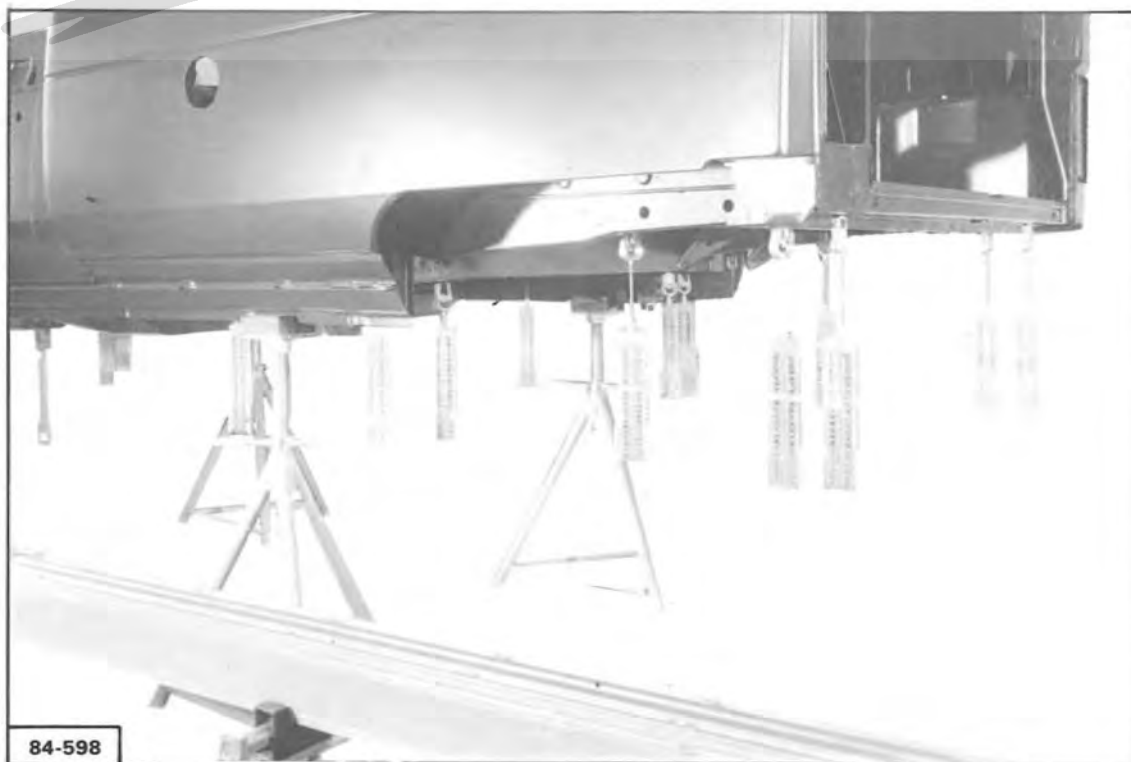

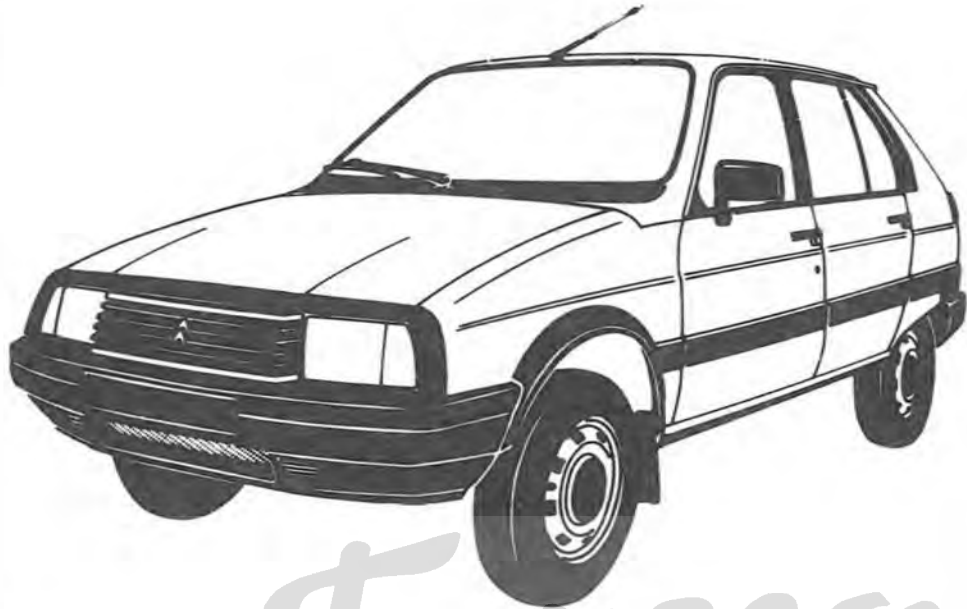
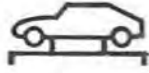

V 80-73

Der Franzose

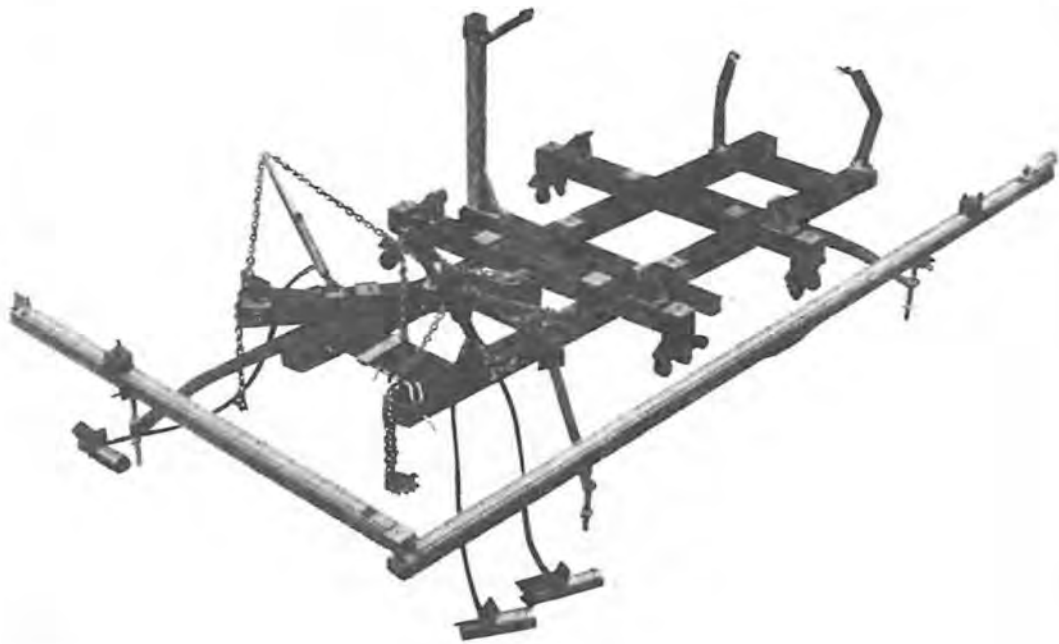

79-1577

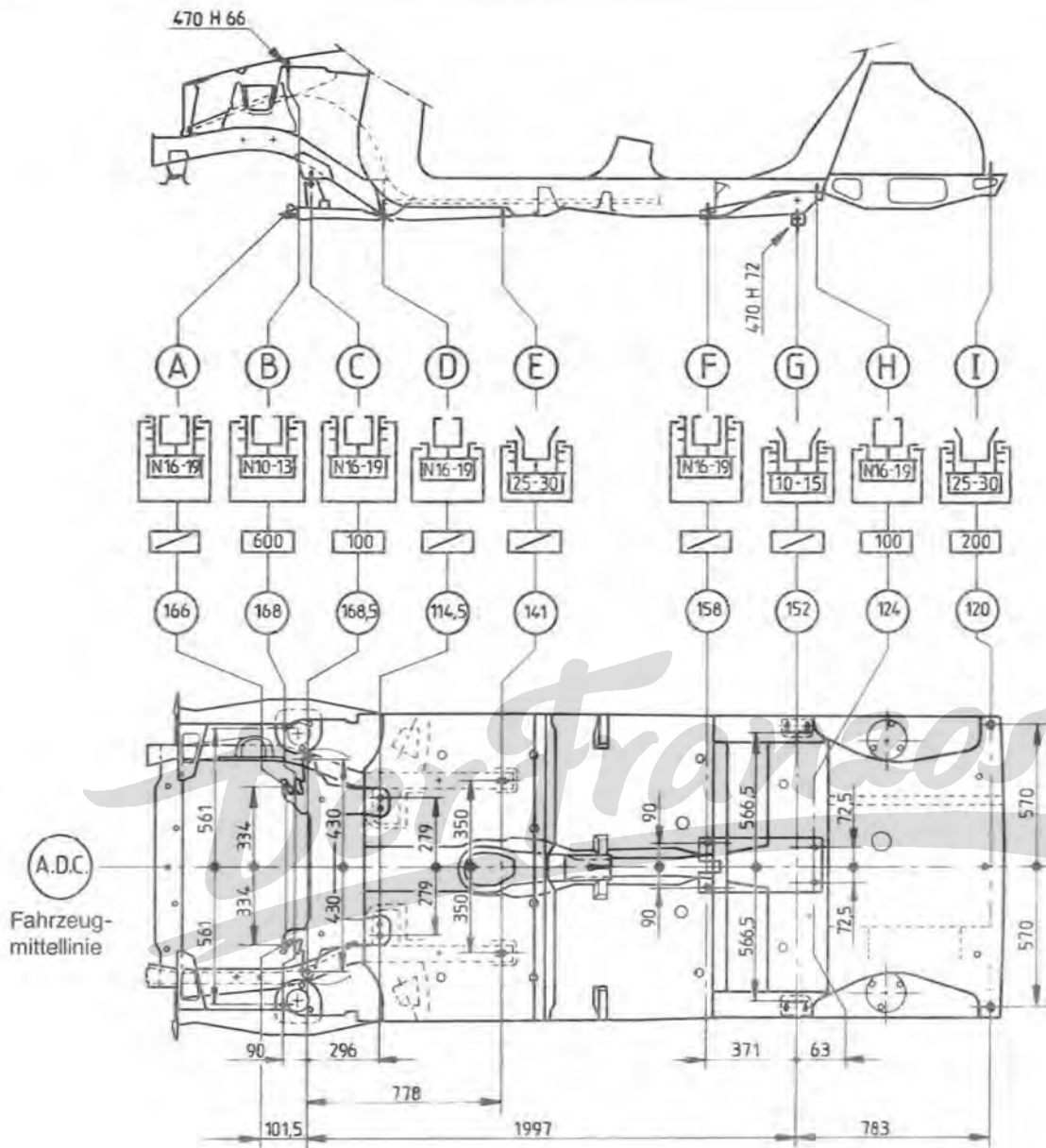
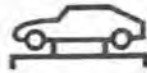

Höhe

| | Sollwert | Abweichung links | rechts |
|---|----------|------------------|--------|
| A | 166 | | |
| B | 168 | | |
| C | 168,5 | | |
| D | 114,5 | | |
| E | 141 | | |
| F | 158 | | |
| G | 152 | | |
| H | 124 | | |
| I | 120 | | |

Länge

| | Sollwert | Abweichung links | rechts |
|-----|----------|------------------|--------|
| A-C | 101,5 | | |
| B-C | 90 | | |
| C | 0 | | |
| D-C | 296 | | |
| E-C | 778 | | |
| F-G | 371 | | |
| G-C | 1997 | | |
| H-G | 63 | | |
| I-G | 783 | | |

Breite/A.D.C.

| | Sollwert | Abweichung links | rechts |
|---|----------|------------------|--------|
| A | 334 | | |
| B | 561 | | |
| C | 430 | | |
| D | 279 | | |
| E | 350 | | |
| F | 90 | | |
| G | 566,5 | | |
| H | 72,5 | | |
| I | 570 | | |

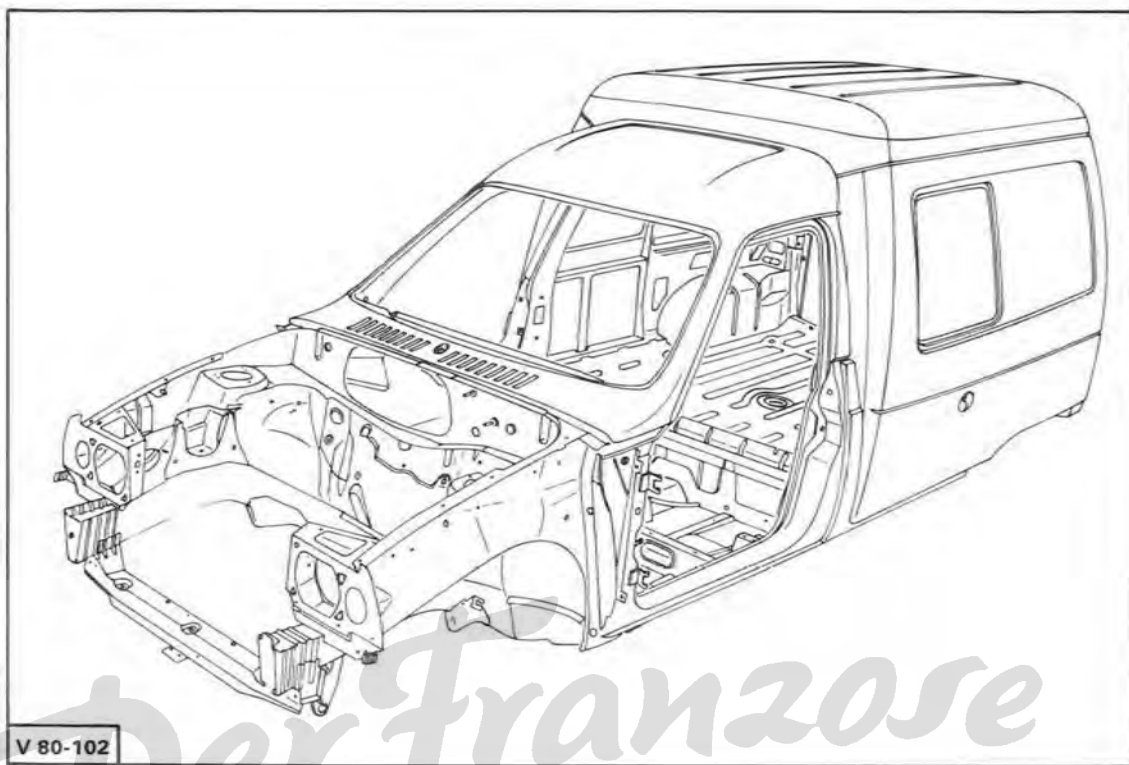

V 80-102

Der Franzose

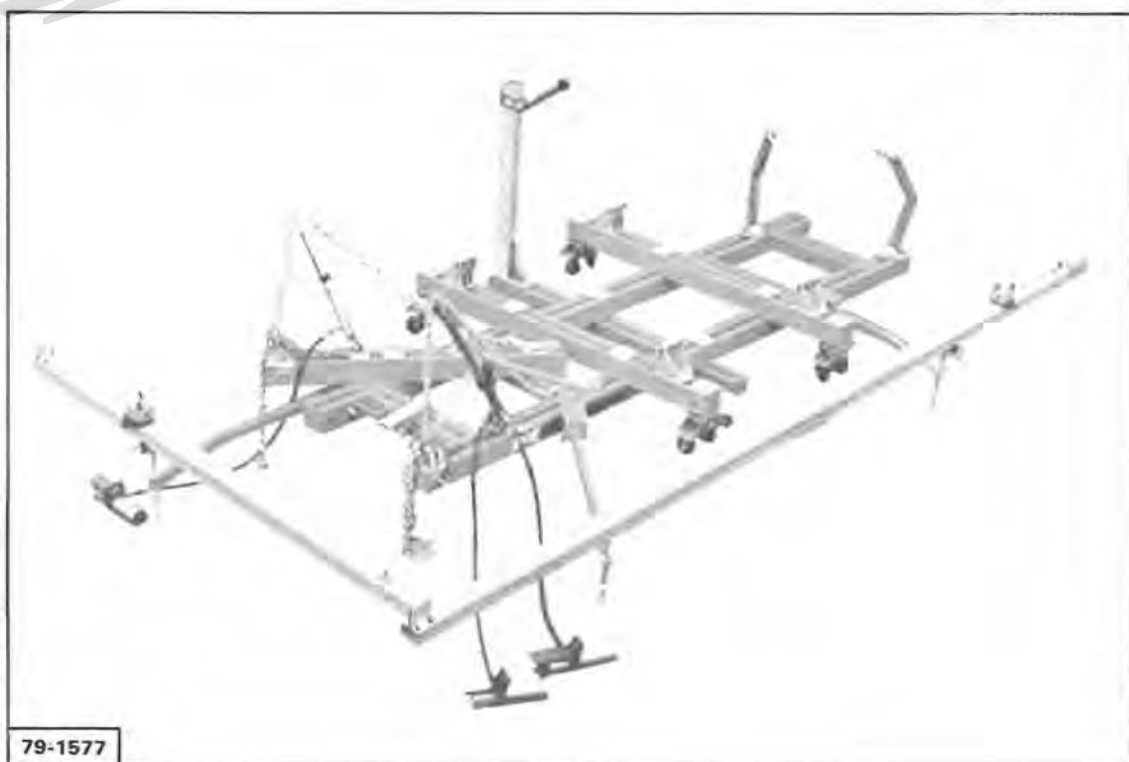

79-1577

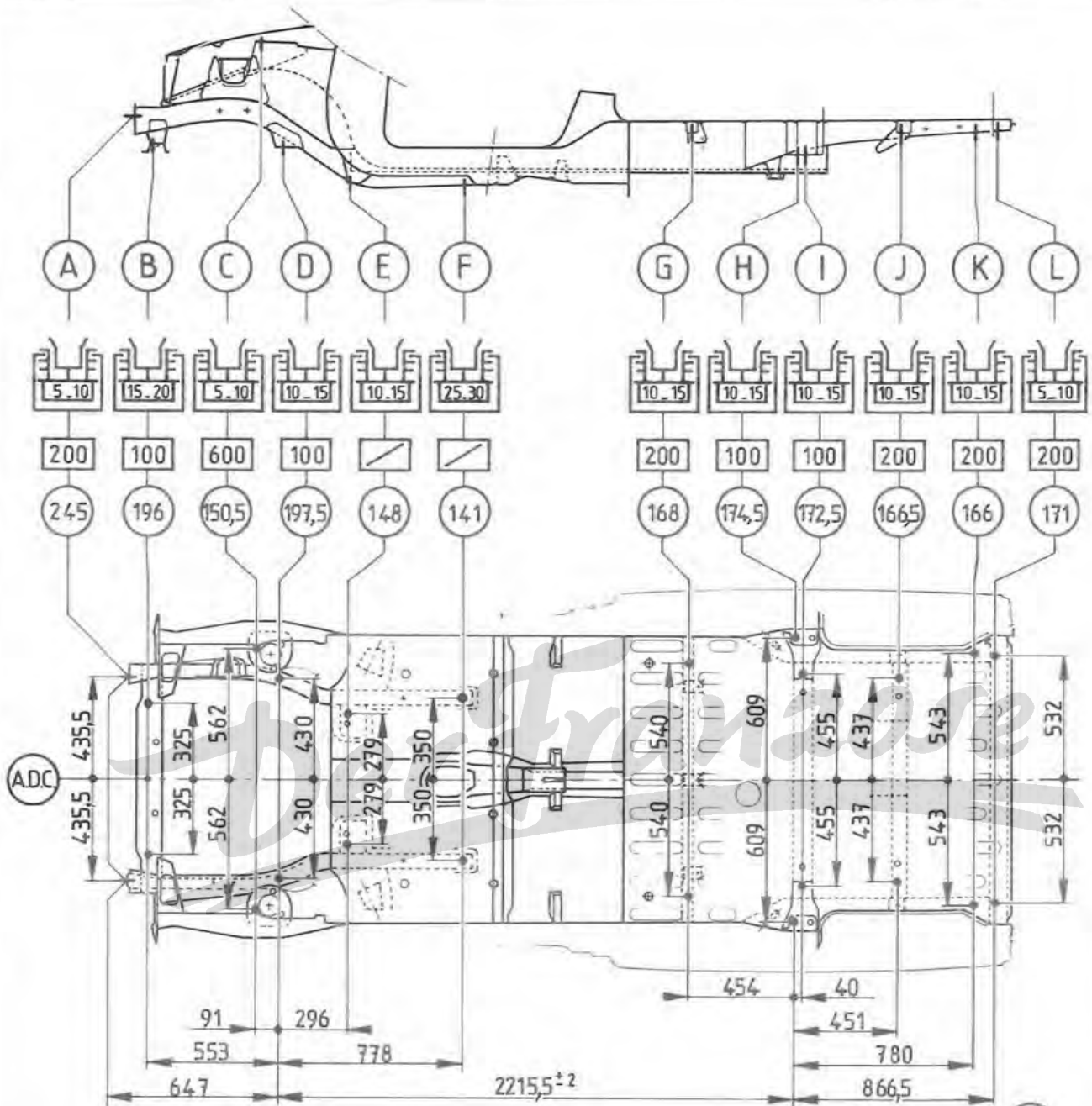

Hauteur

Longueur

Largeur / ADC

| Réf. | Nominal | Déviaton Gauche | Déviaton Droite |
|------|---------|--------------------|--------------------|
| A | 245 | | |
| B | 196 | | |
| C | 150,5 | | |
| D | 197,5 | | |
| E | 148 | | |
| F | 141 | | |

| Réf. | Nominal | Déviaton Gauche | Déviaton Droite |
|------|---------|--------------------|--------------------|
| A.D | 647 | | |
| B..D | 553 | | |
| C..D | 91 | | |
| D | 0 | | |
| E..D | 296 | | |
| F..D | 778 | | |
| G..H | 454 | | |
| H..D | 2215,5 | | |
| I..H | 40 | | |
| J..H | 451 | | |
| K..H | 780 | | |
| L..H | 866,5 | | |

| Réf. | Nominal | Déviaton Gauche | Déviaton Droite |
|------|---------|--------------------|--------------------|
| A | 435,5 | | |
| B | 325 | | |
| C | 562 | | |
| D | 430 | | |
| E | 279 | | |
| F | 350 | | |
| G | 540 | | |
| H | 609 | | |
| I | 455 | | |
| J | 437 | | |
| K | 543 | | |
| L | 532 | | |

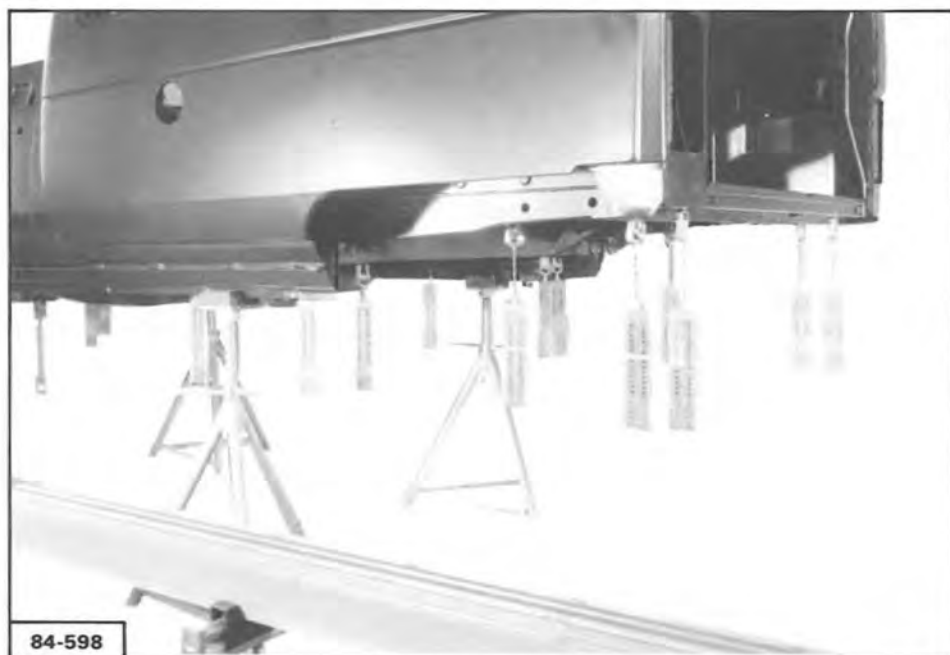
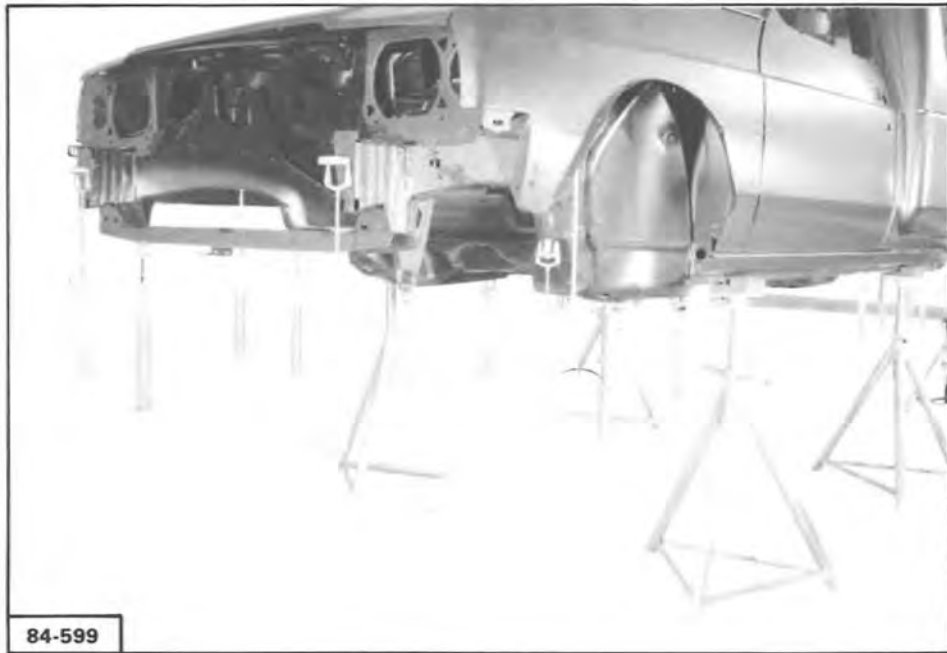



Der Franzose

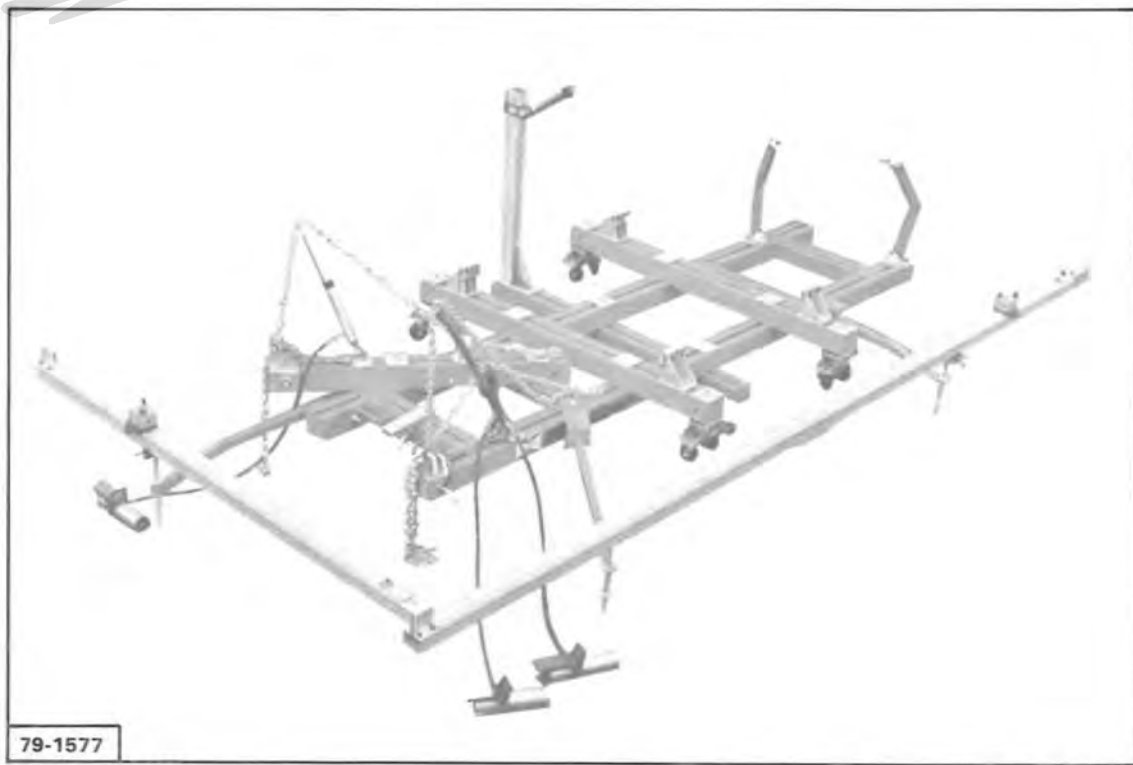

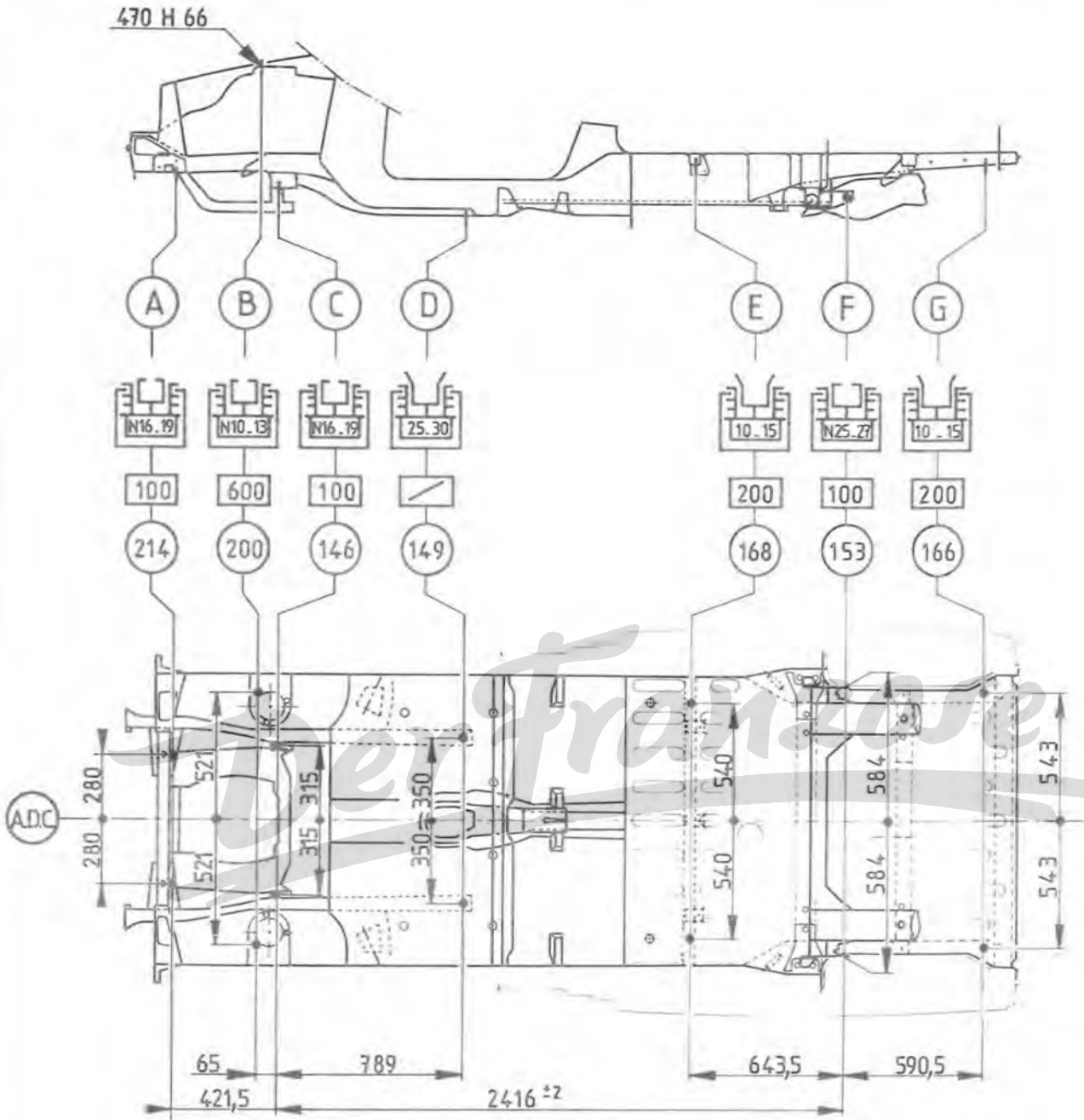
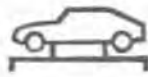

Hauteur

| Réf. | Nominal | Déviaton Gauche | Déviaton Droite |
|------|---------|--------------------|--------------------|
| A | 214 | | |
| B | 200 | | |
| C | 146 | | |
| D | 149 | | |
| E | 168 | | |
| F | 153 | | |
| G | 166 | | |
| | | | |
| | | | |

Longueur

| Réf. | Nominal | Déviaton Gauche | Déviaton Droite |
|------|---------|--------------------|--------------------|
| A-C | 421,5 | | |
| B-C | 65 | | |
| C | 0 | | |
| D-C | 789 | | |
| E-F | 643,5 | | |
| F-C | 2416 | | |
| G-F | 590,5 | | |
| | | | |
| | | | |

Largeur / ADC

| Réf. | Nominal | Déviaton Gauche | Déviaton Droite |
|------|---------|--------------------|--------------------|
| A | 280 | | |
| B | 521 | | |
| C | 315 | | |
| D | 350 | | |
| E | 540 | | |
| F | 584 | | |
| G | 543 | | |
| | | | |
| | | | |

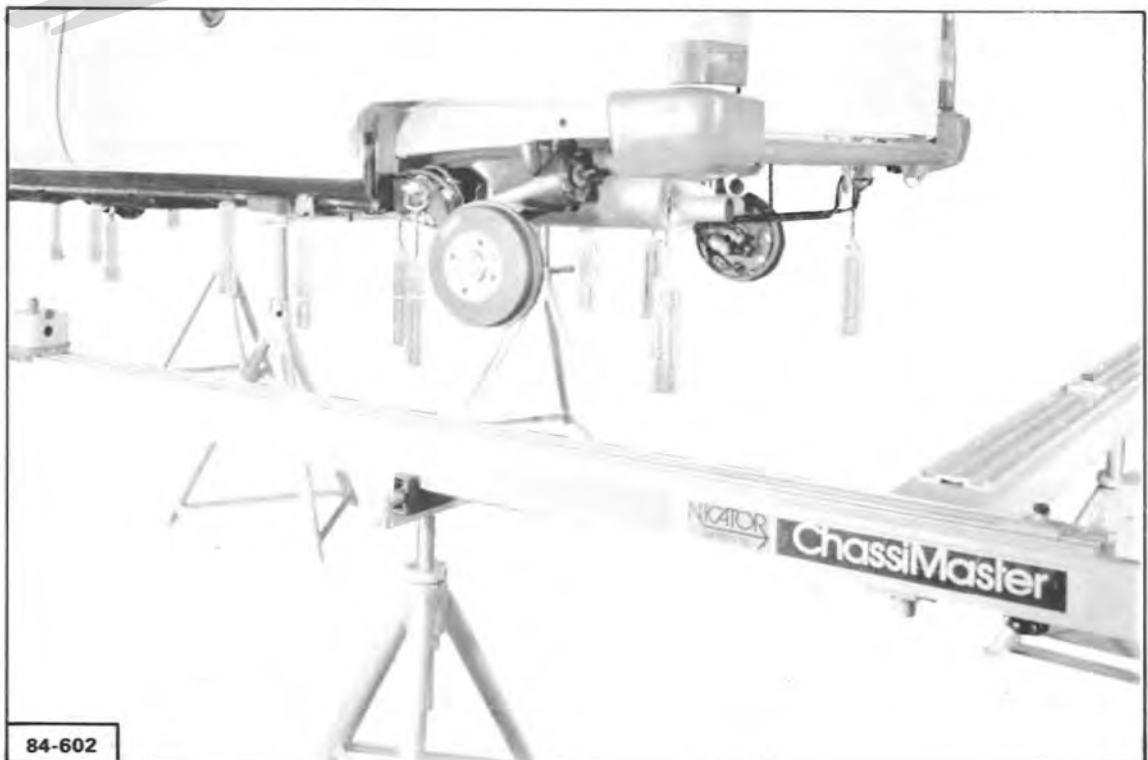



84-705

Der Franzose

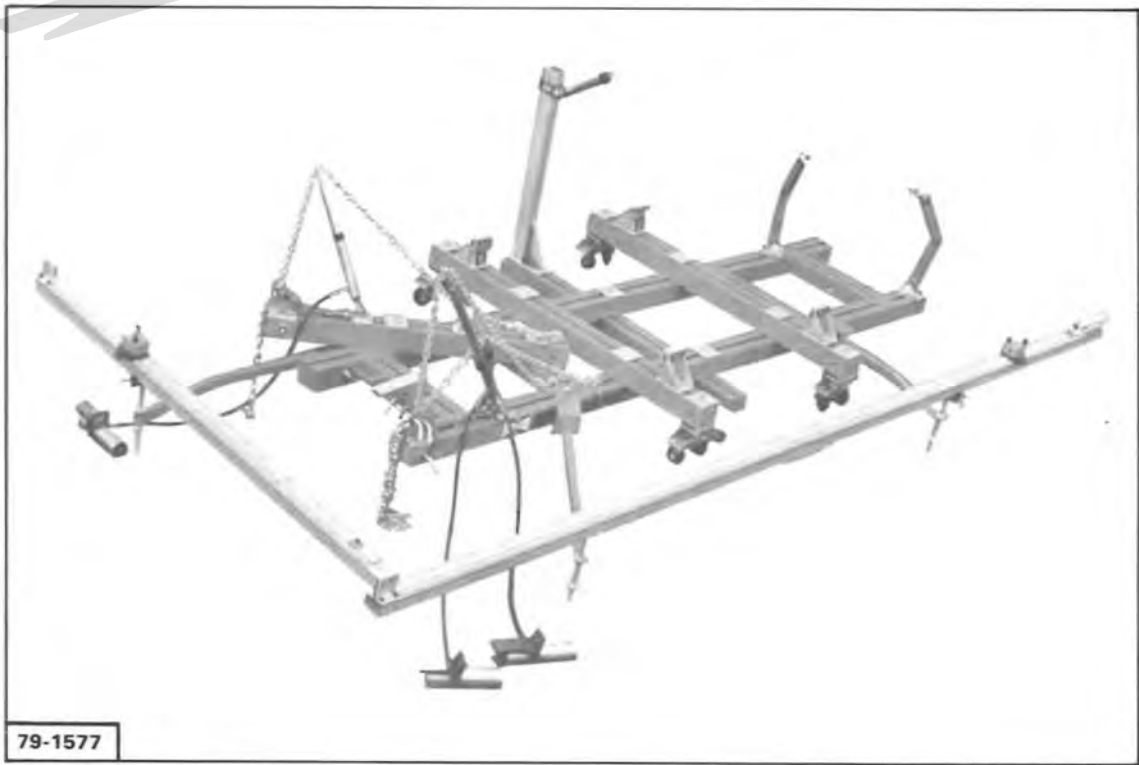

79-1577

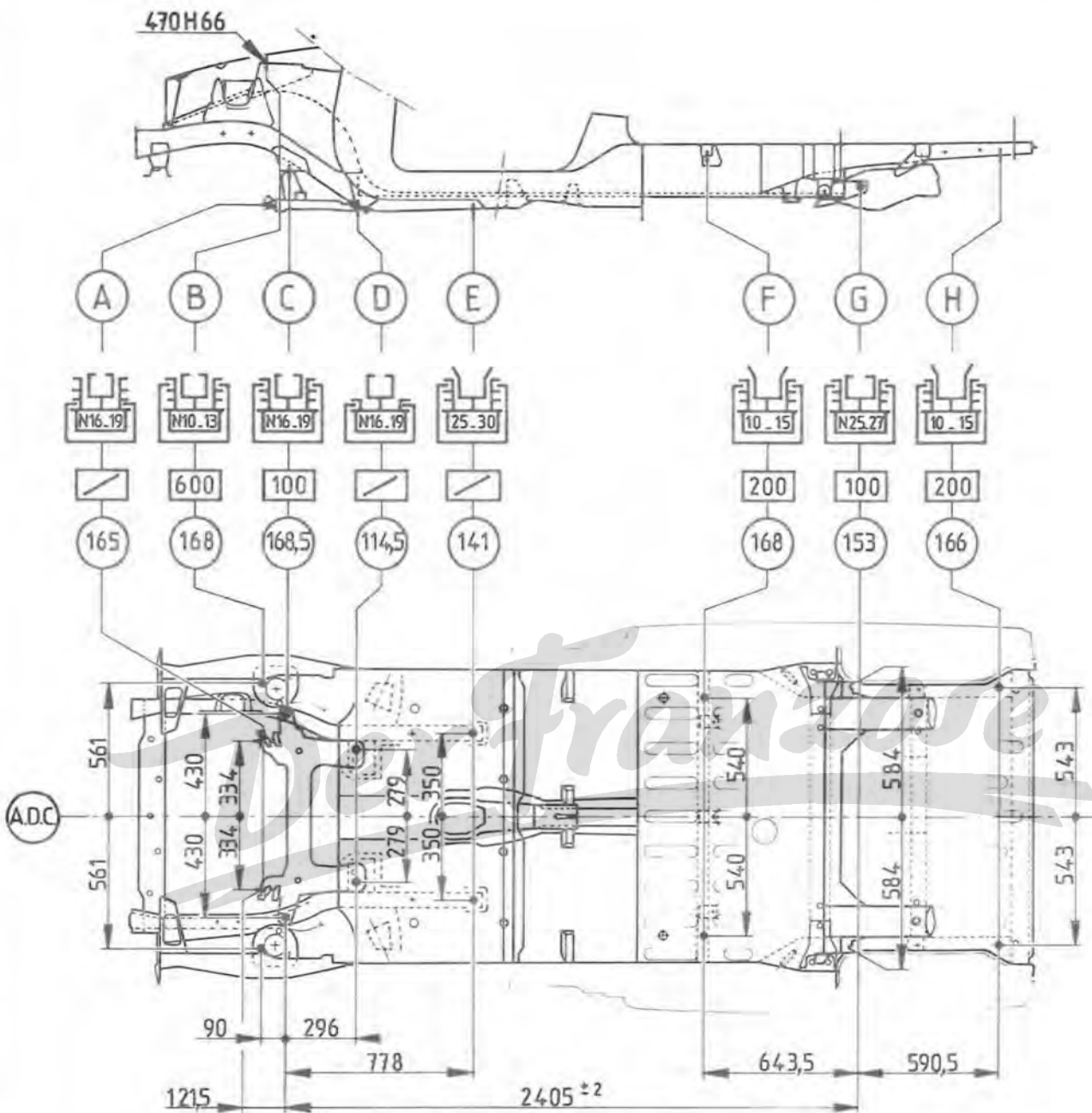

Hauteur

| Réf. | Nominal | Déviaton Gauche | Déviaton Droite |
|------|---------|--------------------|--------------------|
| A | 165 | | |
| B | 168 | | |
| C | 168,5 | | |
| D | 114,5 | | |
| E | 141 | | |
| F | 168 | | |
| G | 153 | | |
| H | 166 | | |

Longueur

| Réf. | Nominal | Déviaton Gauche | Déviaton Droite |
|------|---------|--------------------|--------------------|
| A.C | 121,5 | | |
| B.C | 90 | | |
| C | 0 | | |
| D.C | 296 | | |
| E.C | 778 | | |
| F.G | 643,5 | | |
| G.C | 2405 | | |
| H.G | 590,5 | | |

Largeur/ADC

| Réf. | Nominal | Déviaton Gauche | Déviaton Droite |
|------|---------|--------------------|--------------------|
| A | 334 | | |
| B | 561 | | |
| C | 430 | | |
| D | 279 | | |
| E | 350 | | |
| F | 540 | | |
| G | 584 | | |
| H | 543 | | |



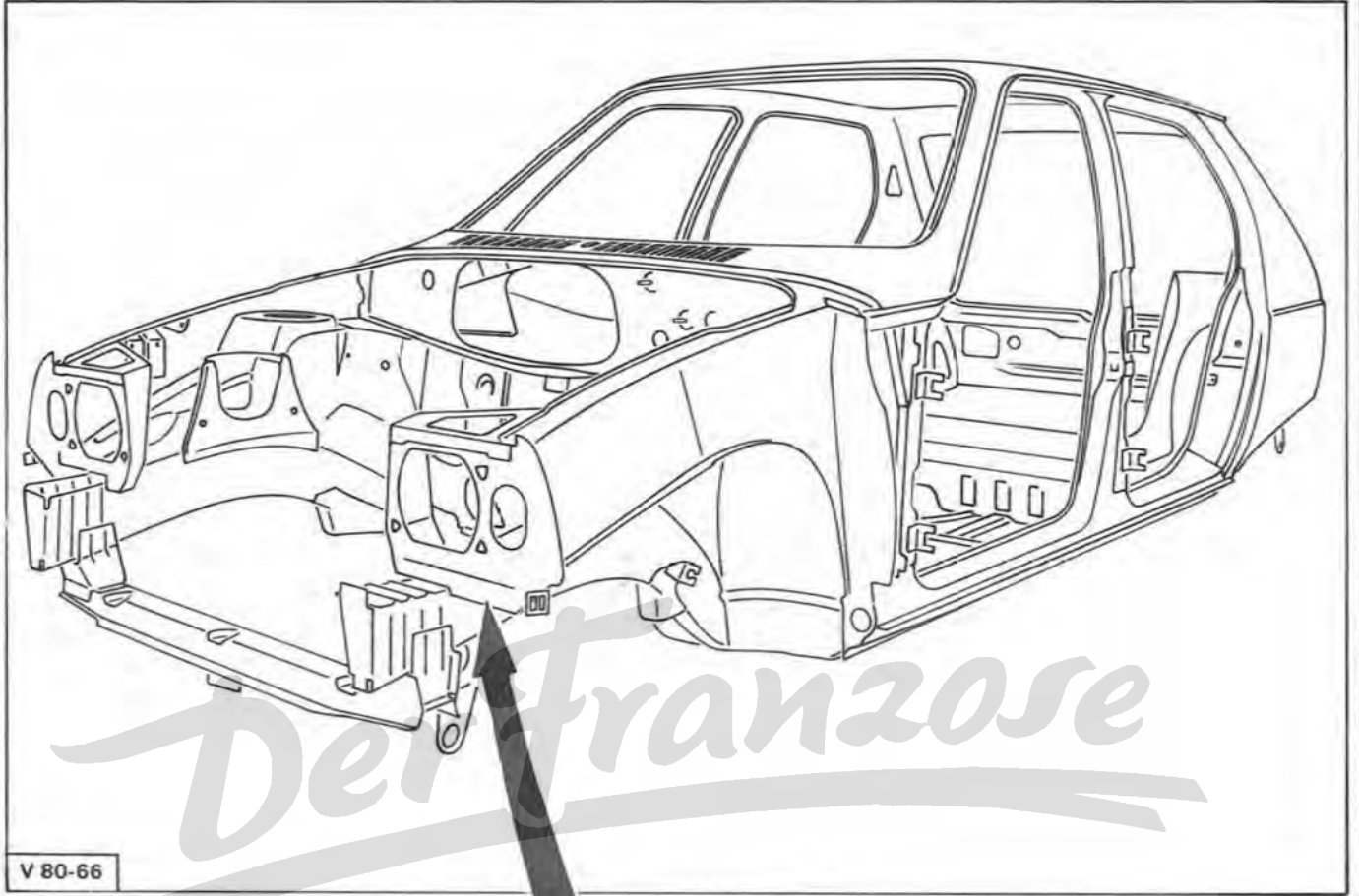

V 80-66

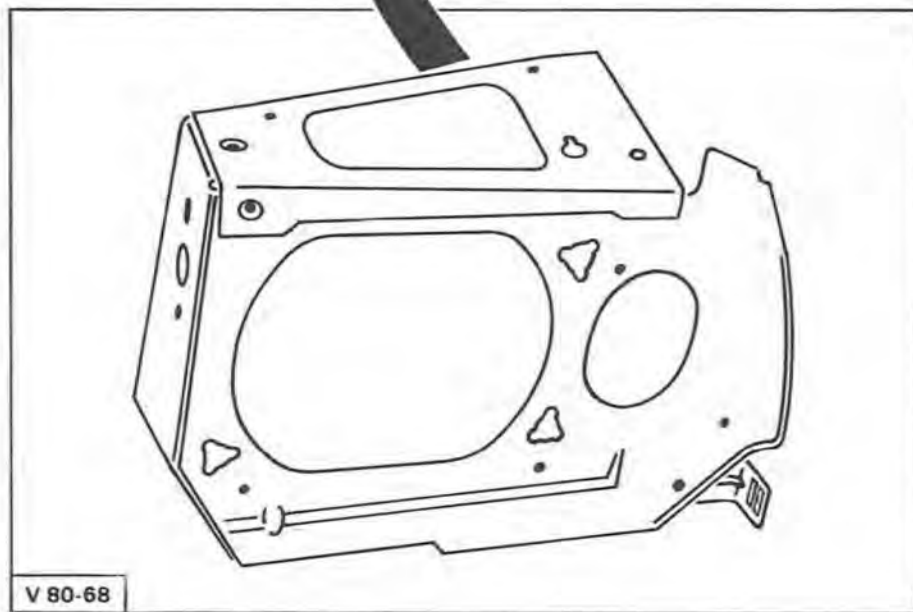

V 80-68

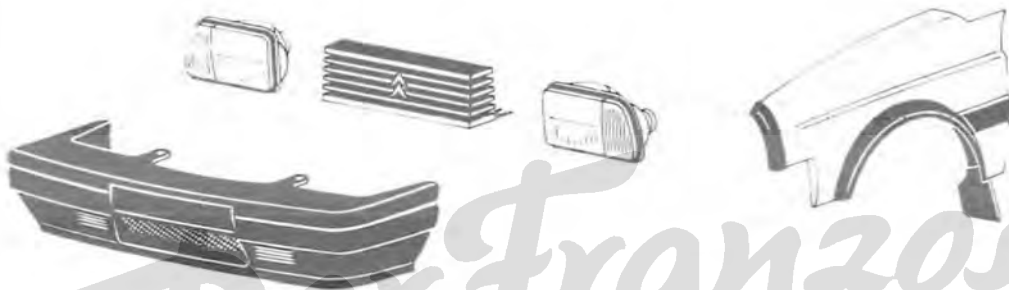
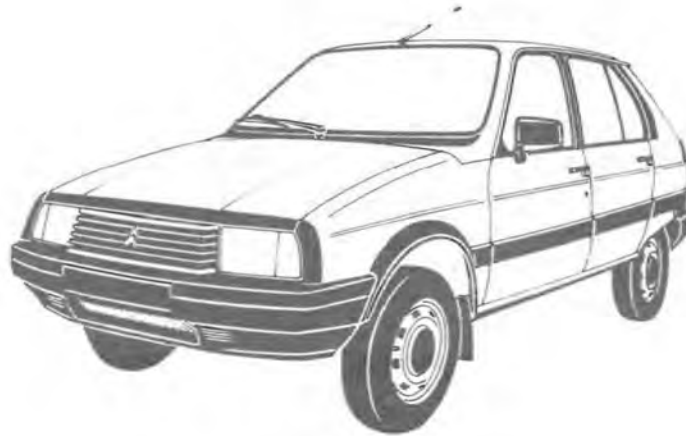

V 80-73

Der Franzose

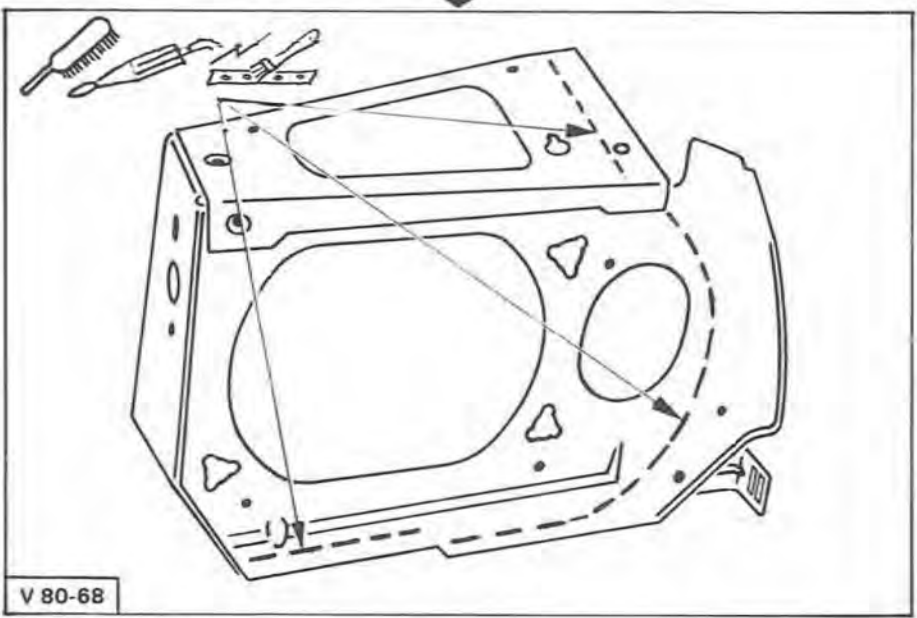
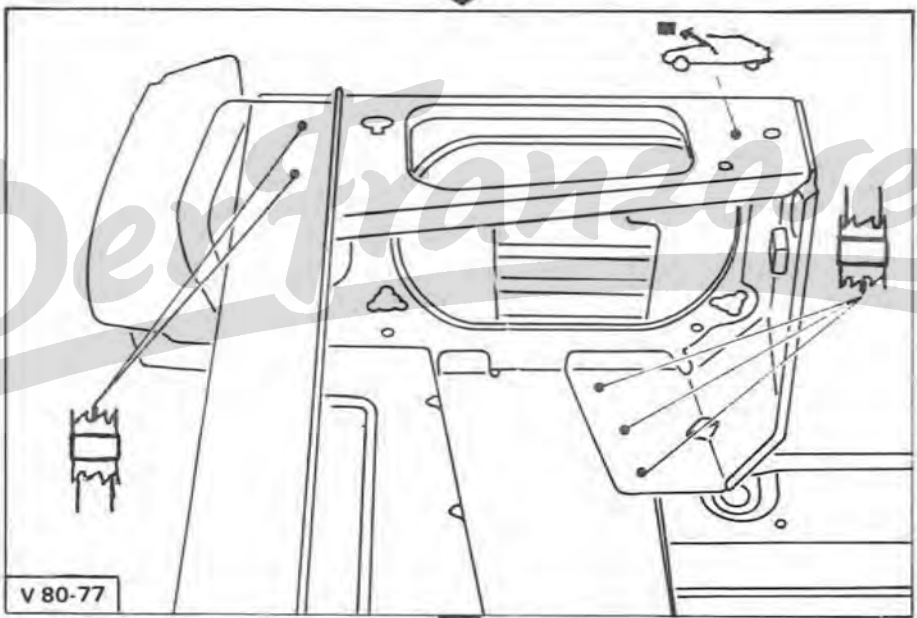
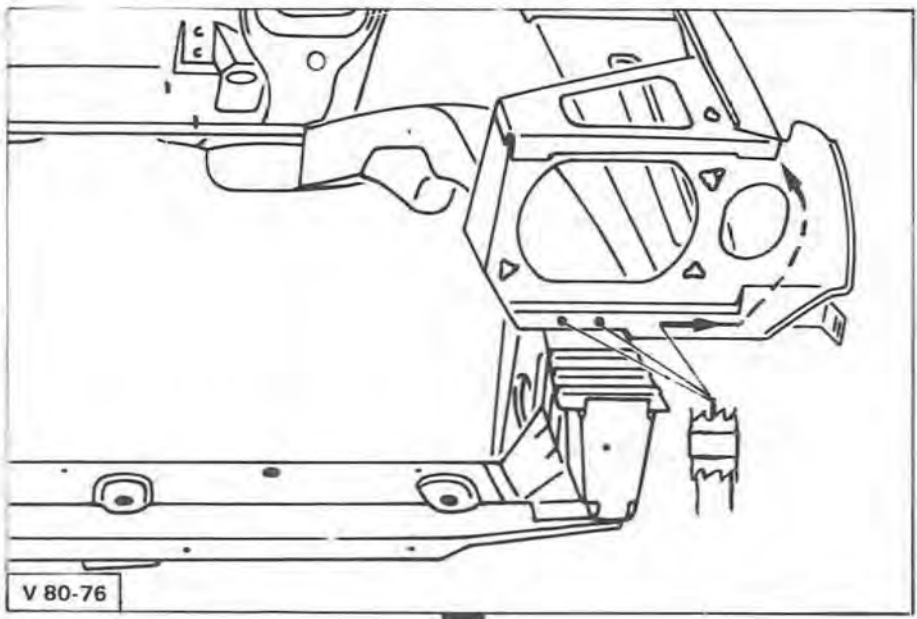

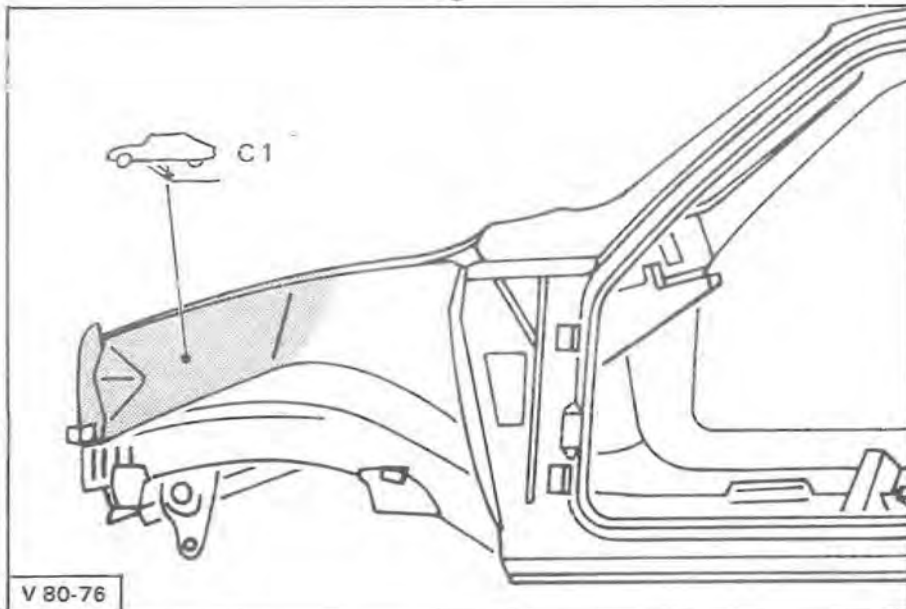
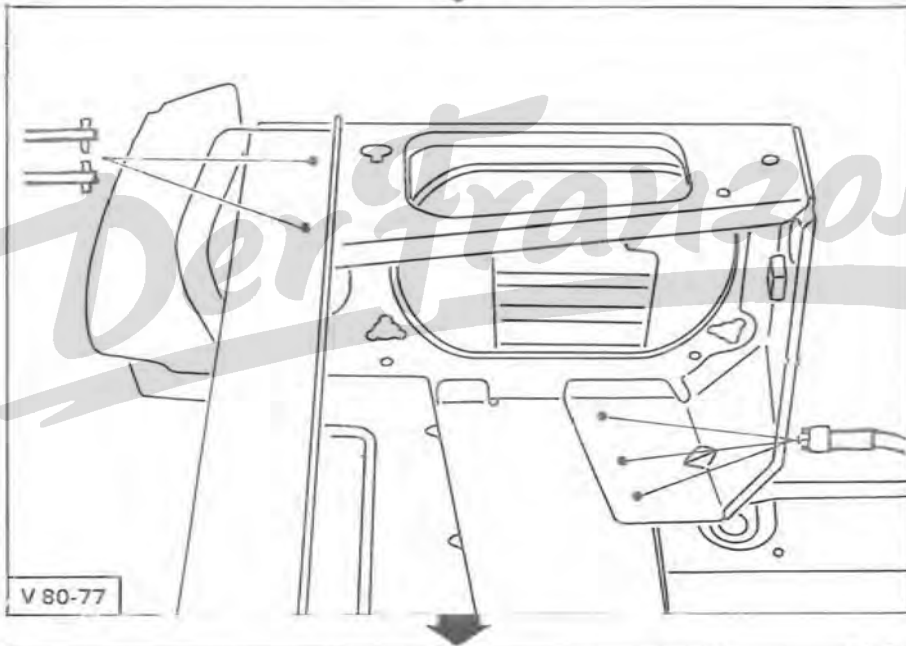
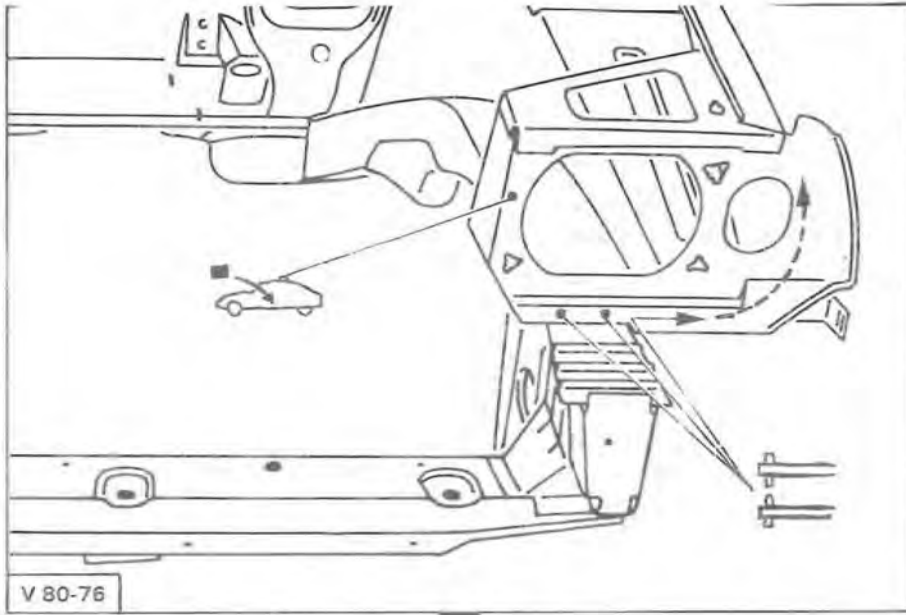

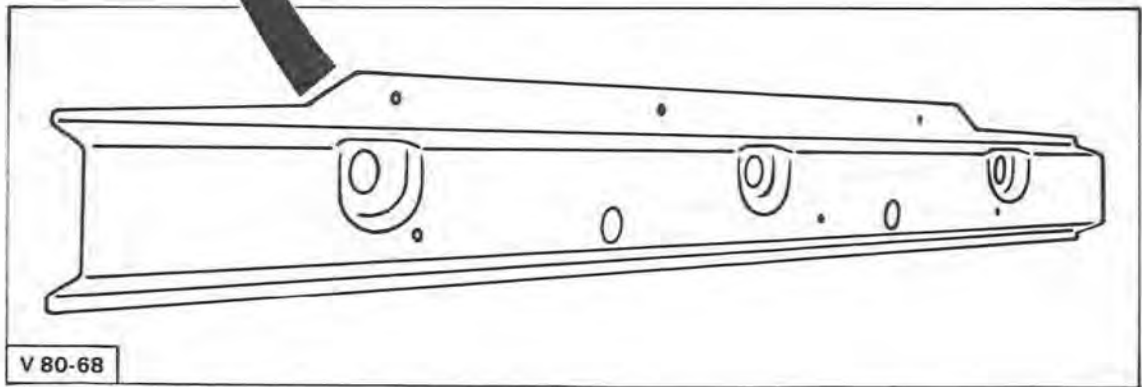
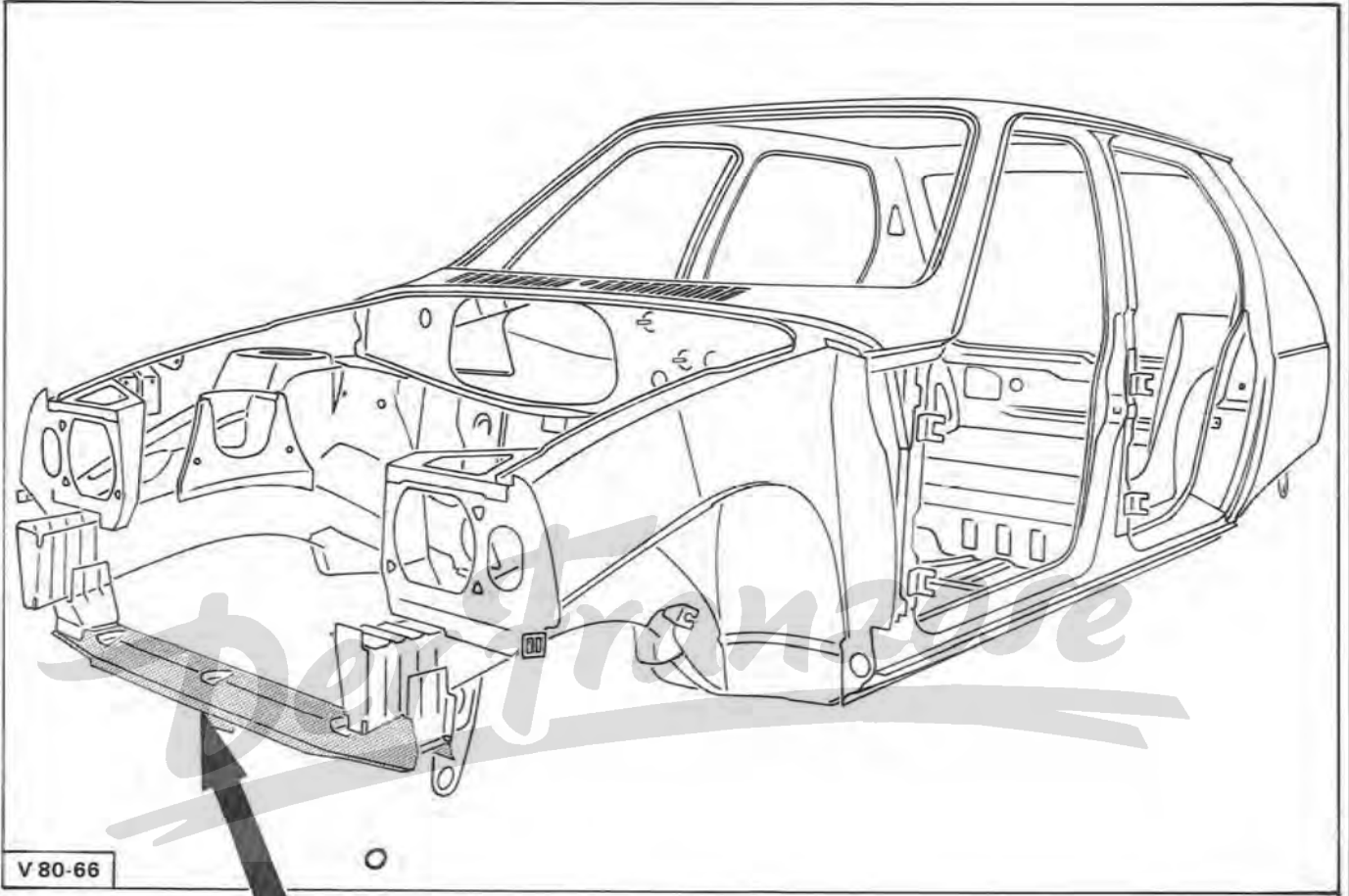

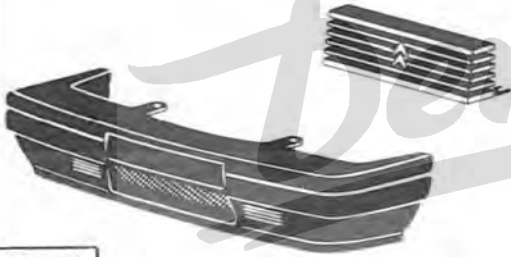
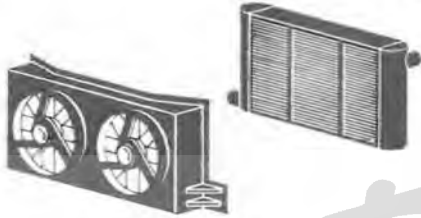
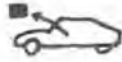

Der Franzose

V 80-73

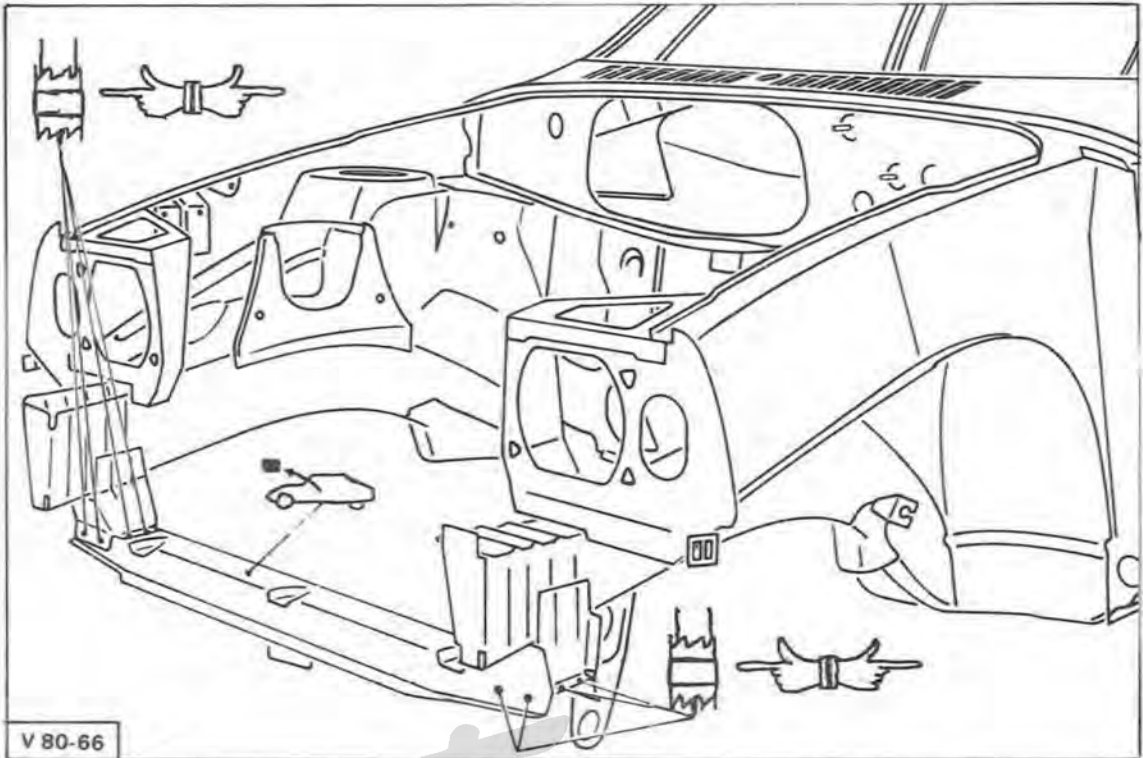

V 80-66

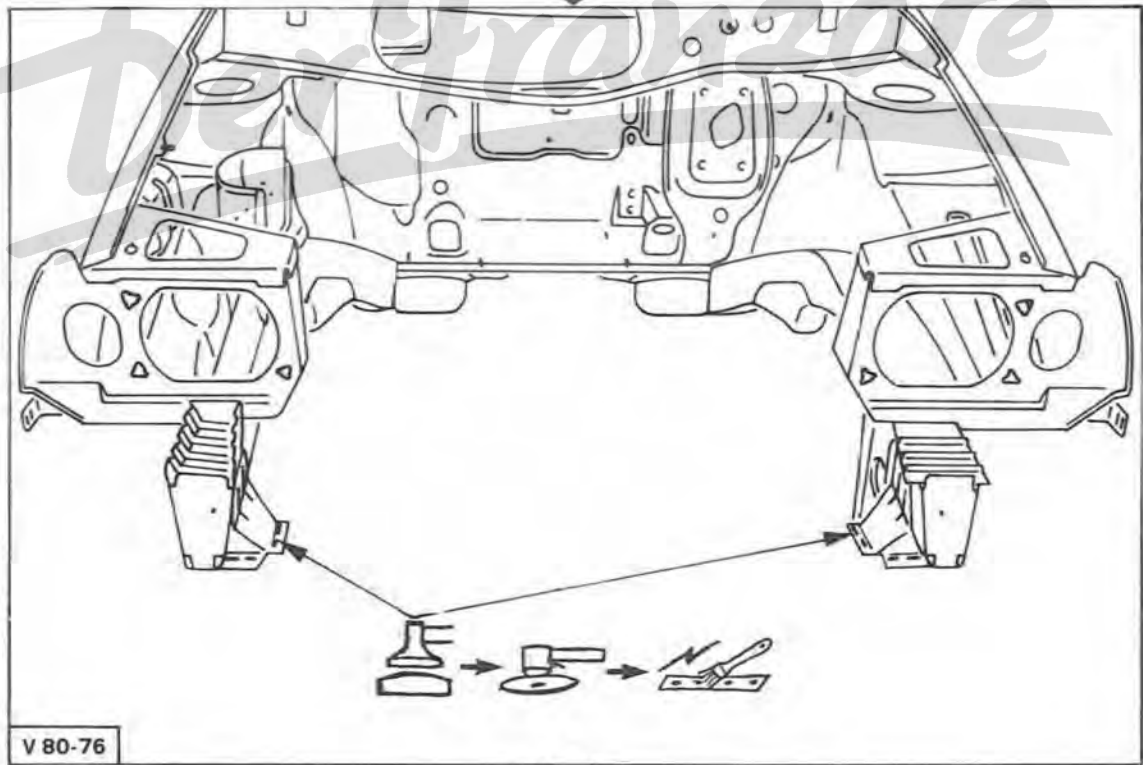

V 80-76

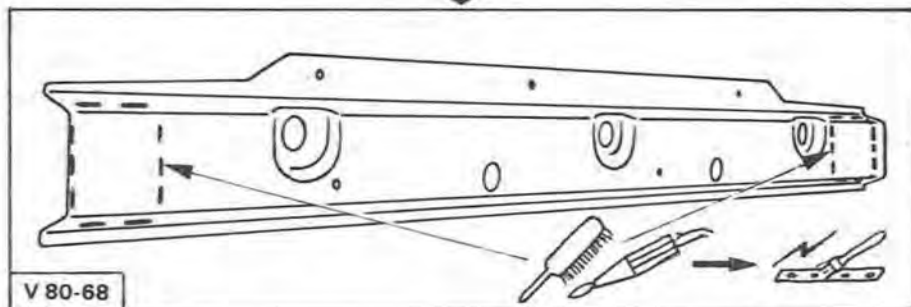

V 80-68

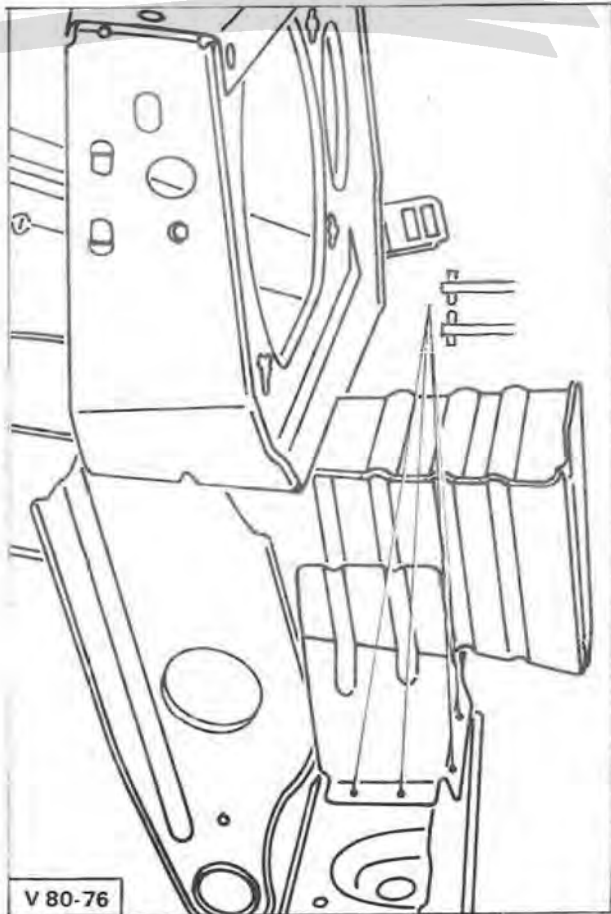
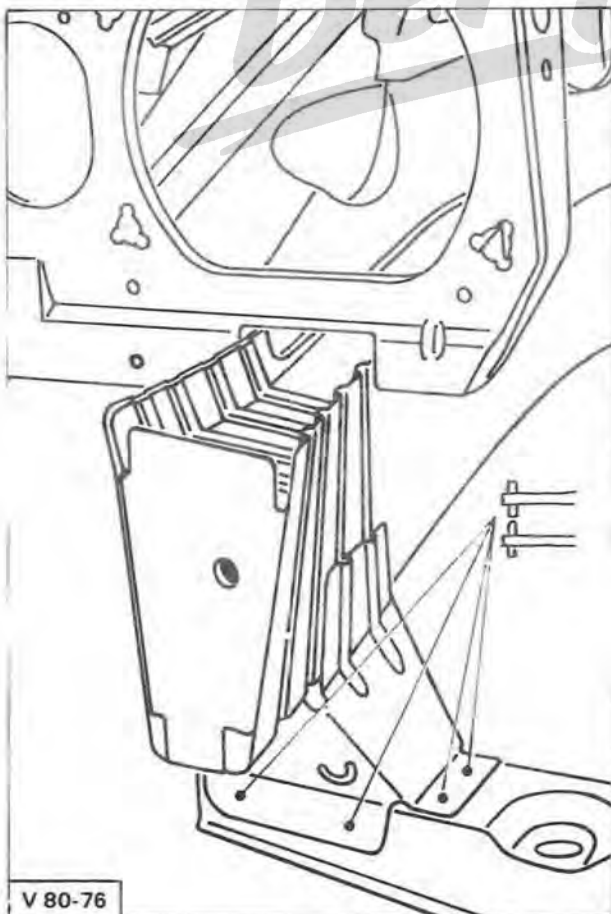
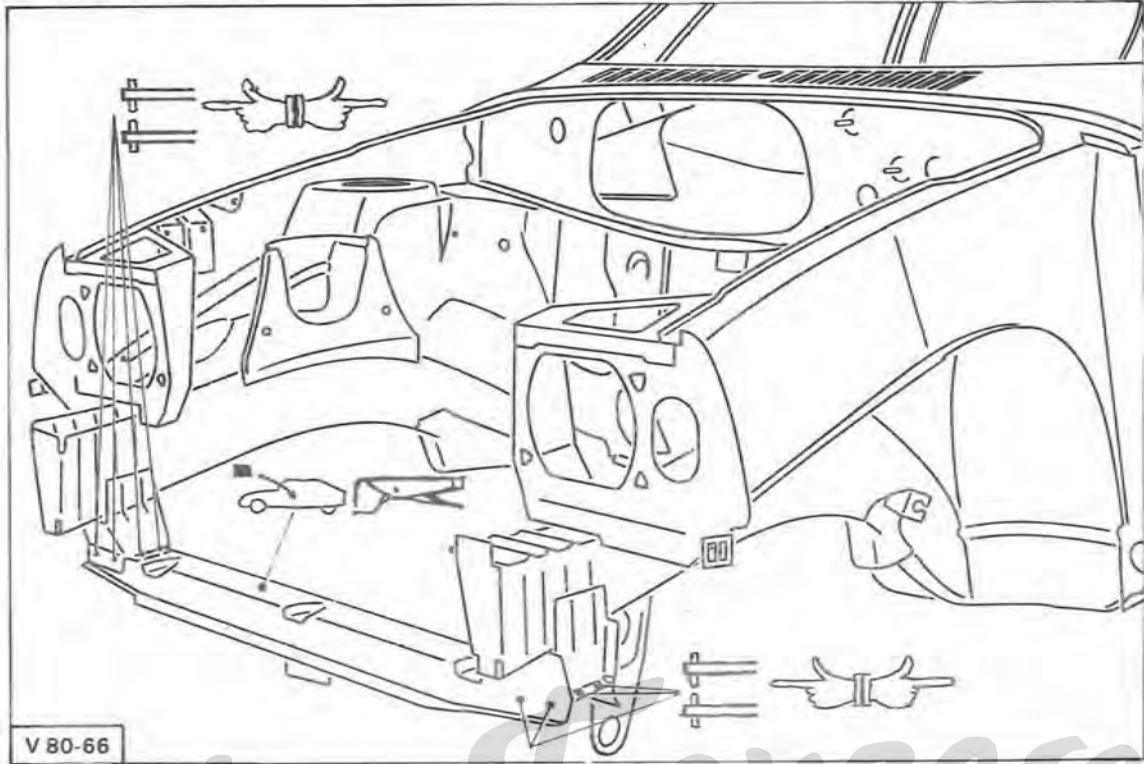

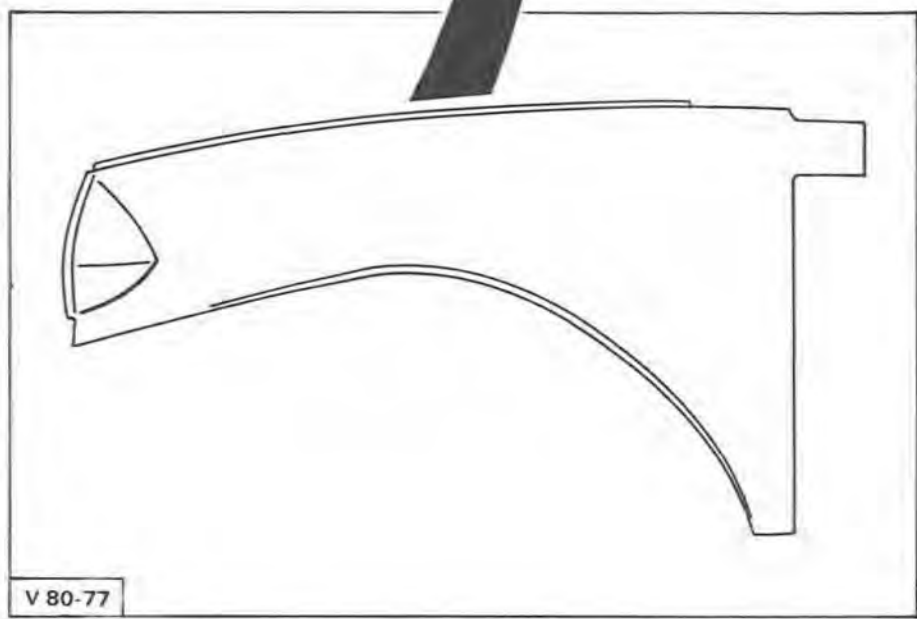
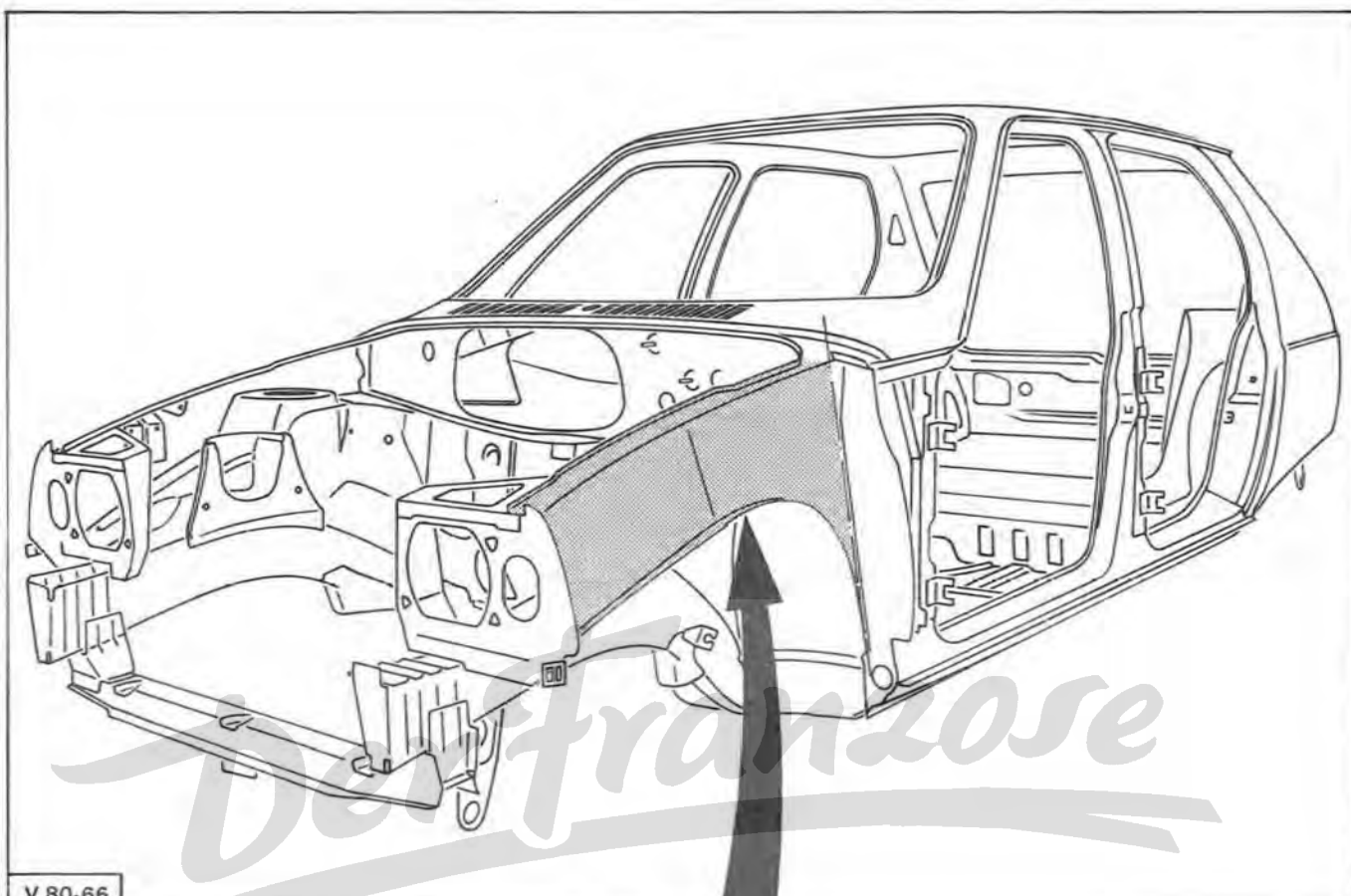

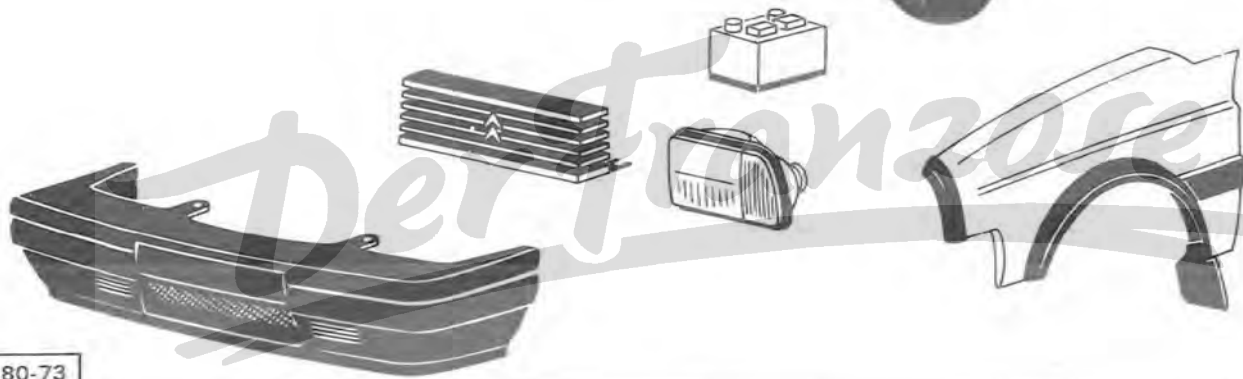
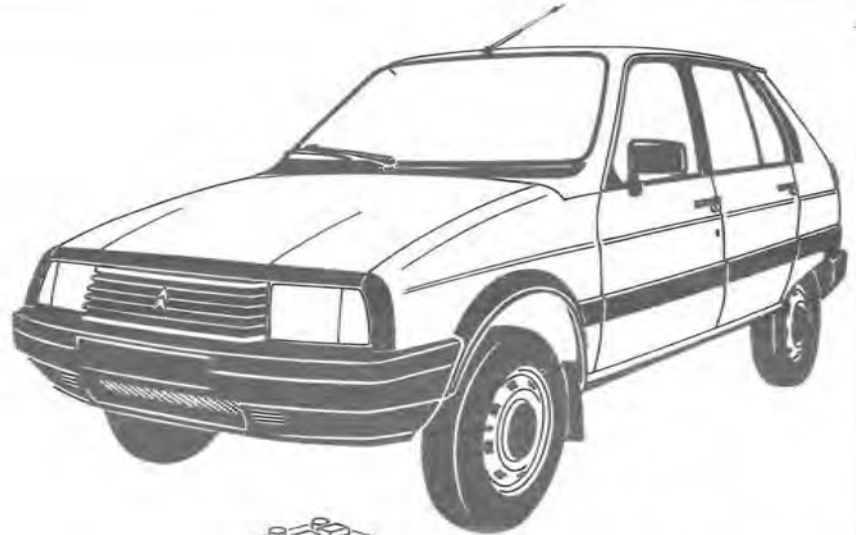
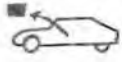

V 80-73

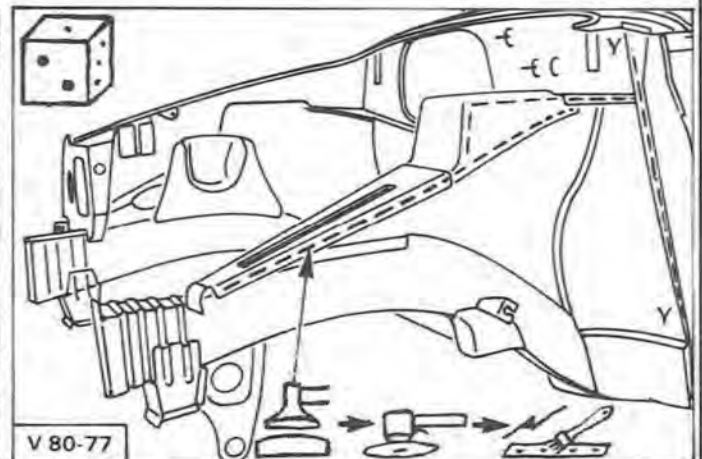
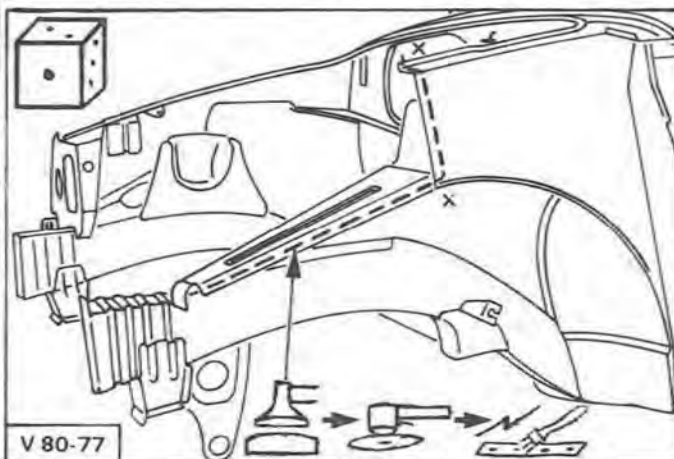
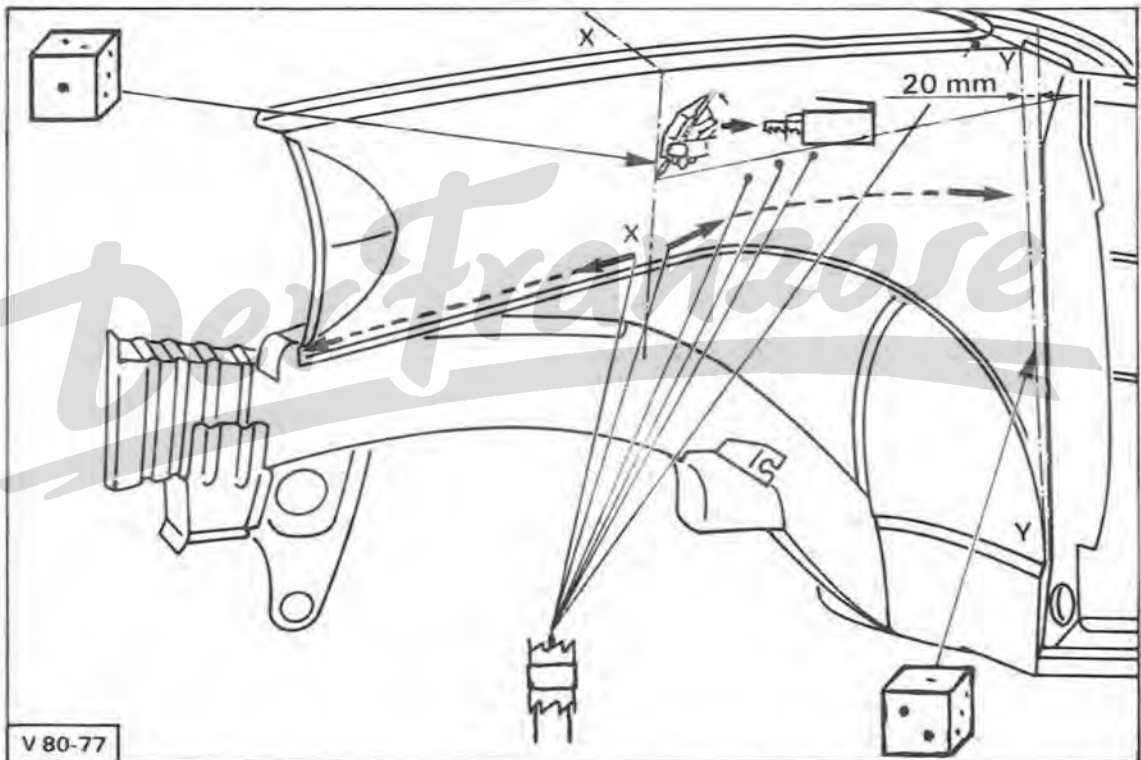
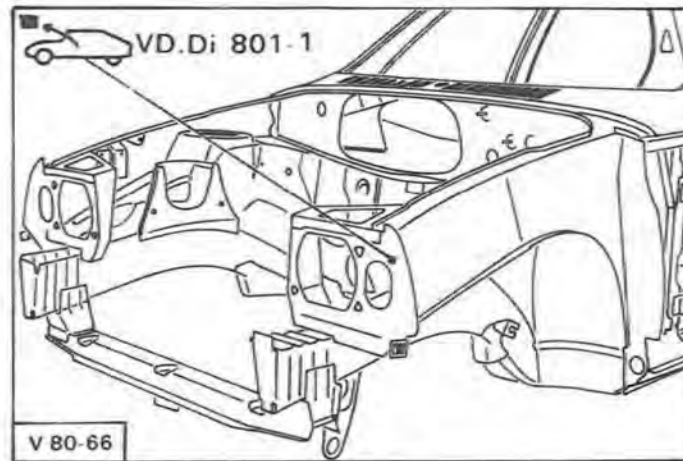

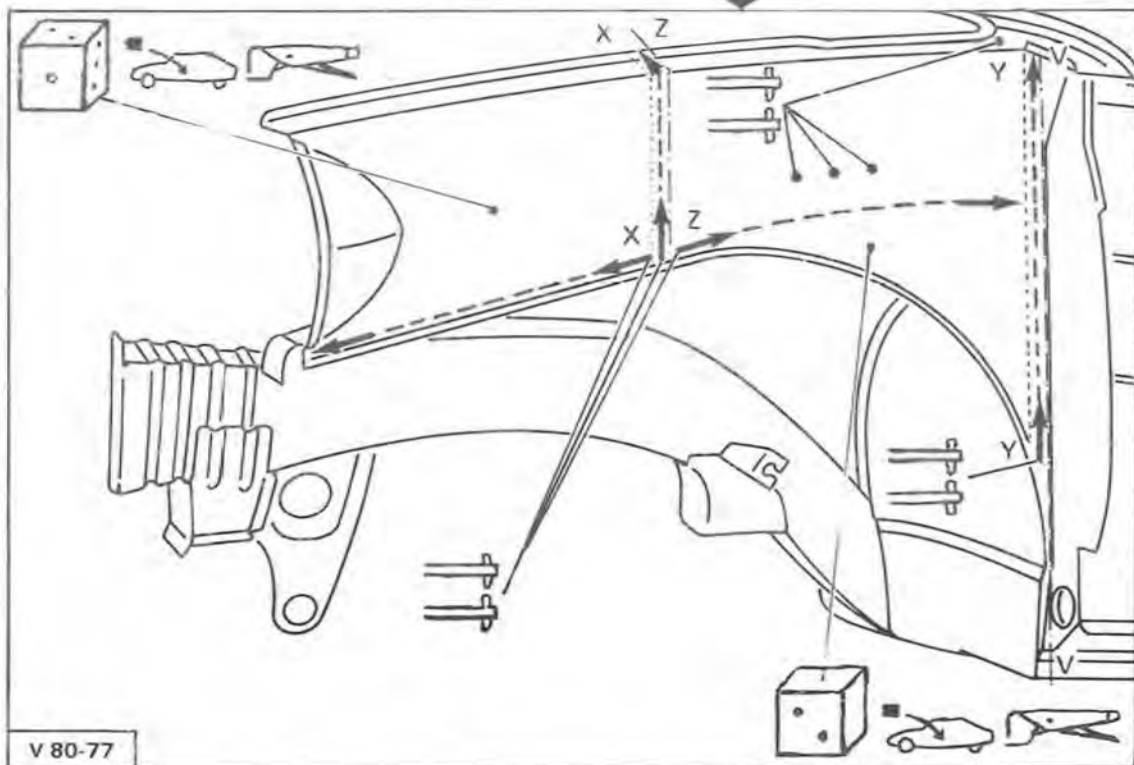
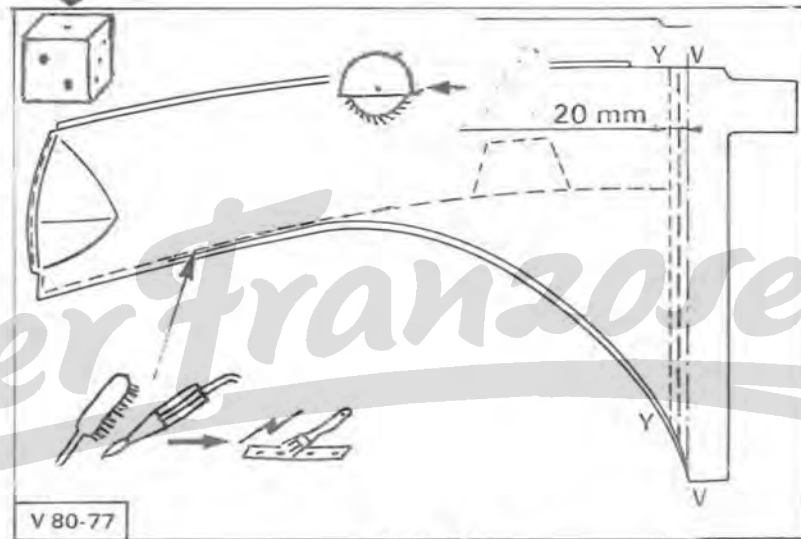
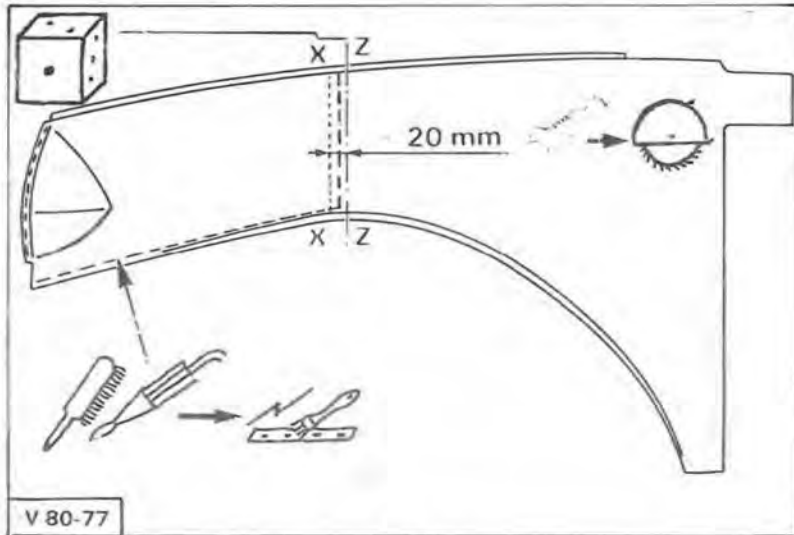

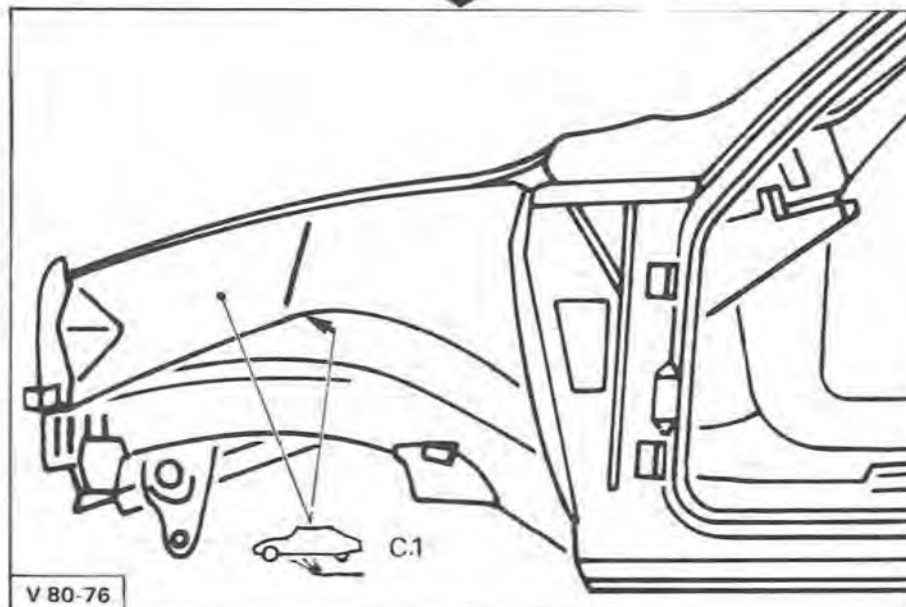
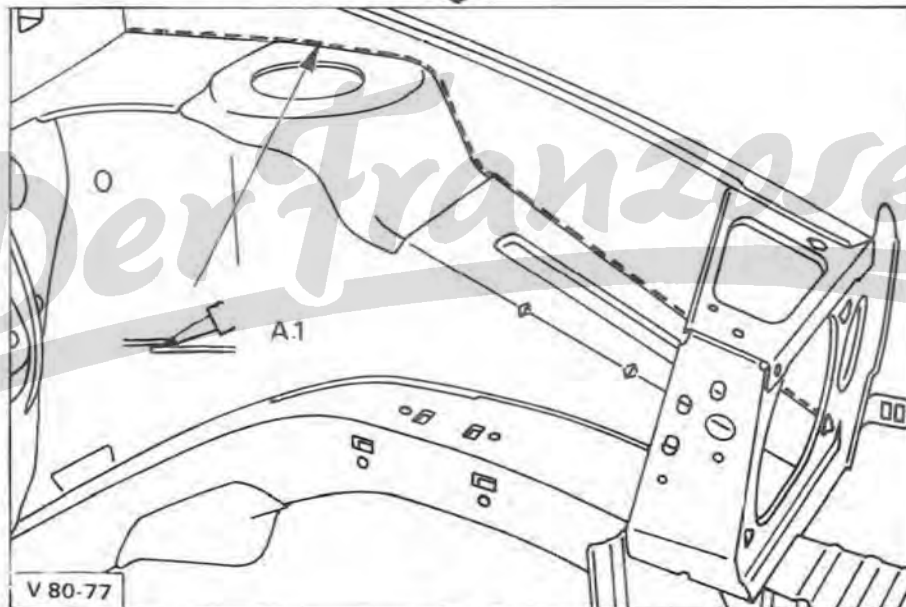
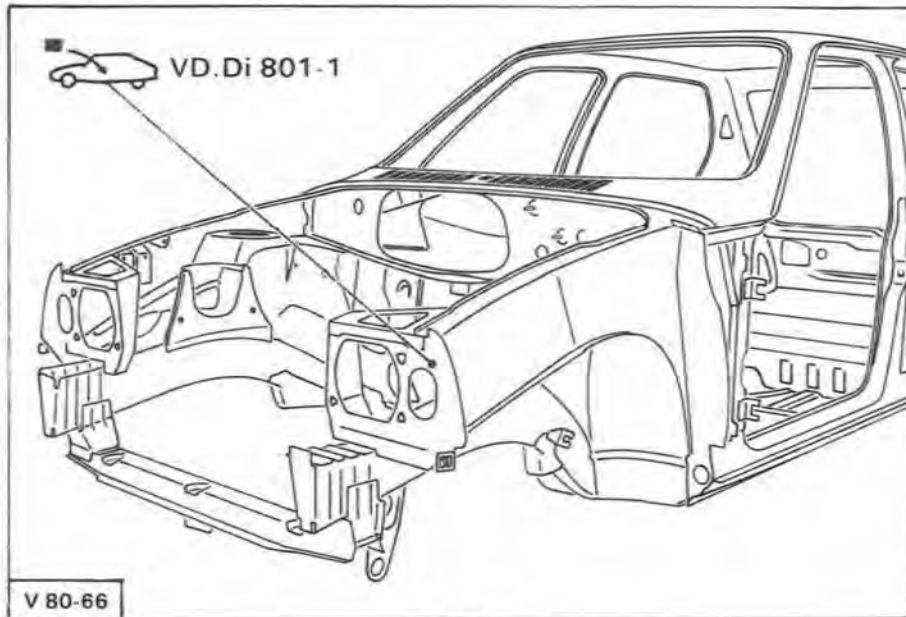

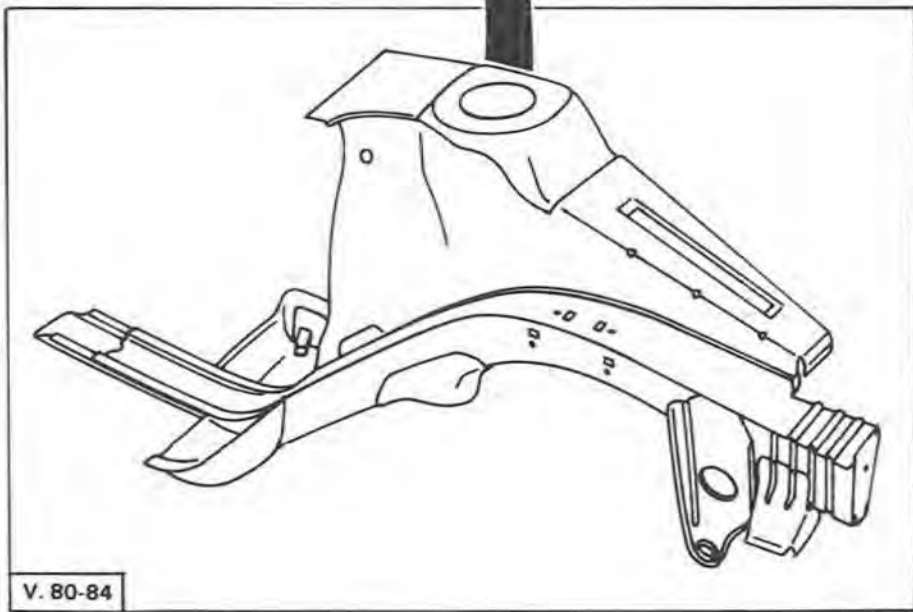
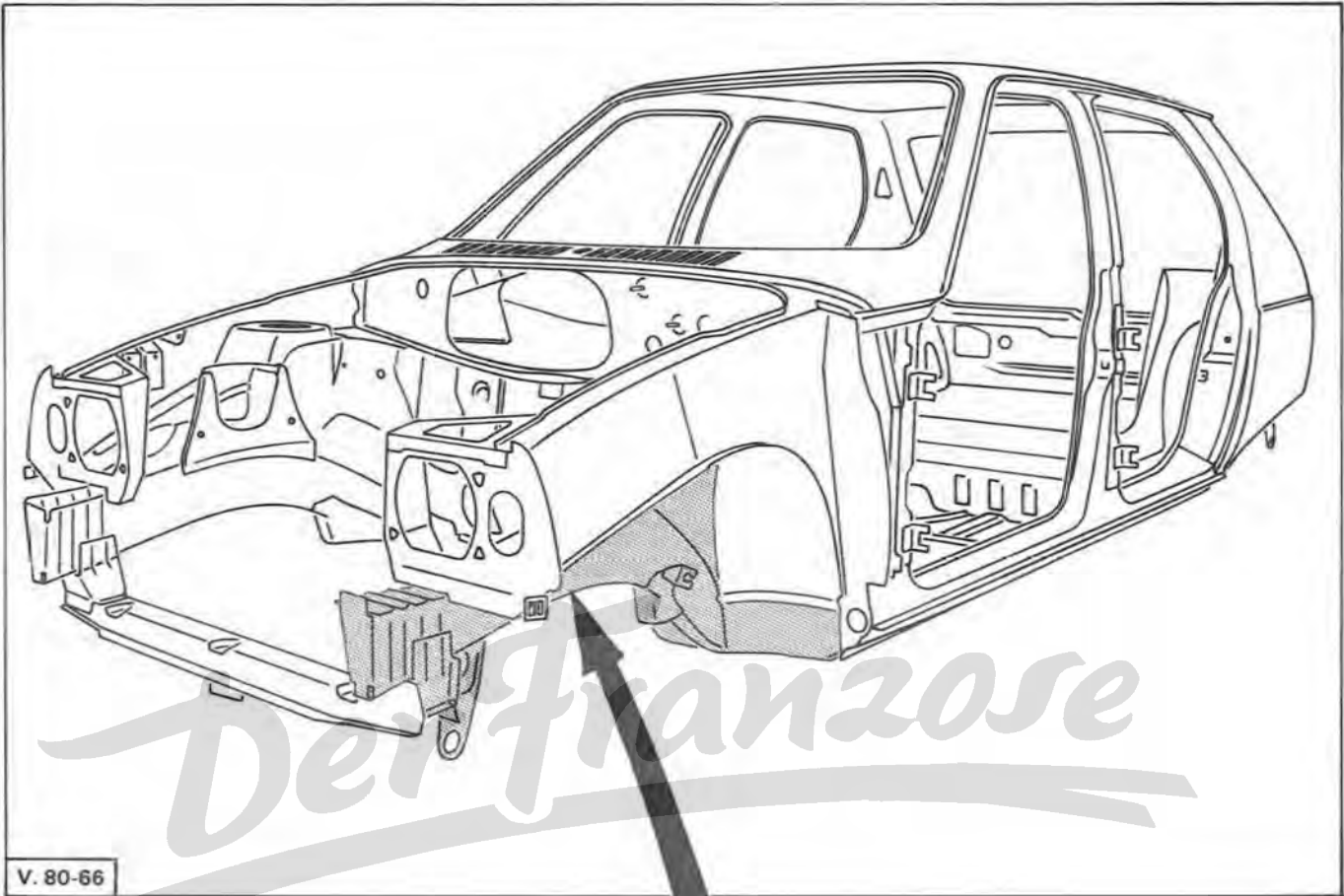

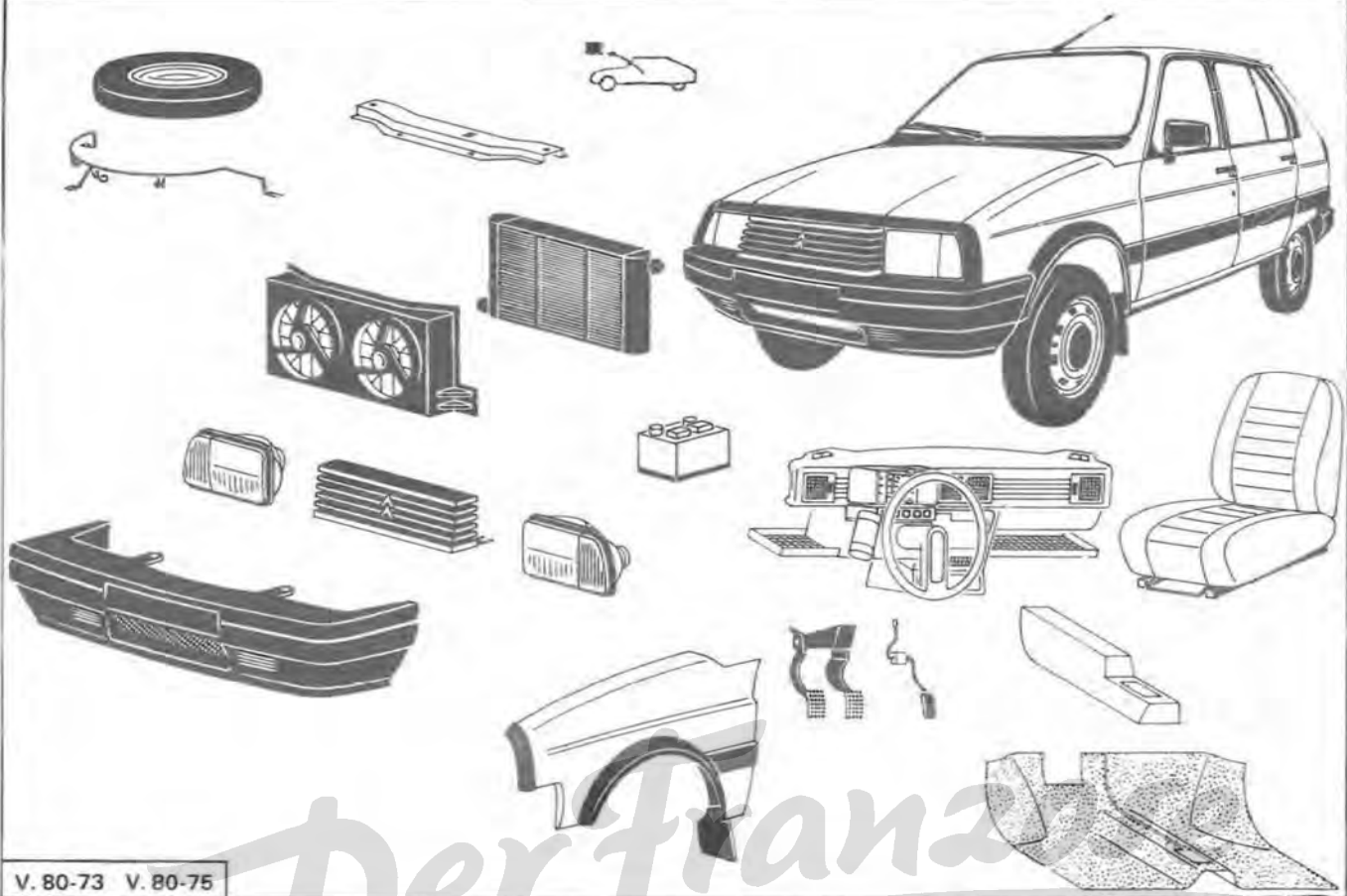
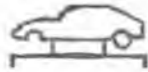

V. 80-73 V. 80-75

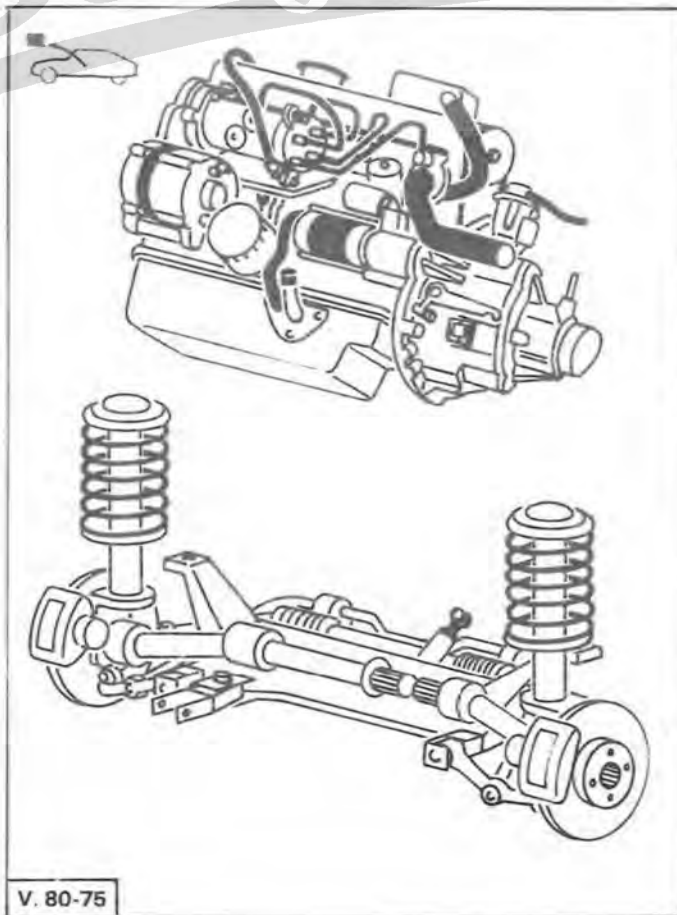

V. 80-75

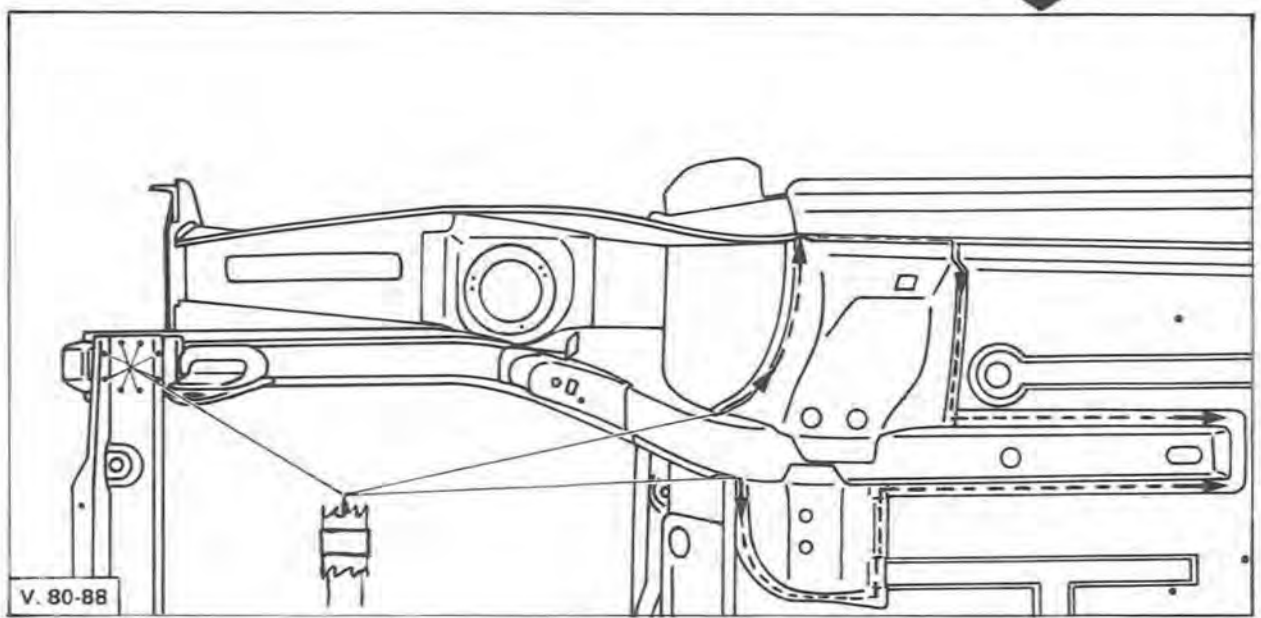
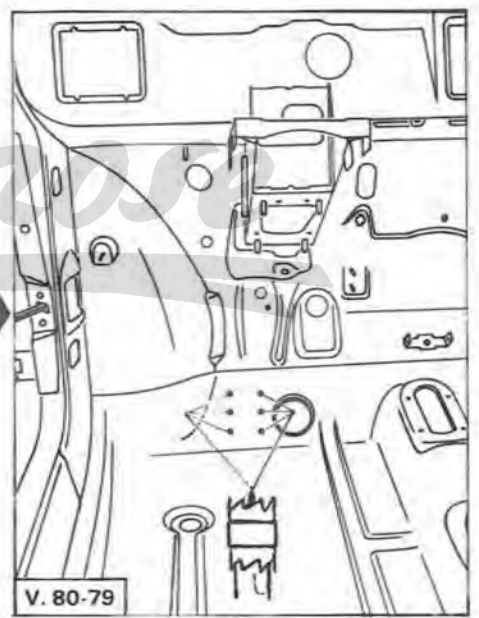
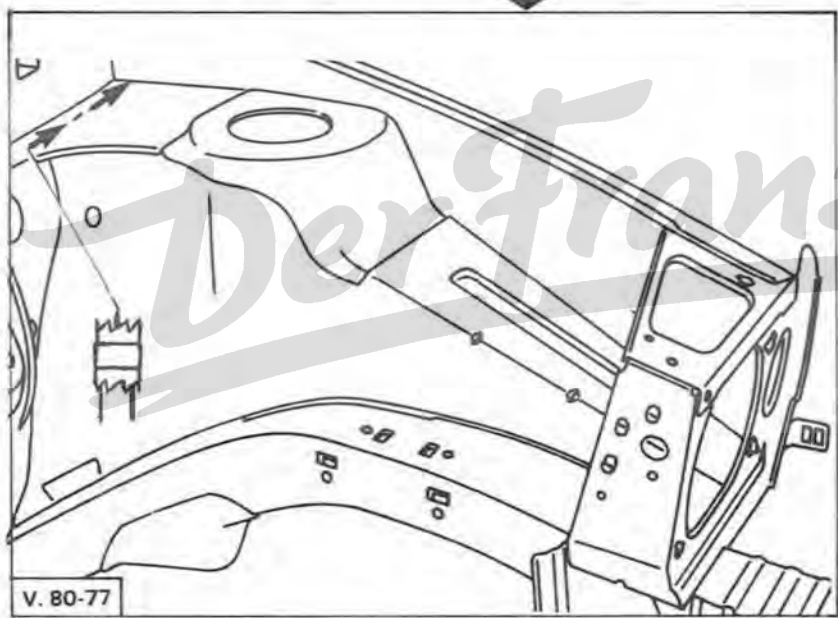
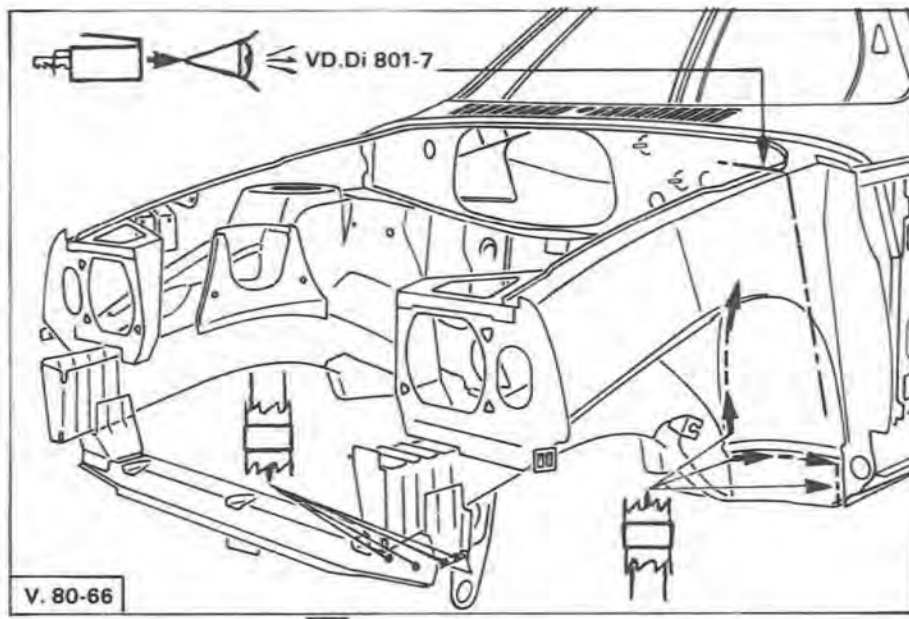

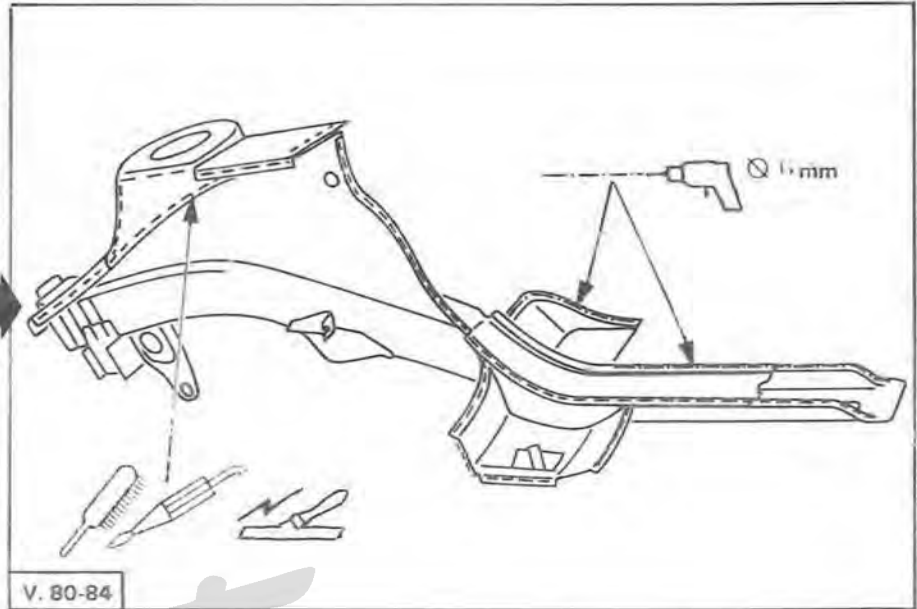
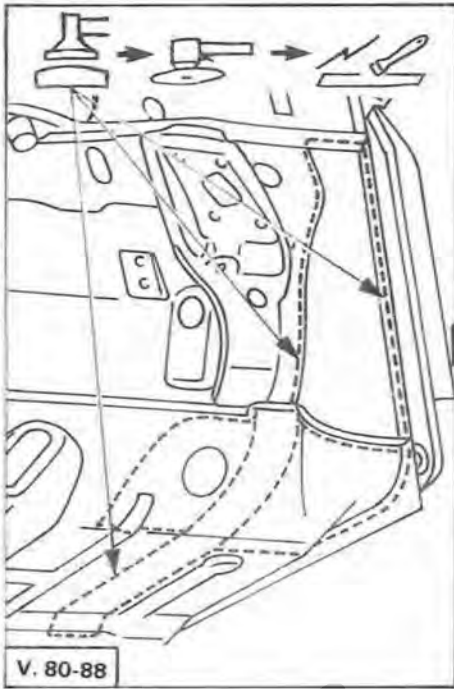
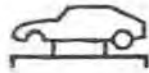

Der Franzose

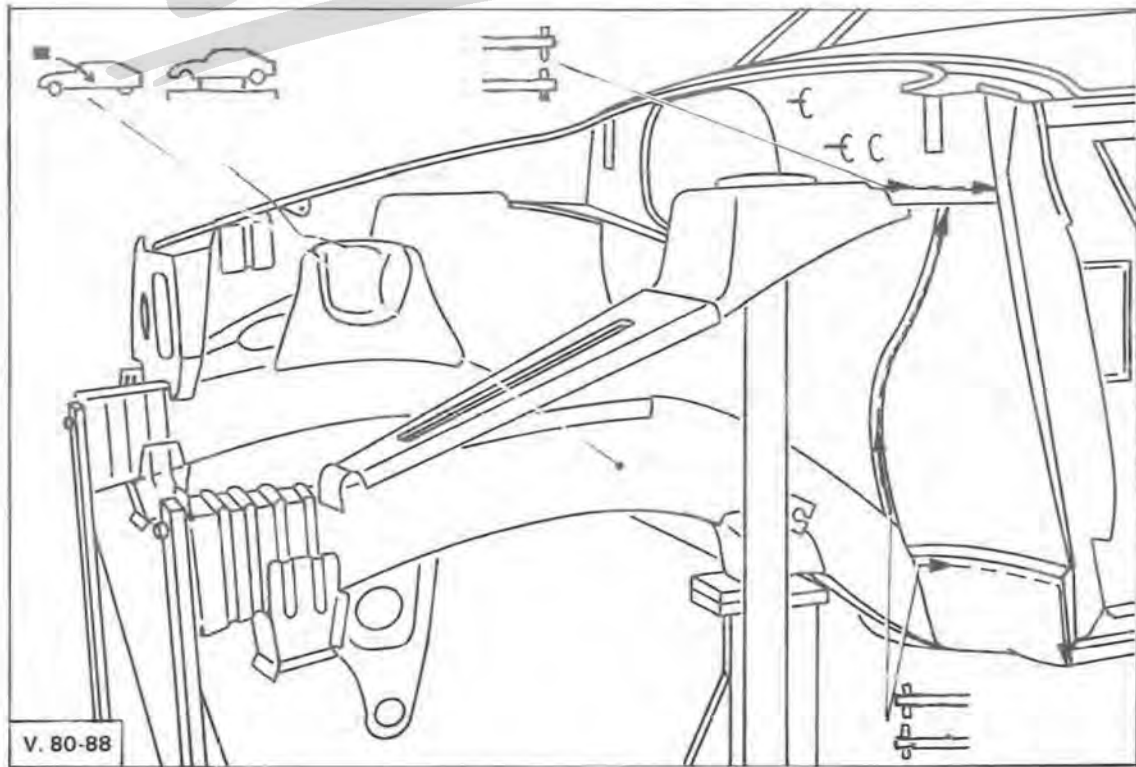

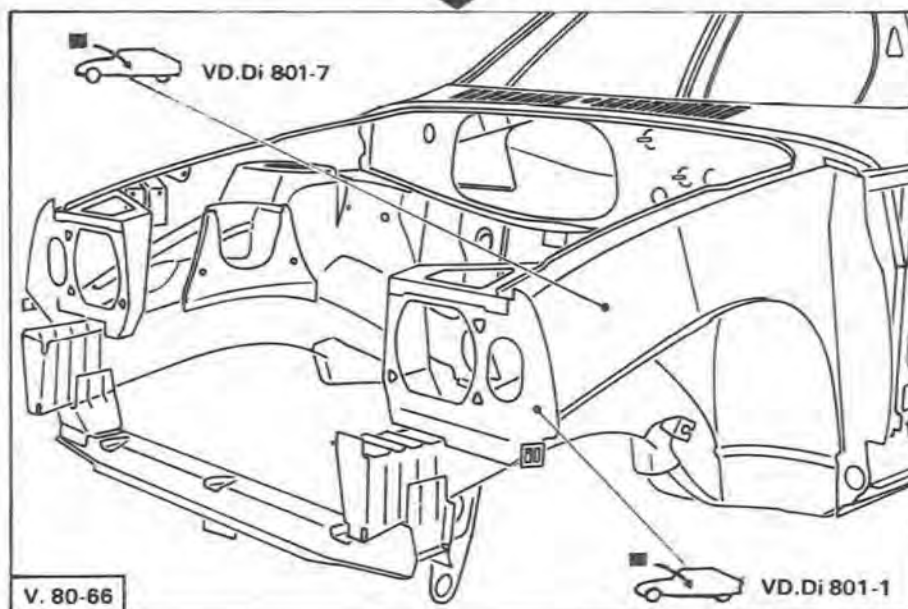
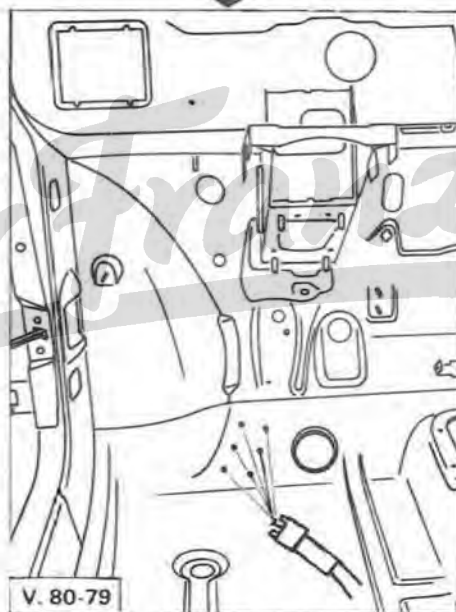
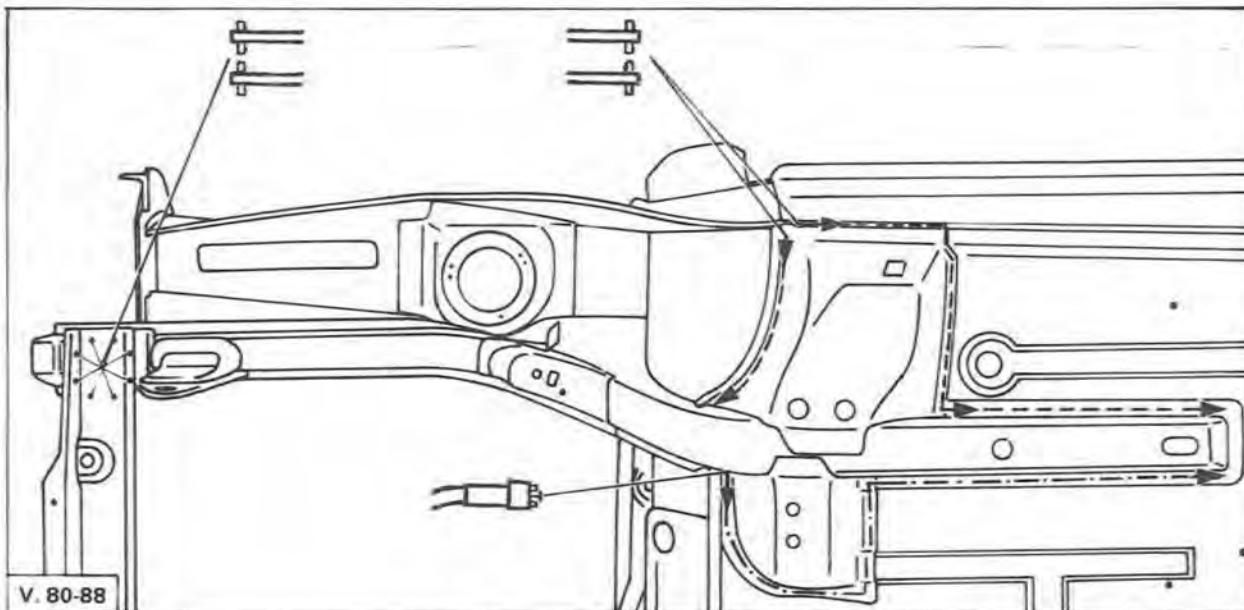

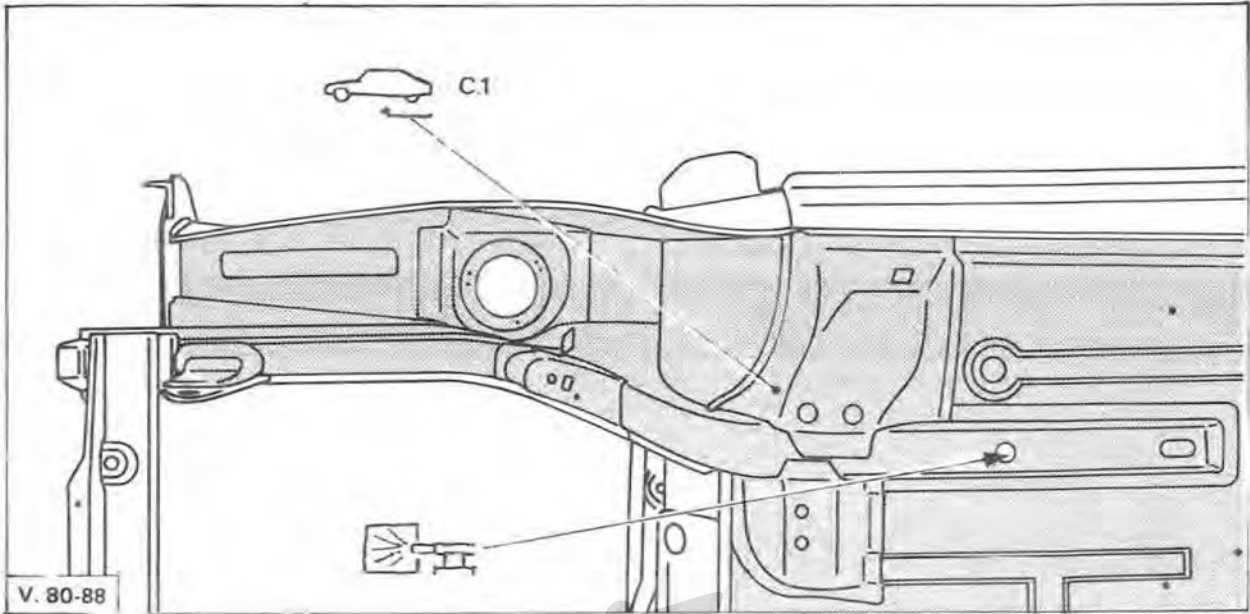
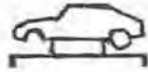

Der Franzose

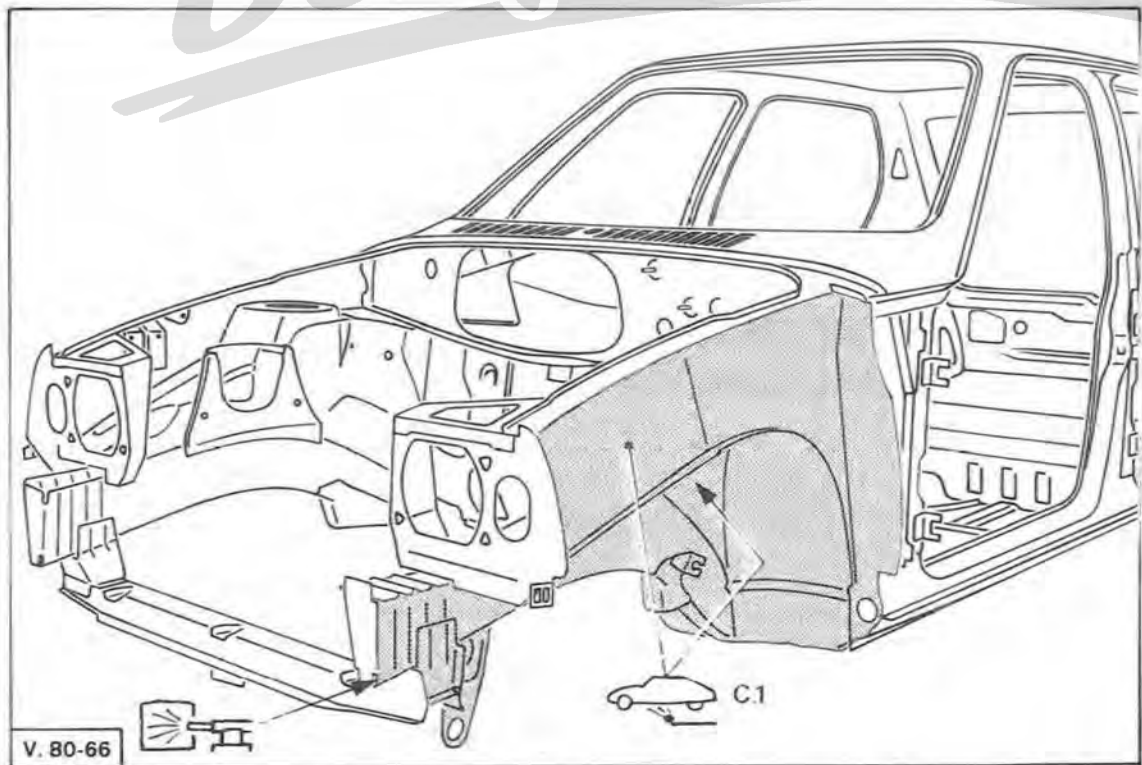

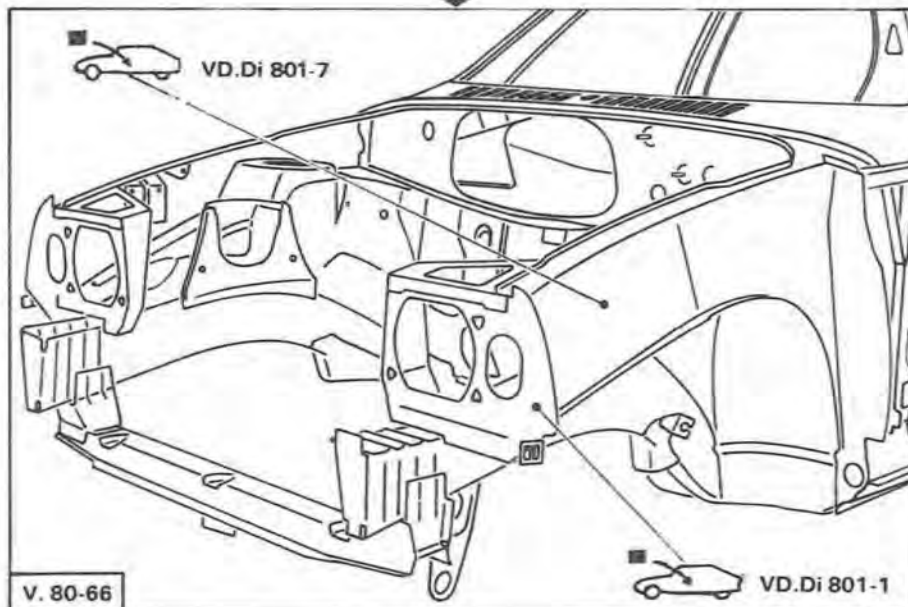
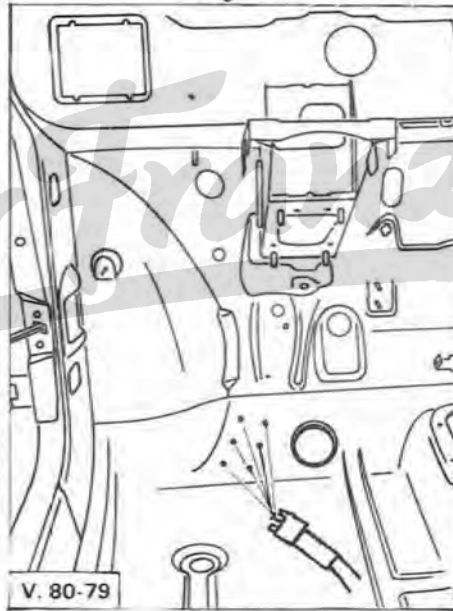
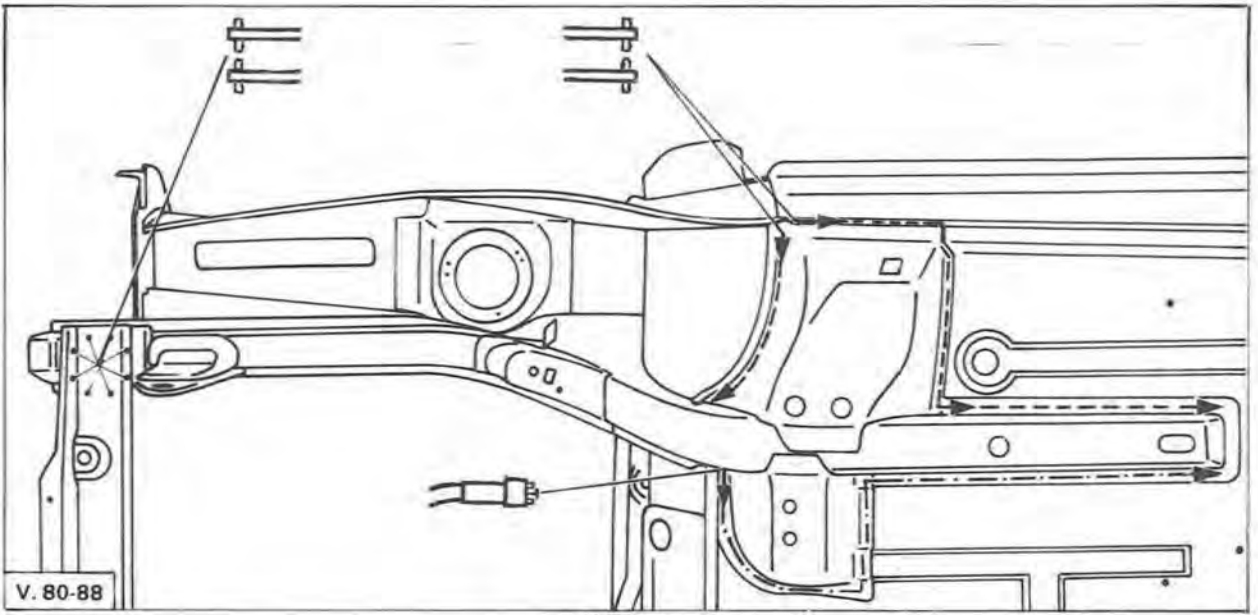
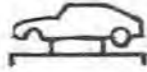

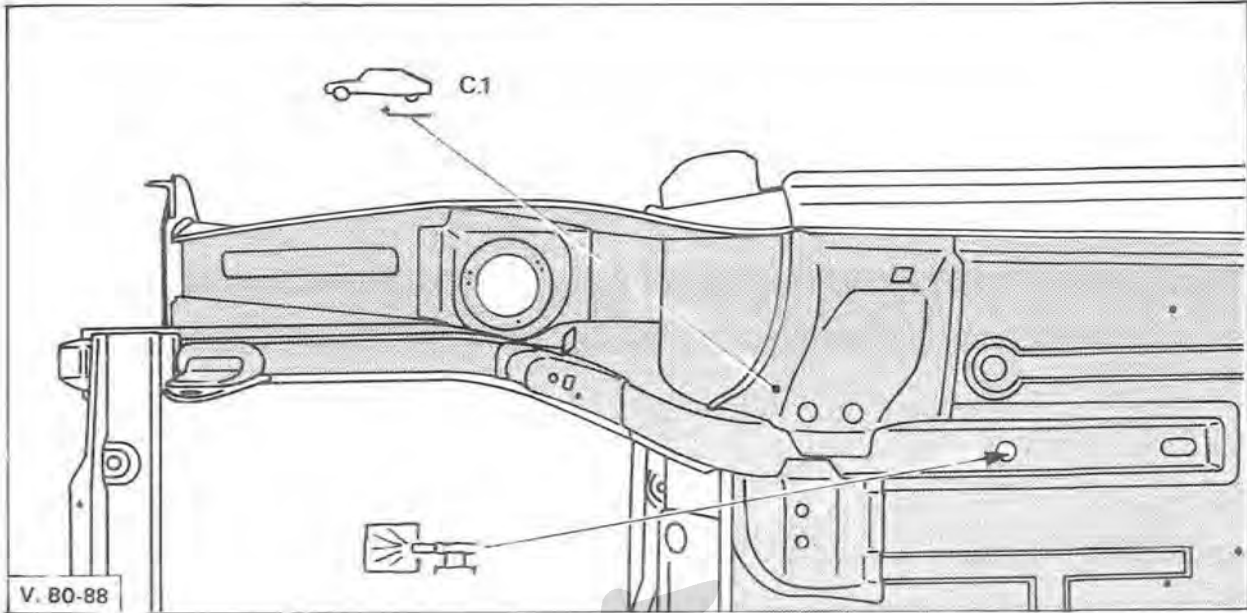

Der Franzose

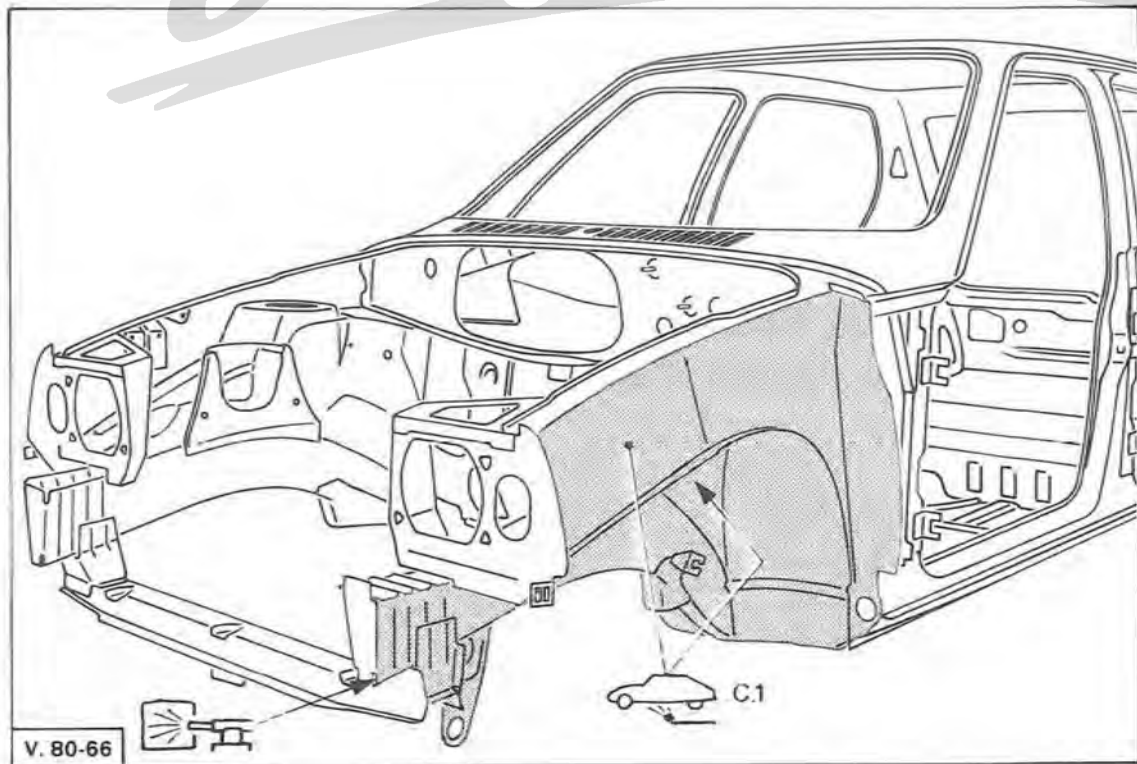

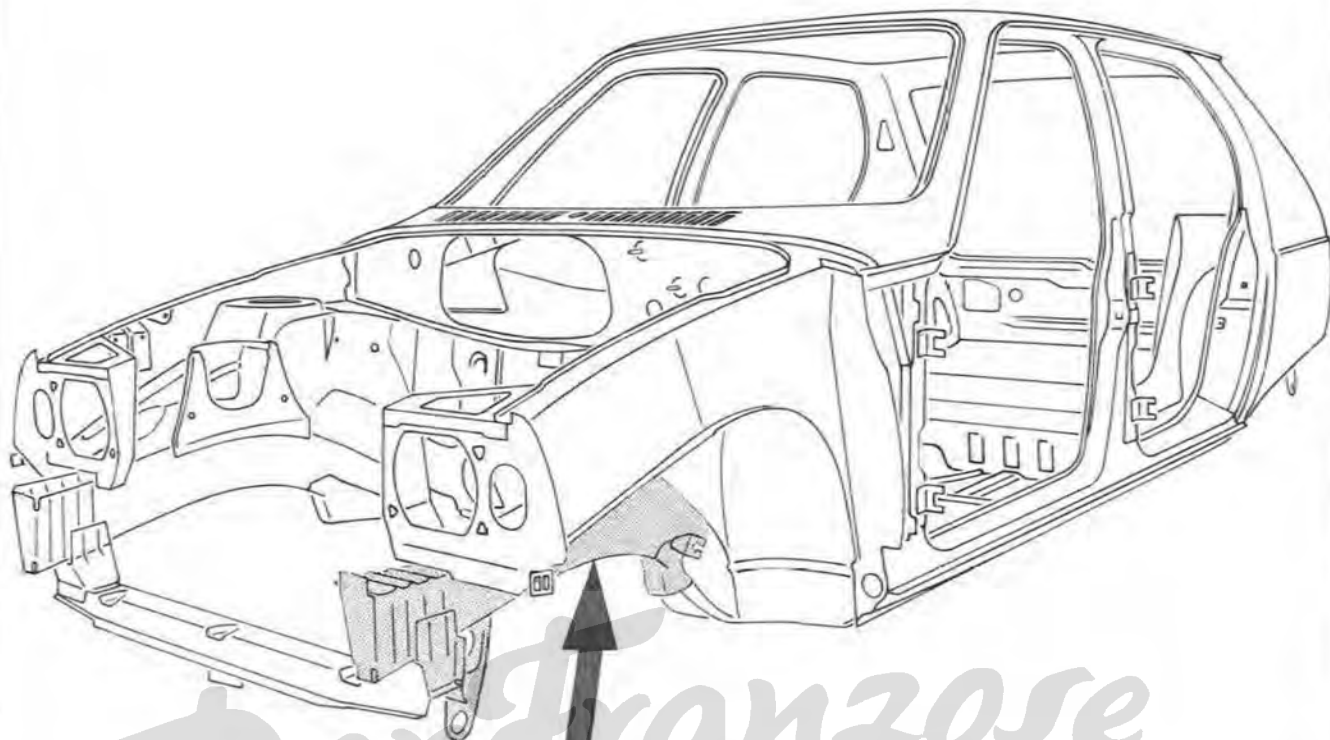

V 80-66

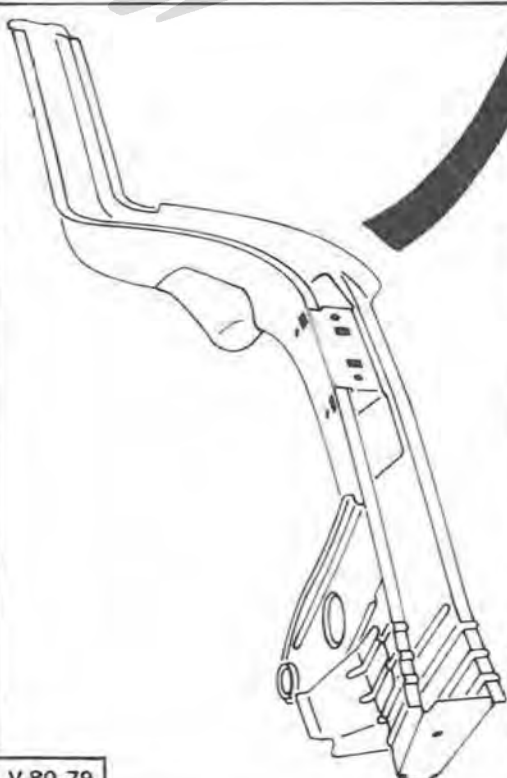

V 80-79



G. 94 56 500 246
D. 94 56 500 245

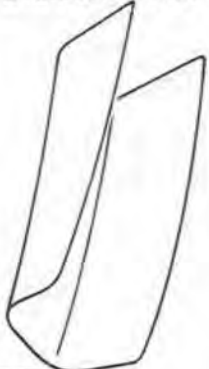

V 80-68

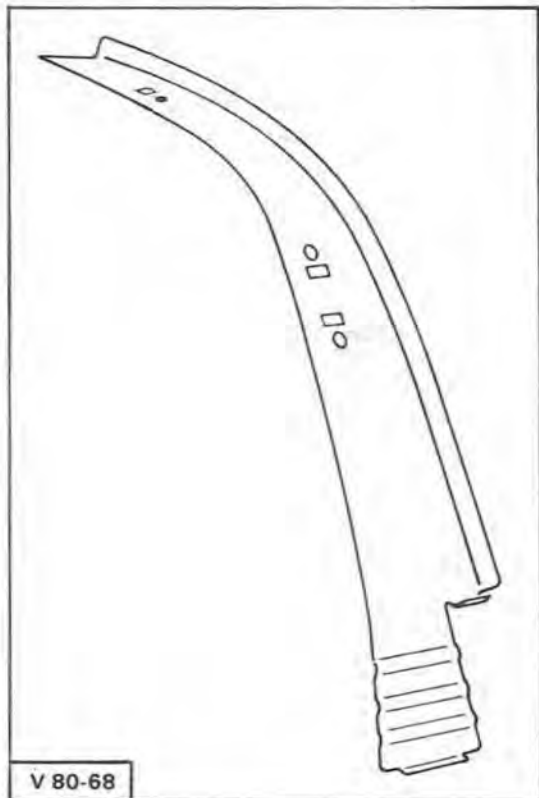

V 80-68

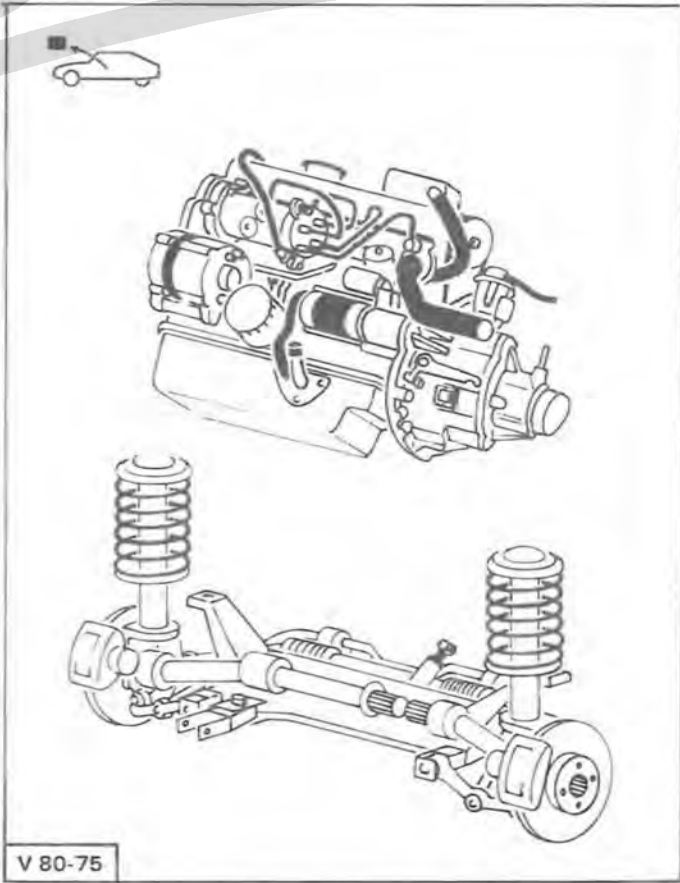
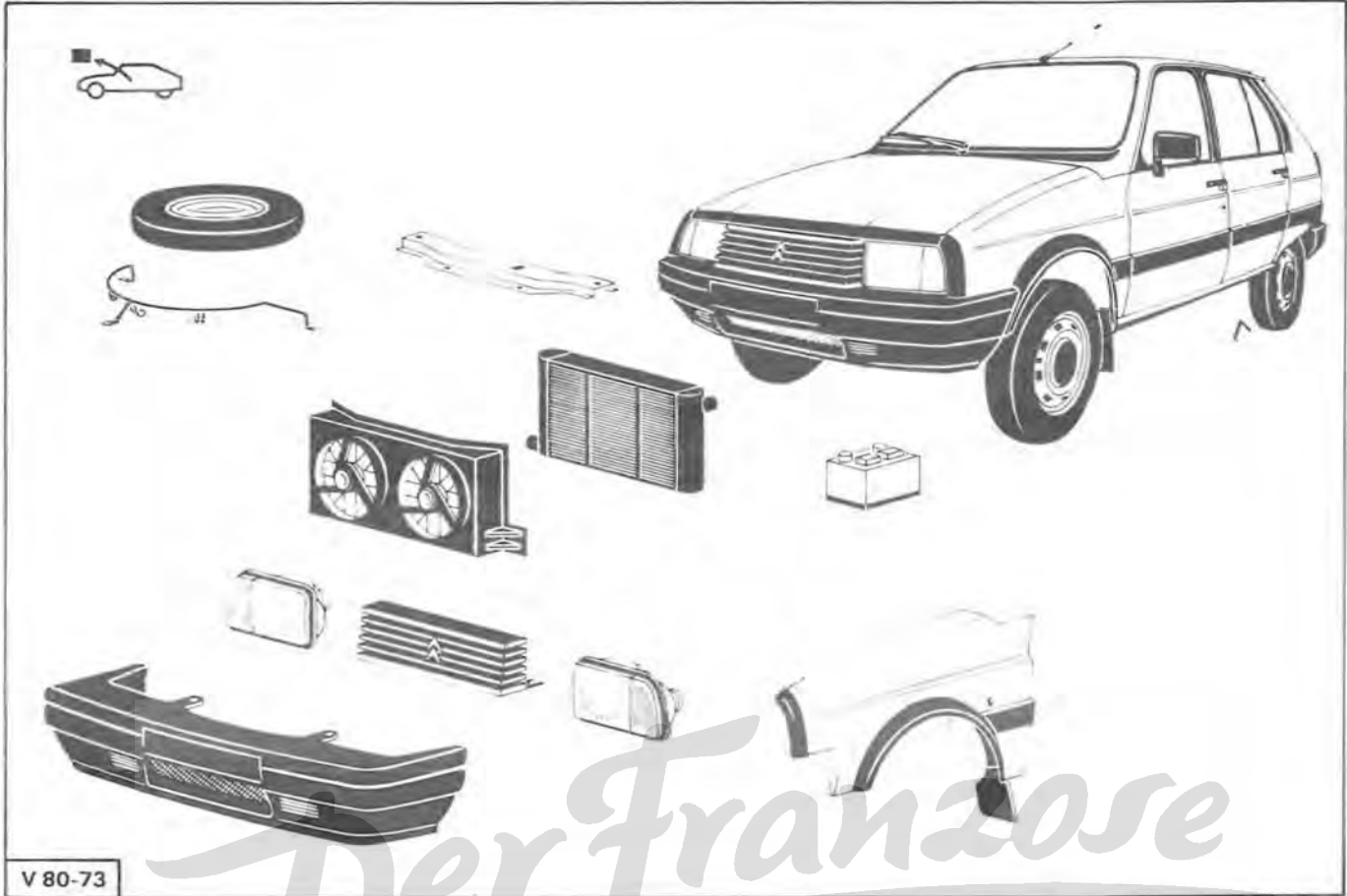
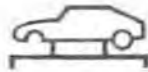

Der Franzose

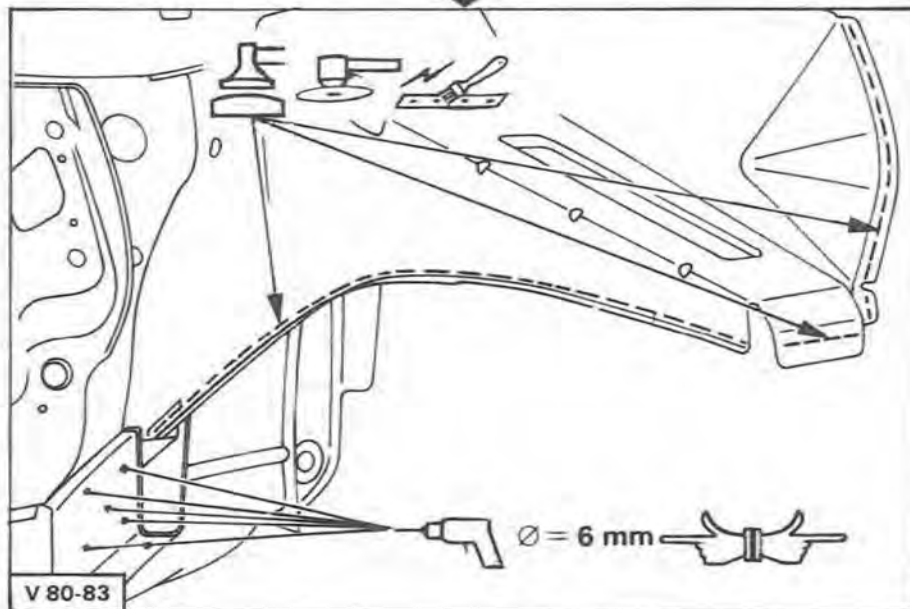
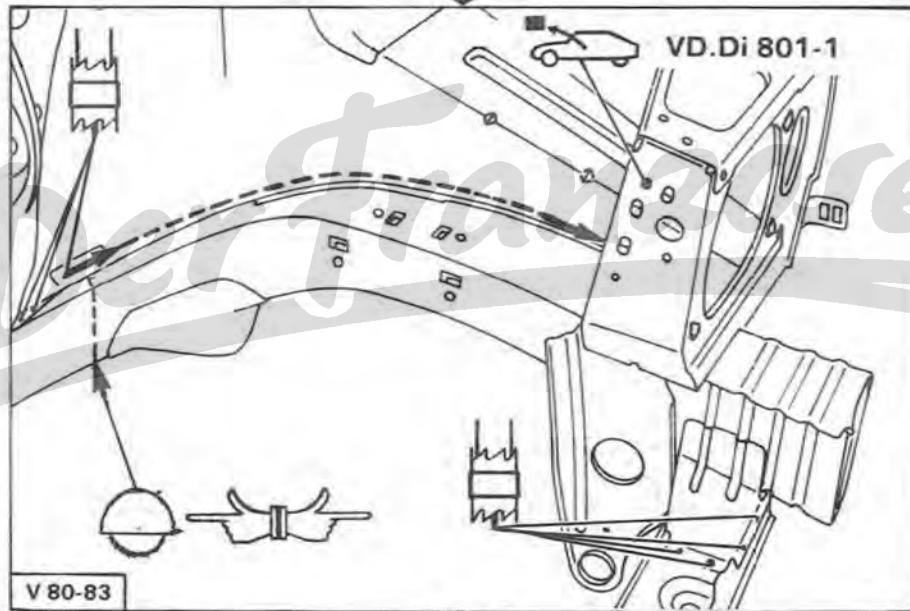
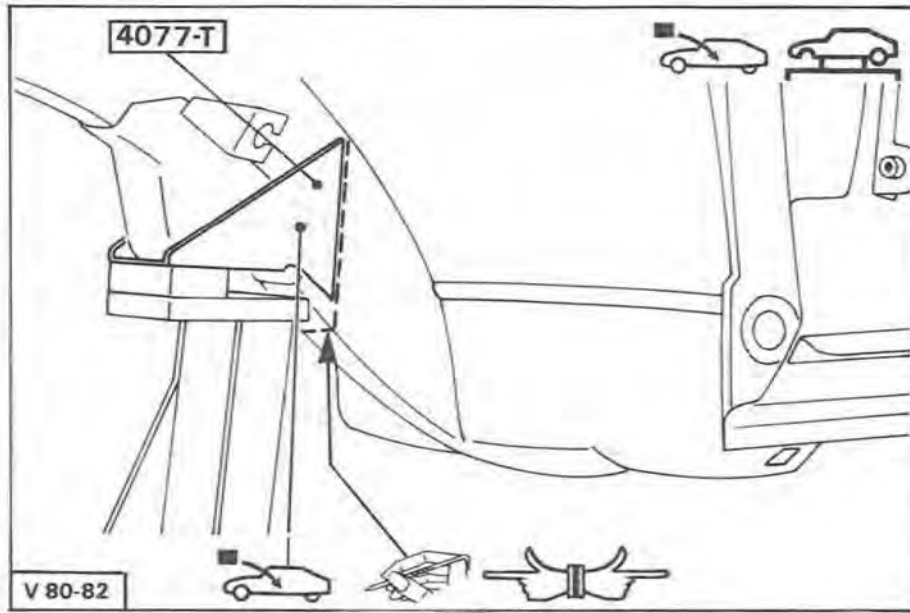

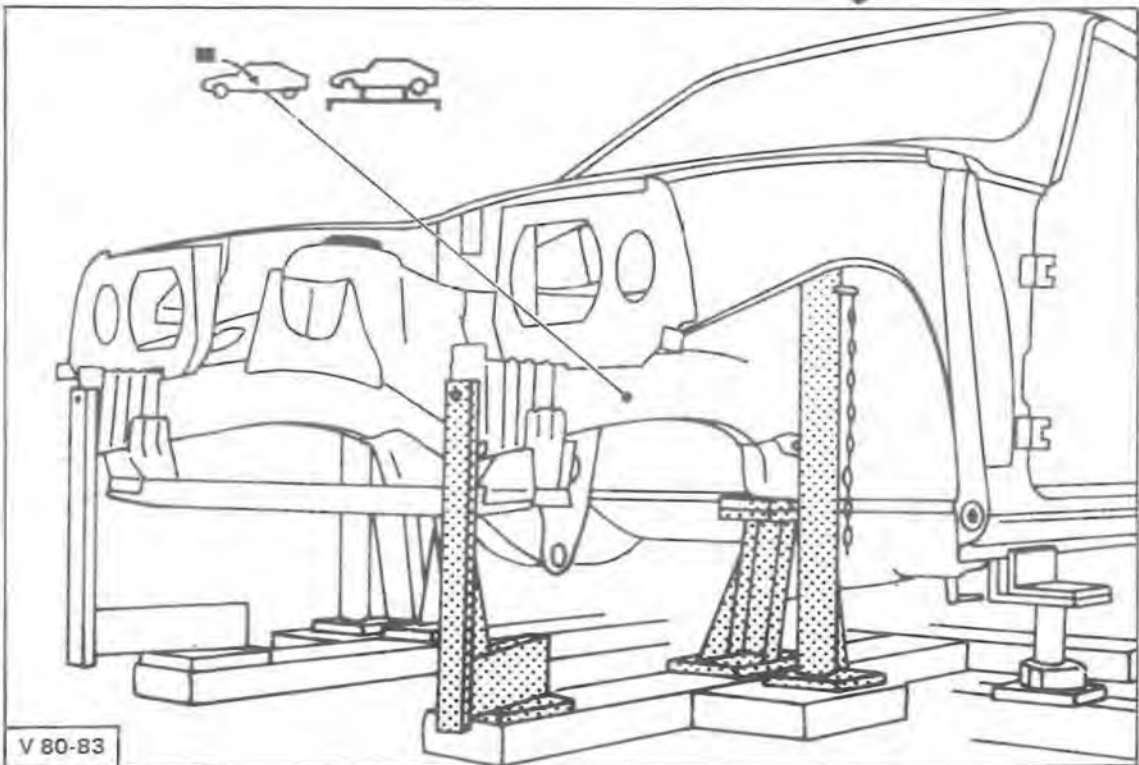
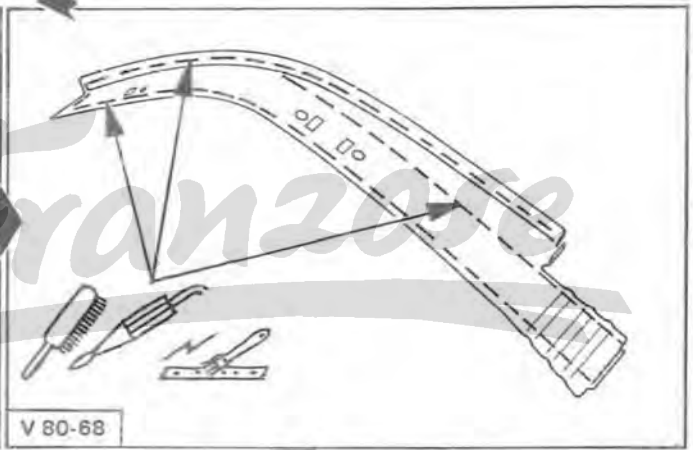
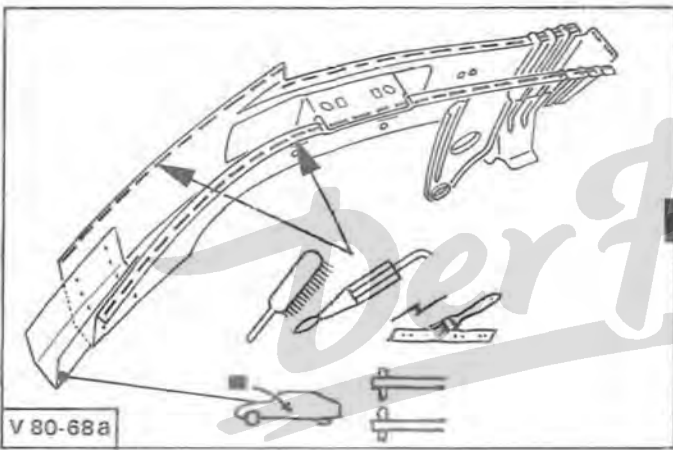
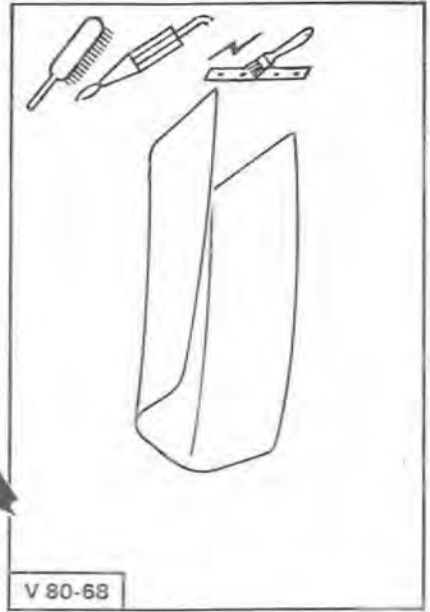
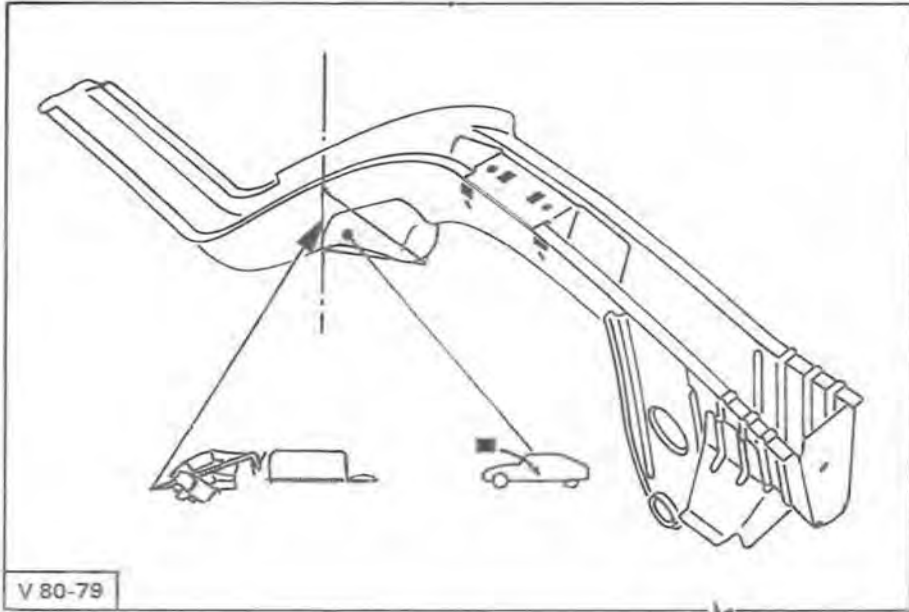

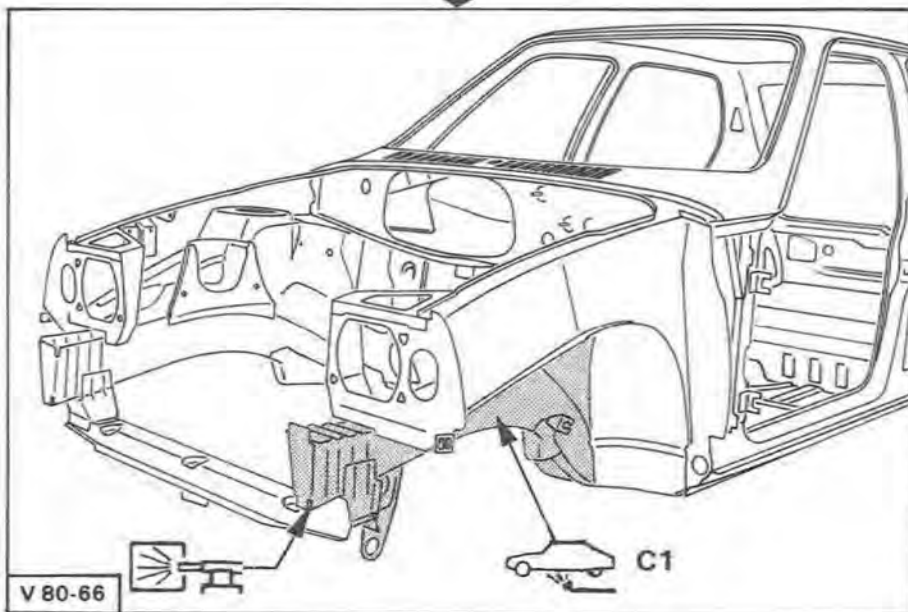
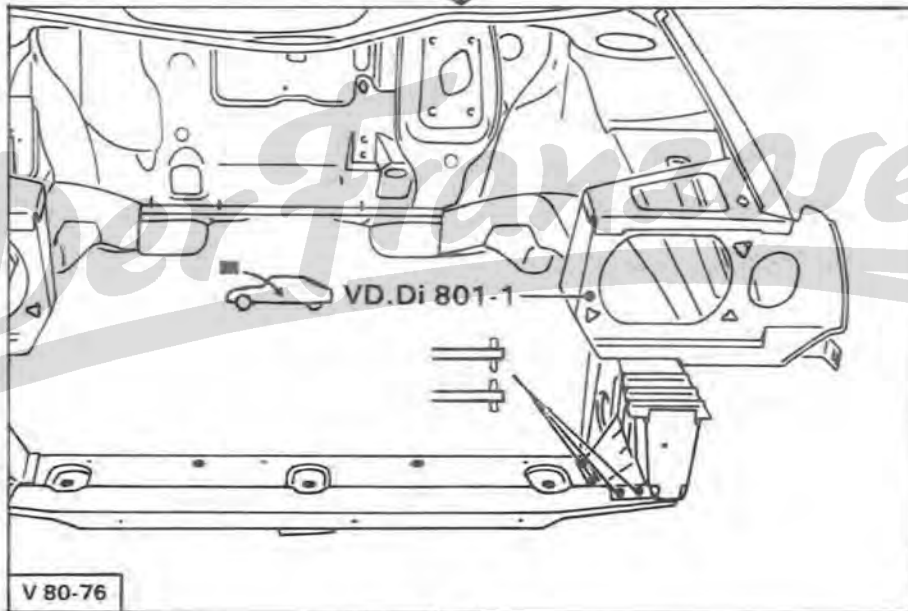
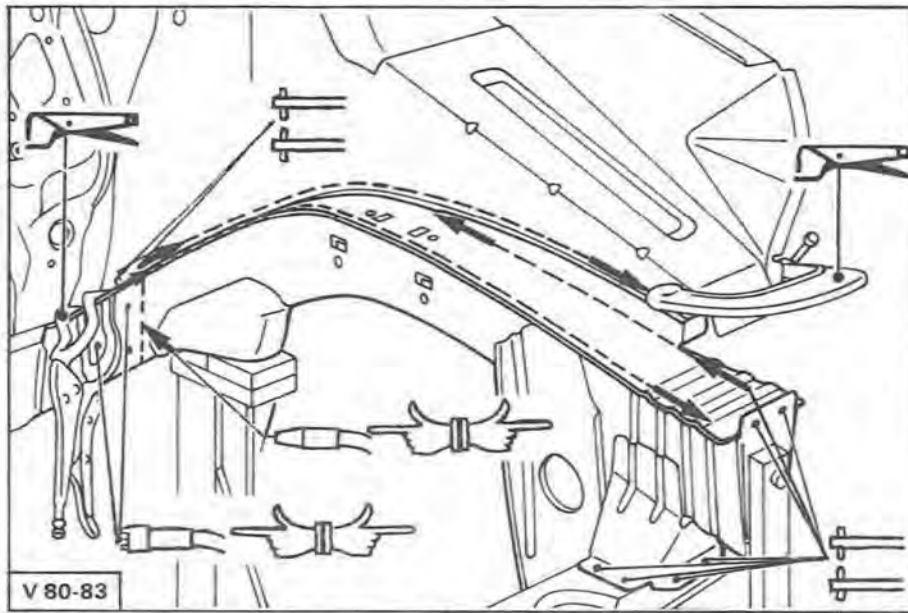

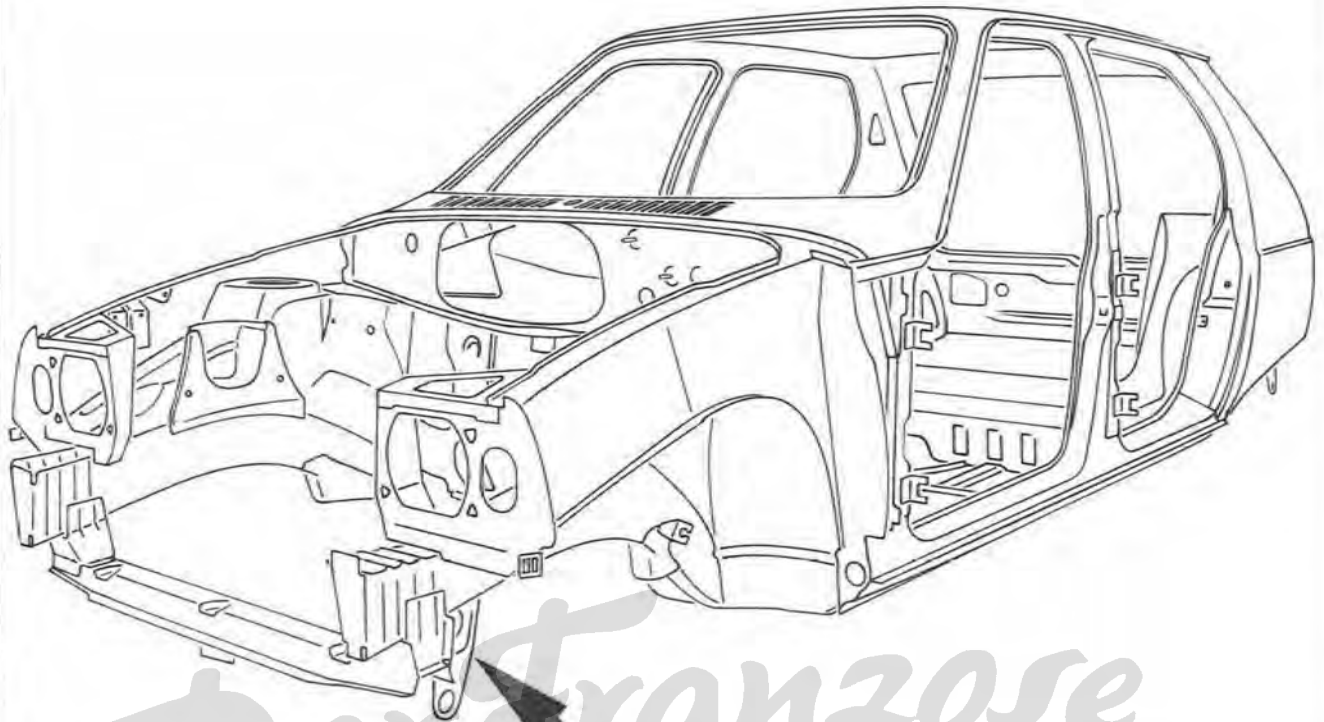

V 80-66

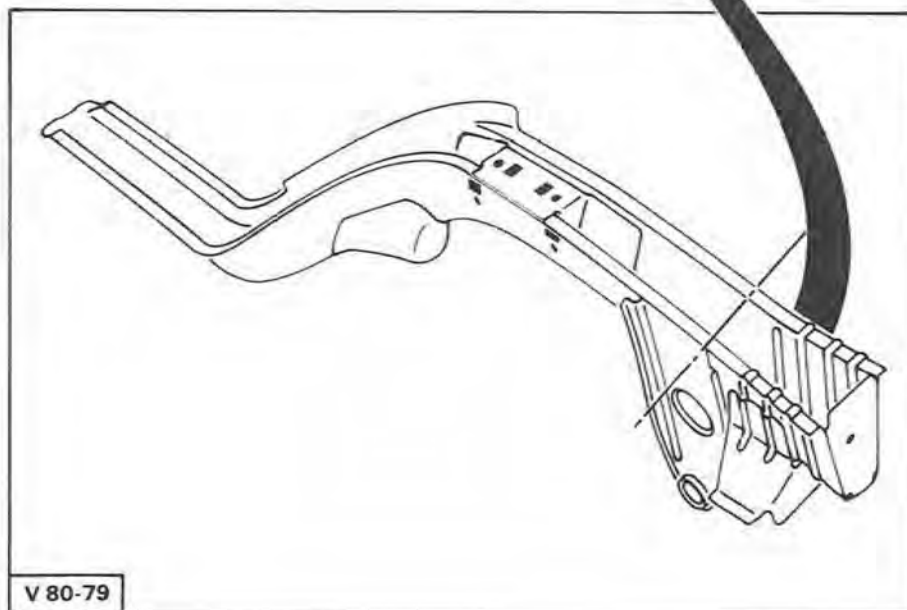

V 80-79

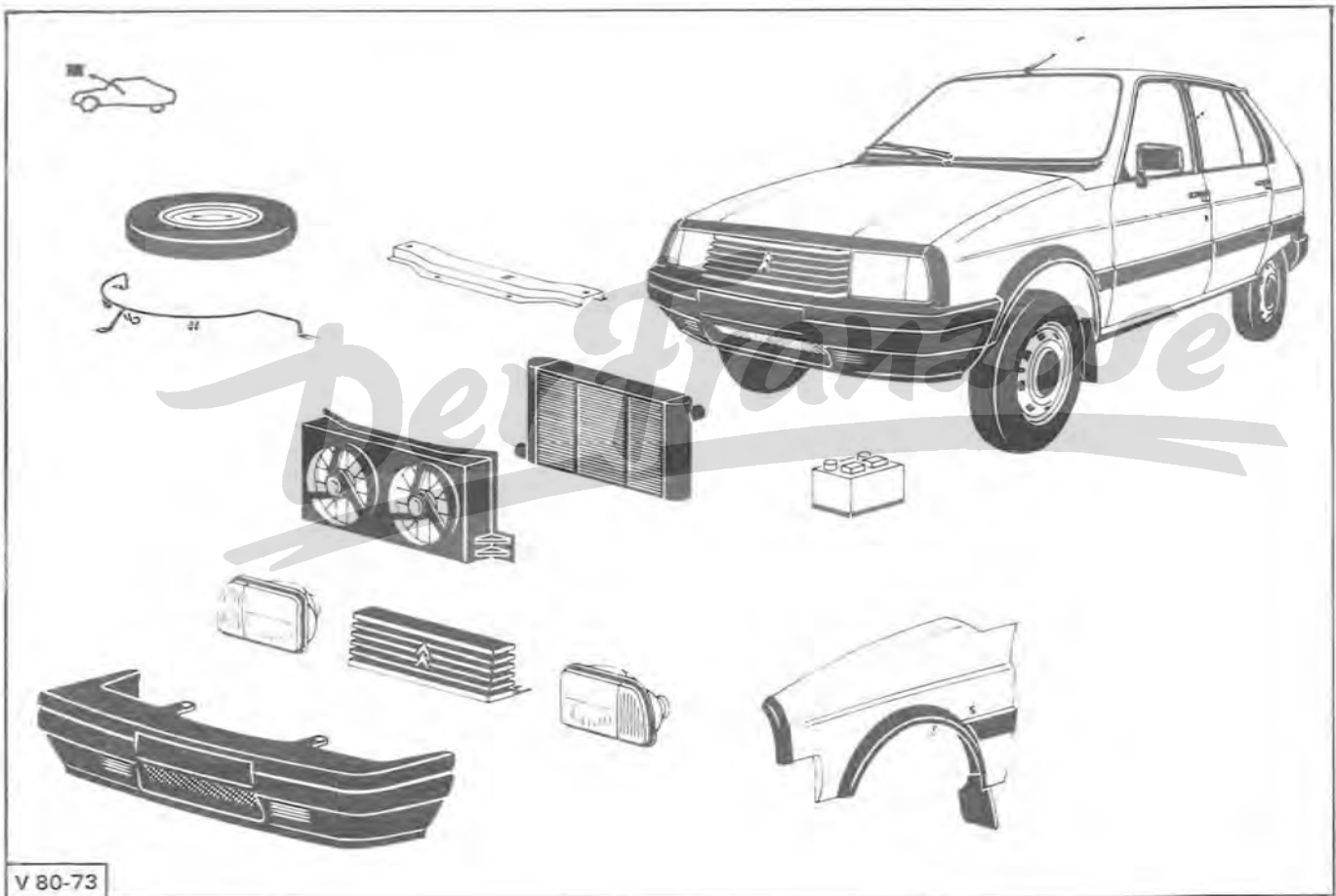

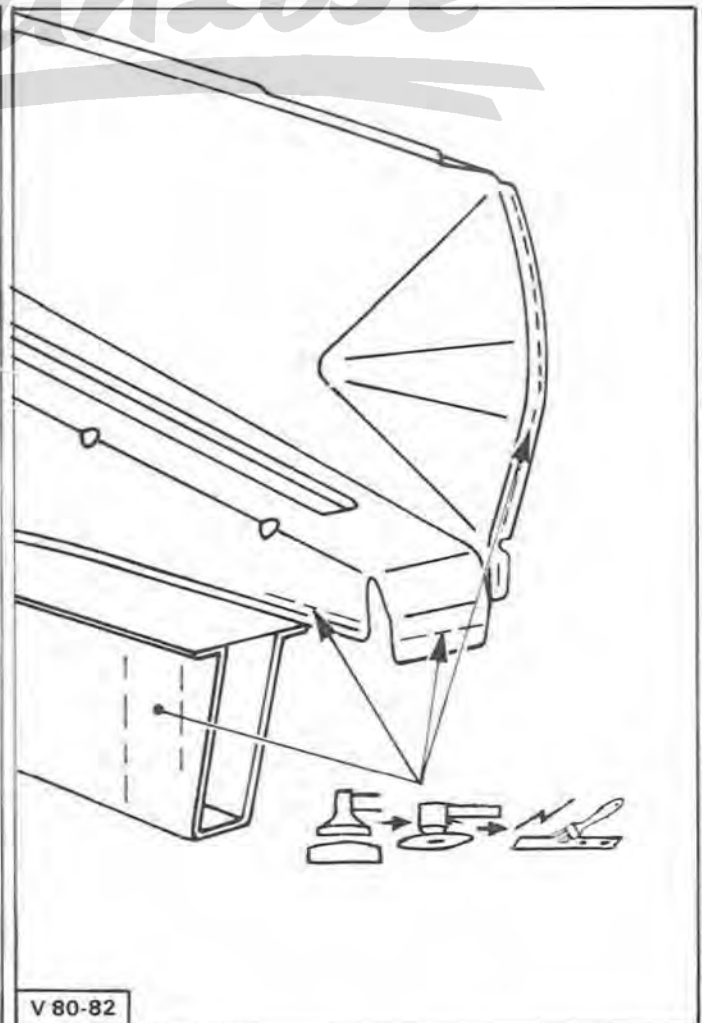
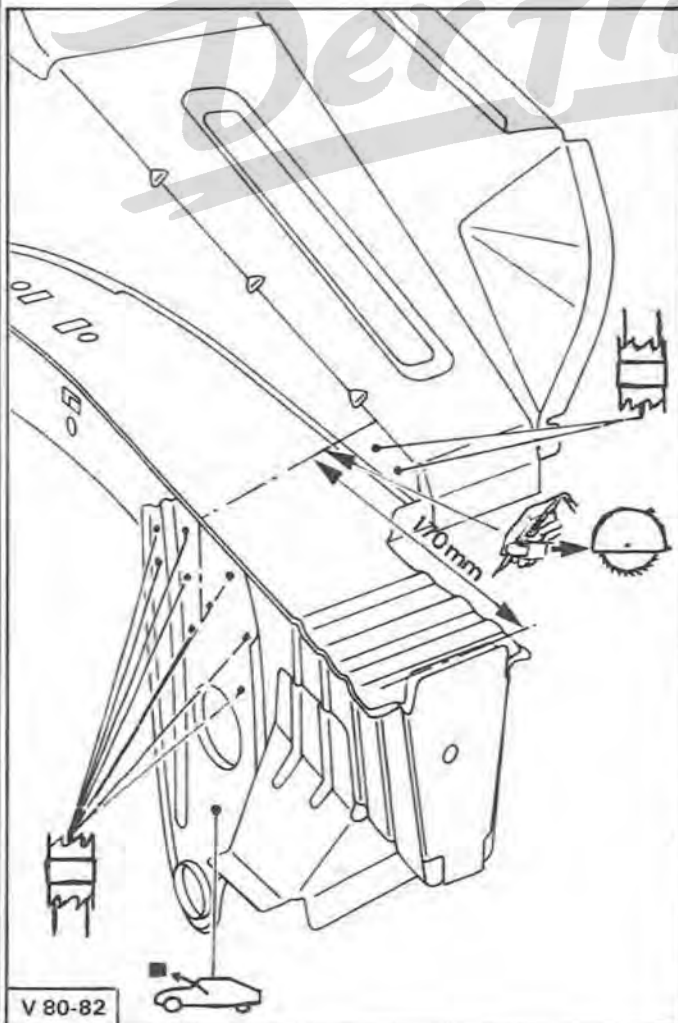
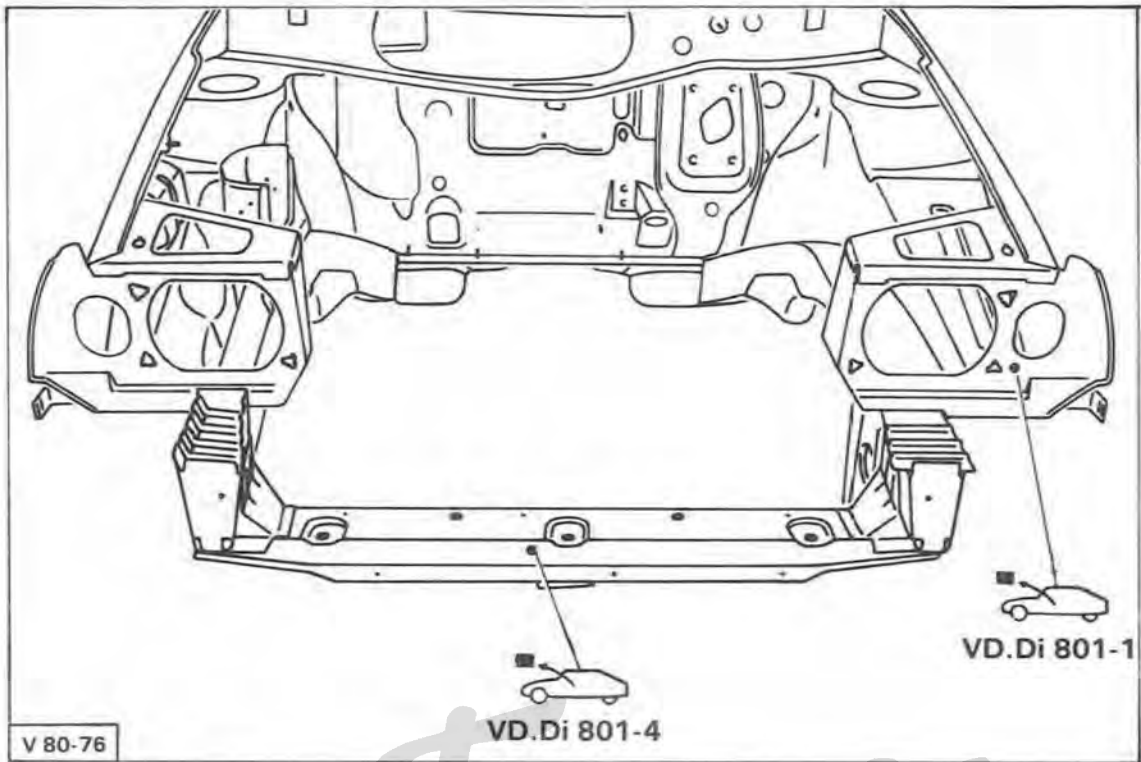

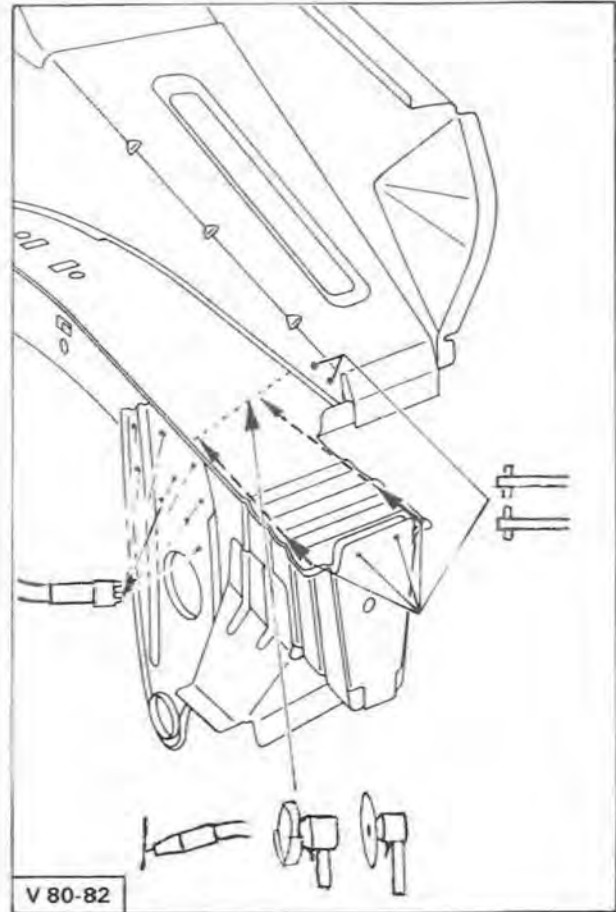
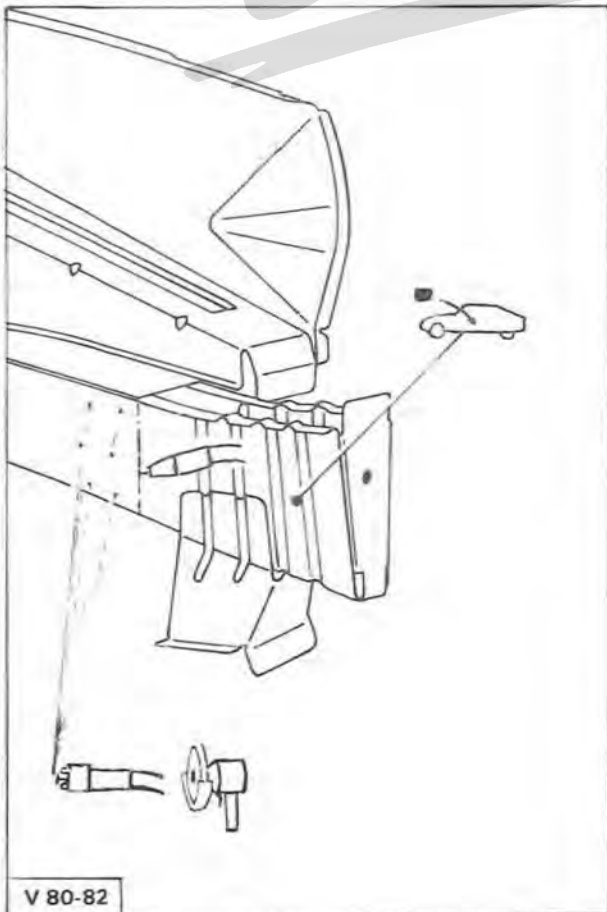
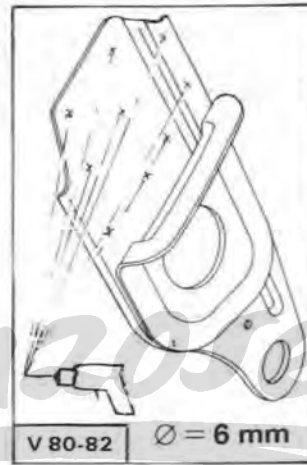
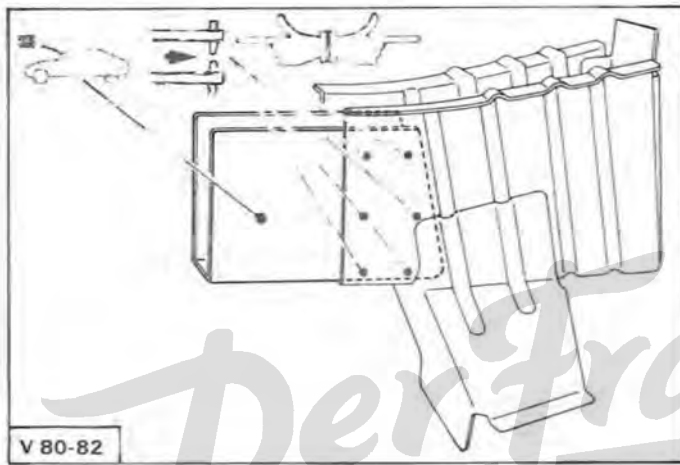
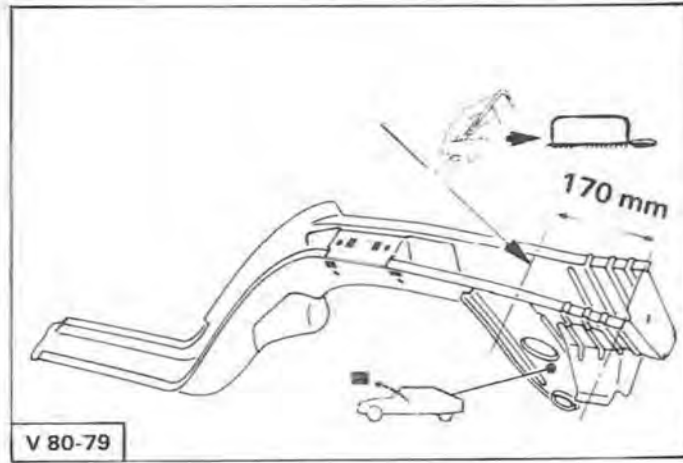
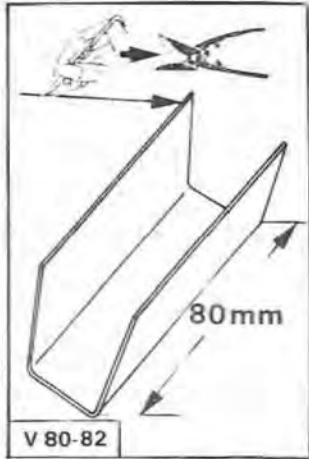

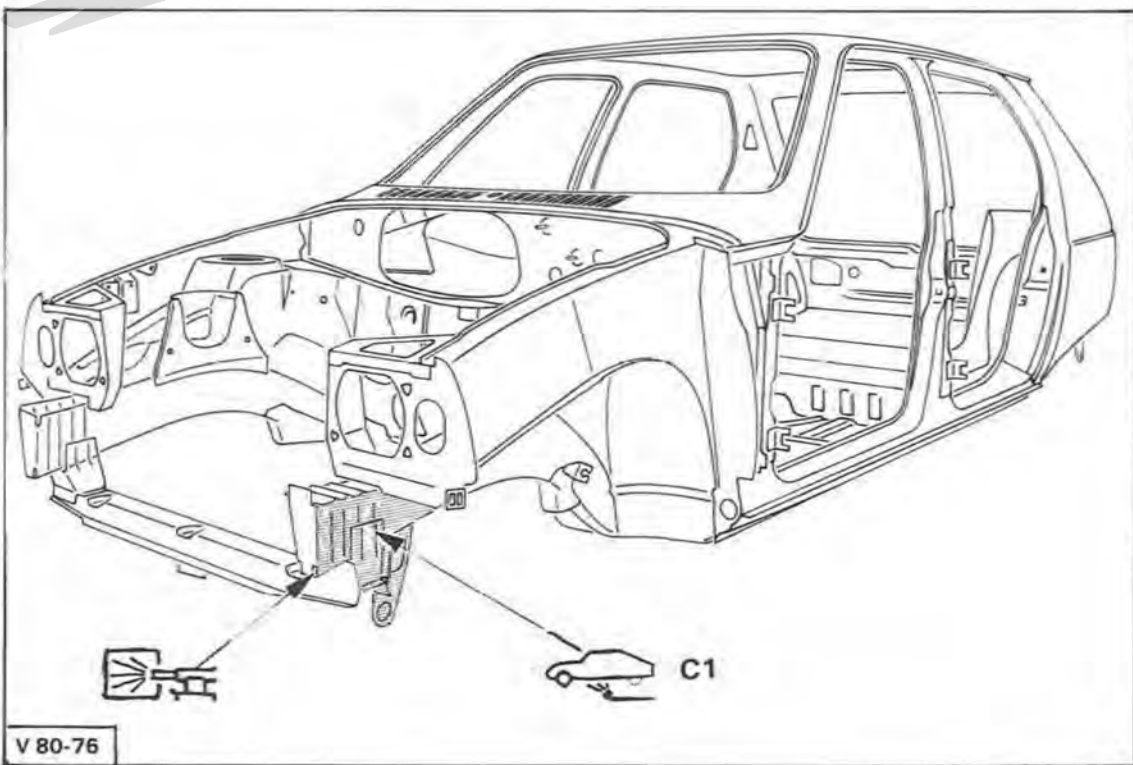
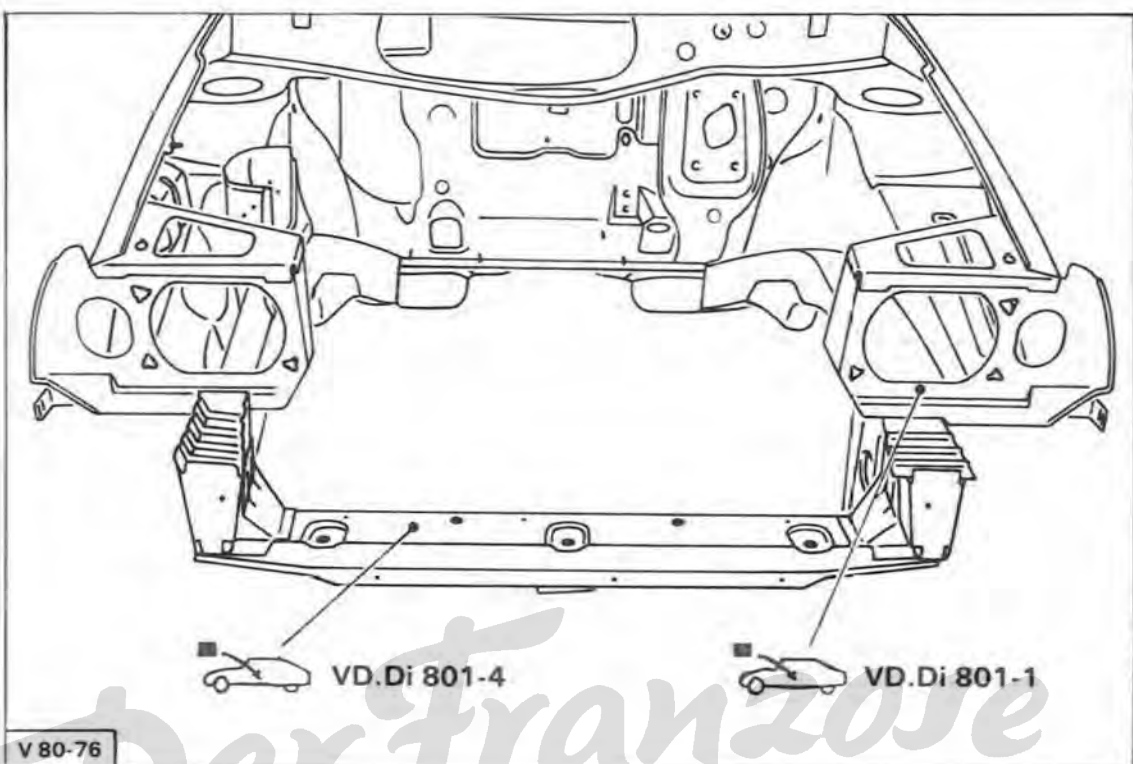

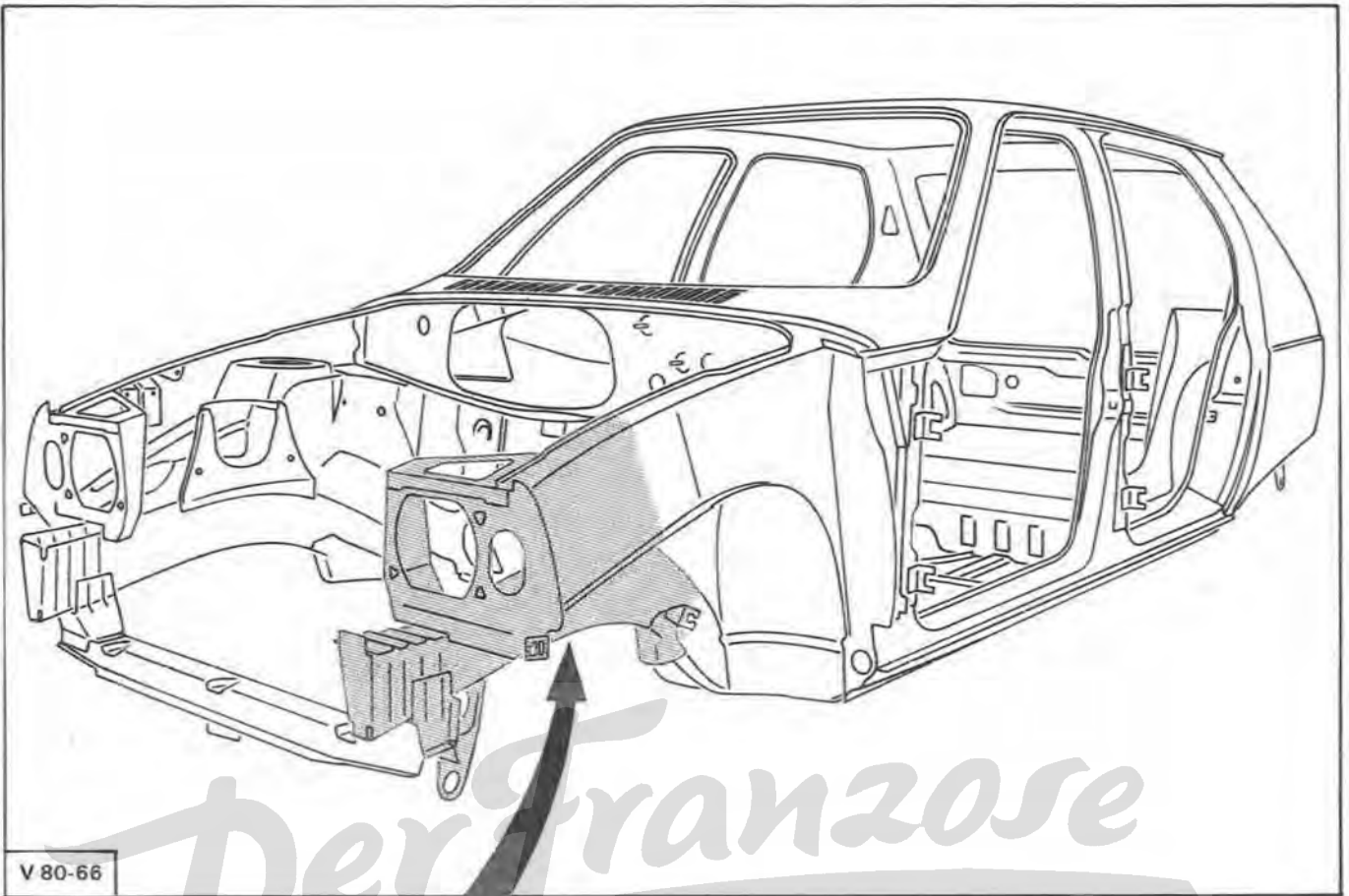

V 80-66

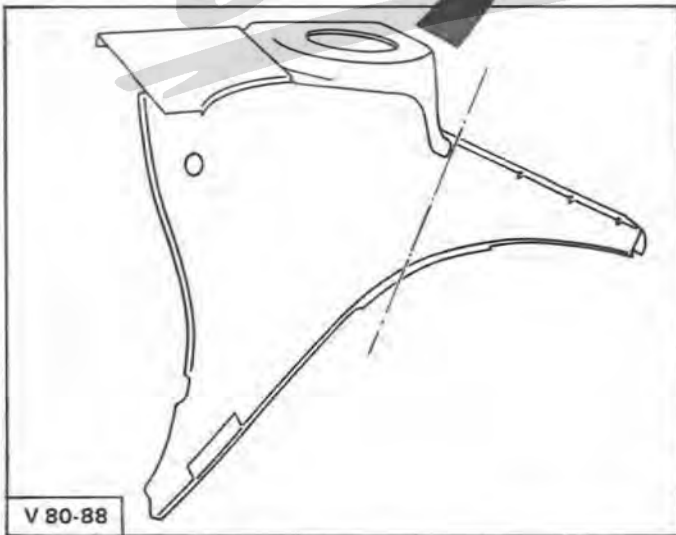

V 80-88

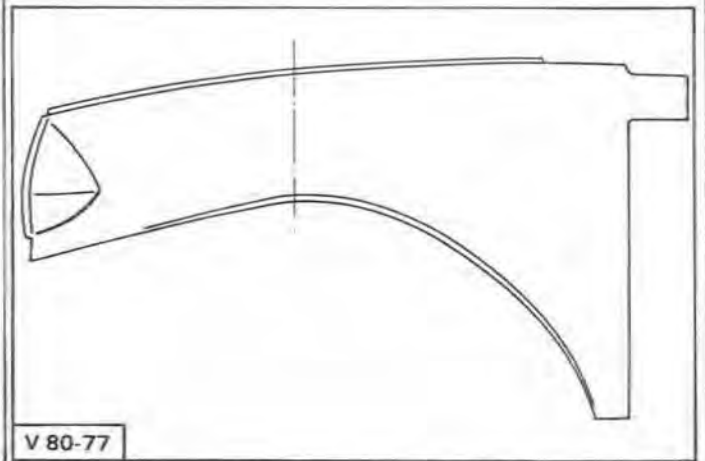

V 80-77

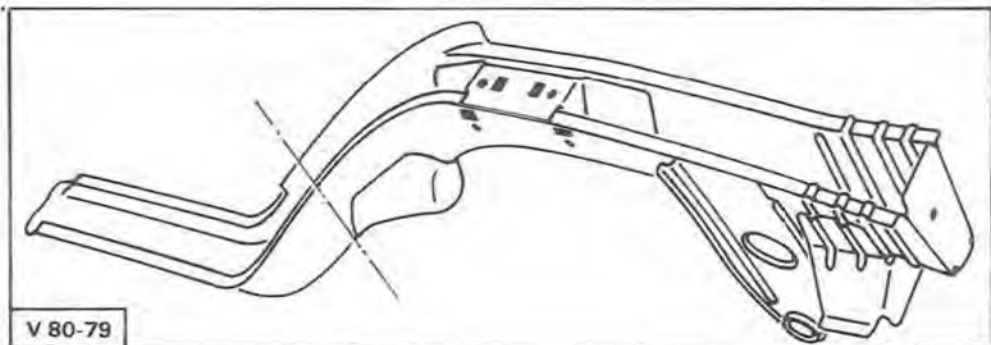

V 80-79

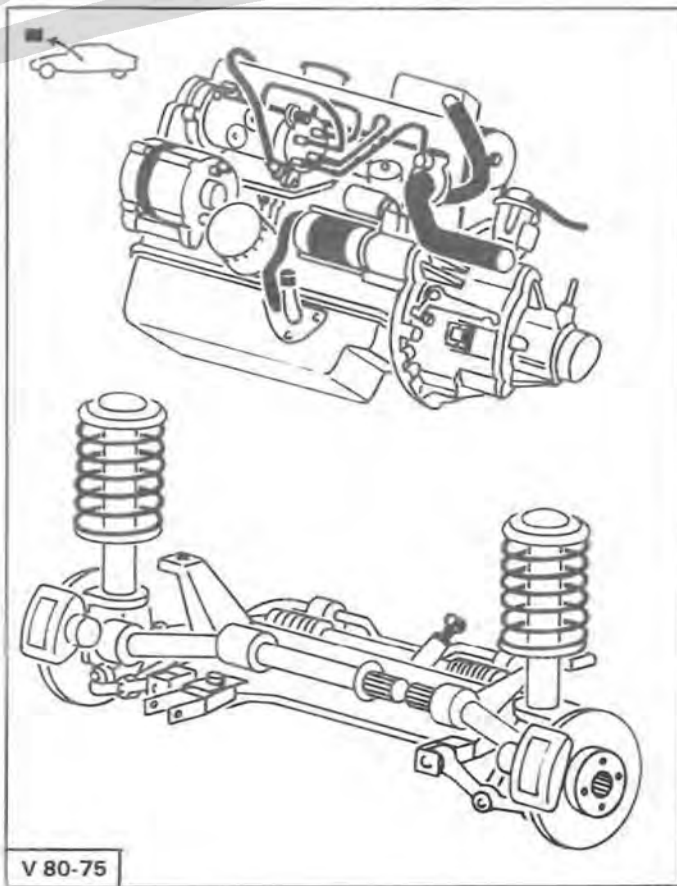
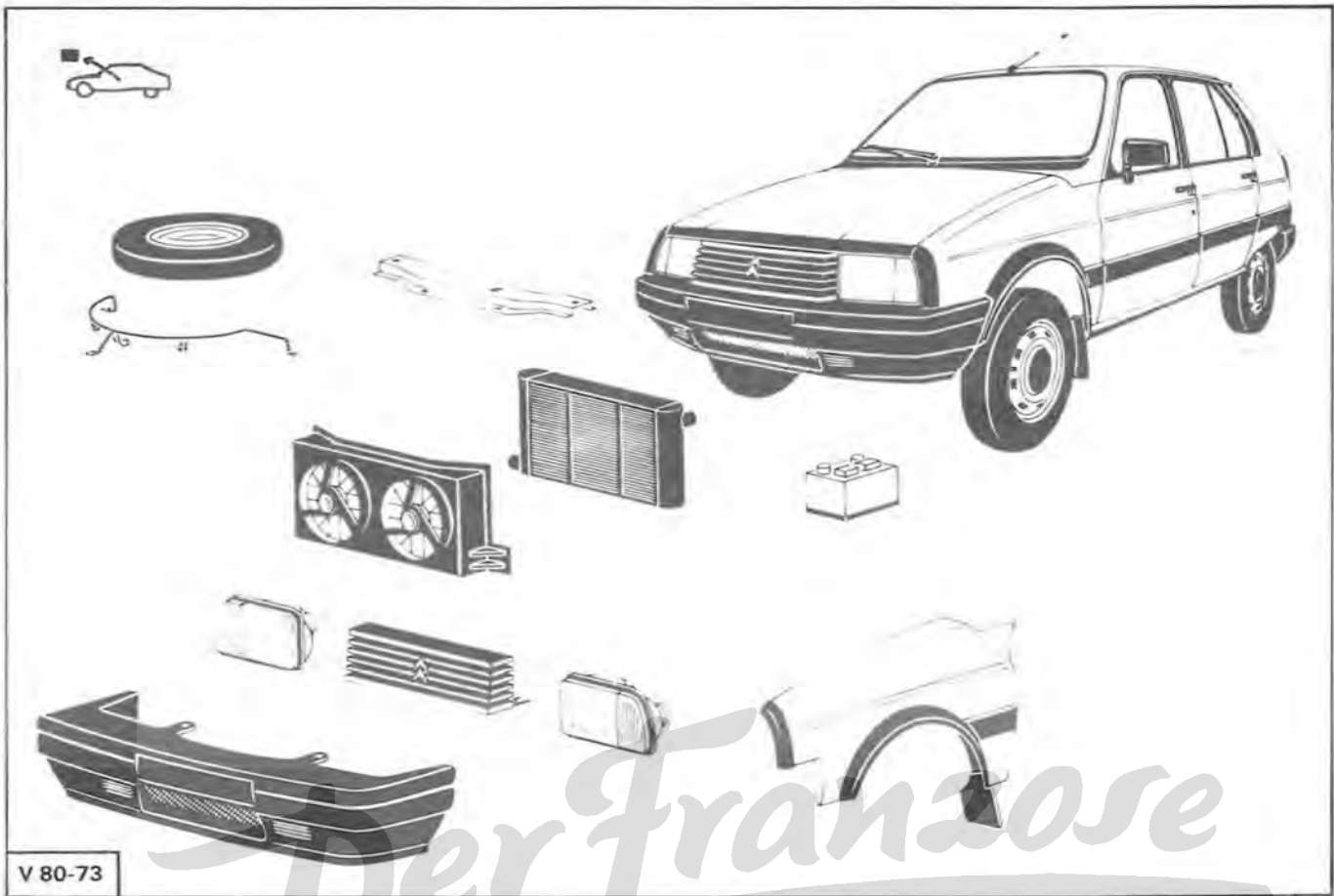

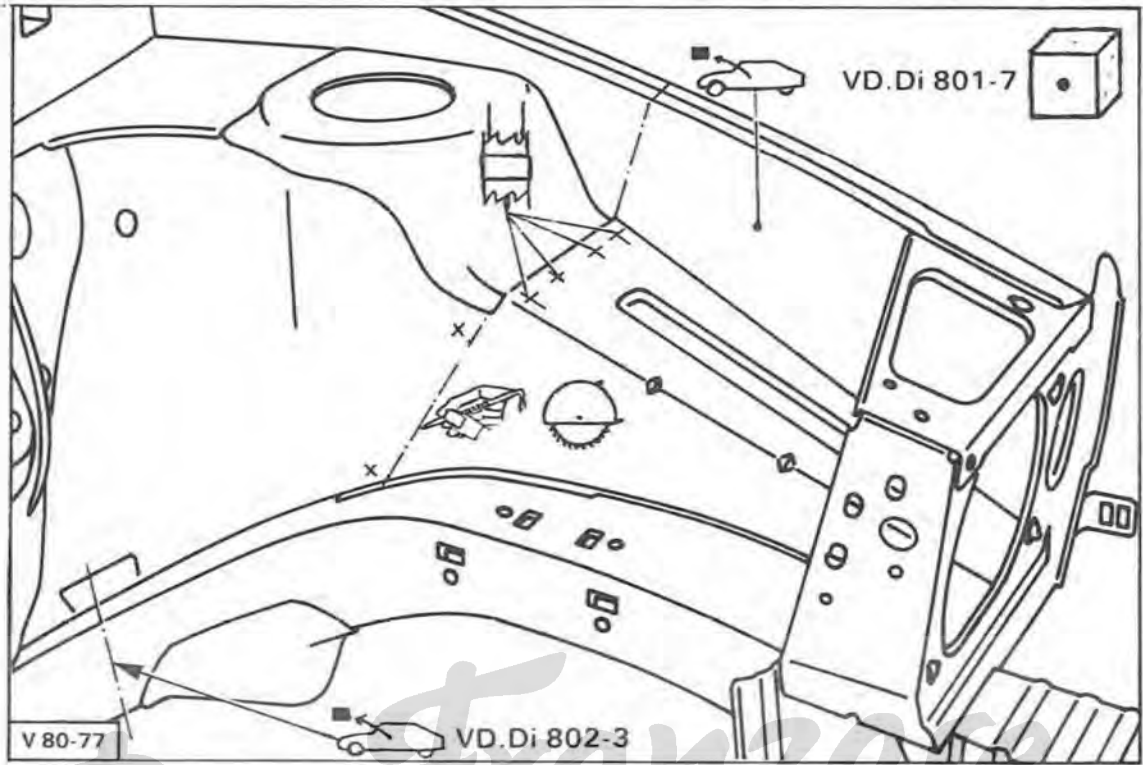

Der Franzose

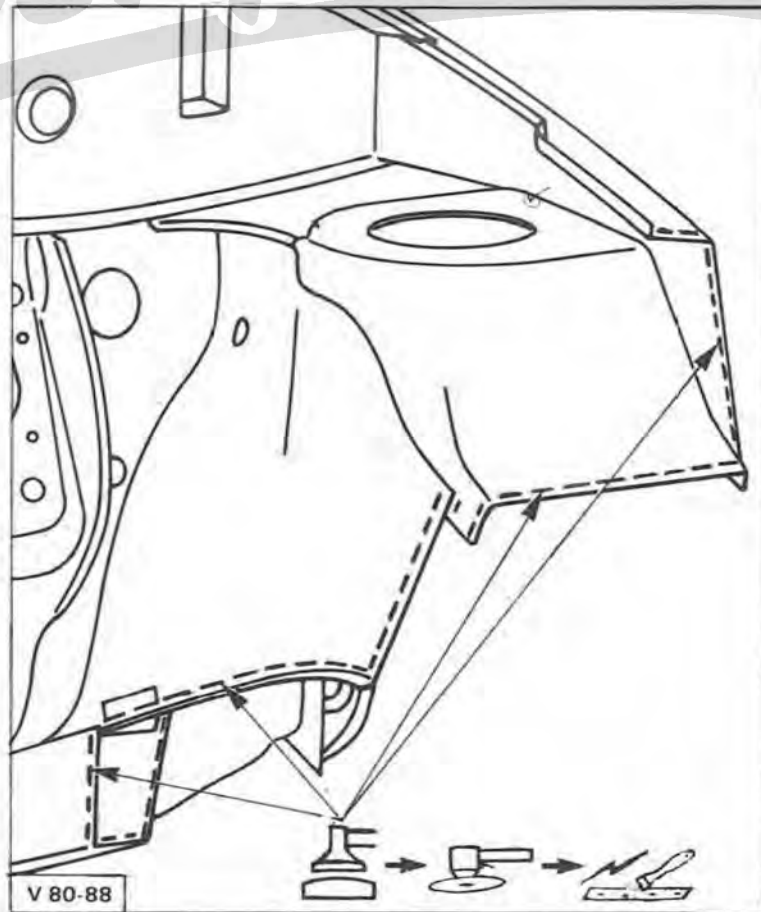

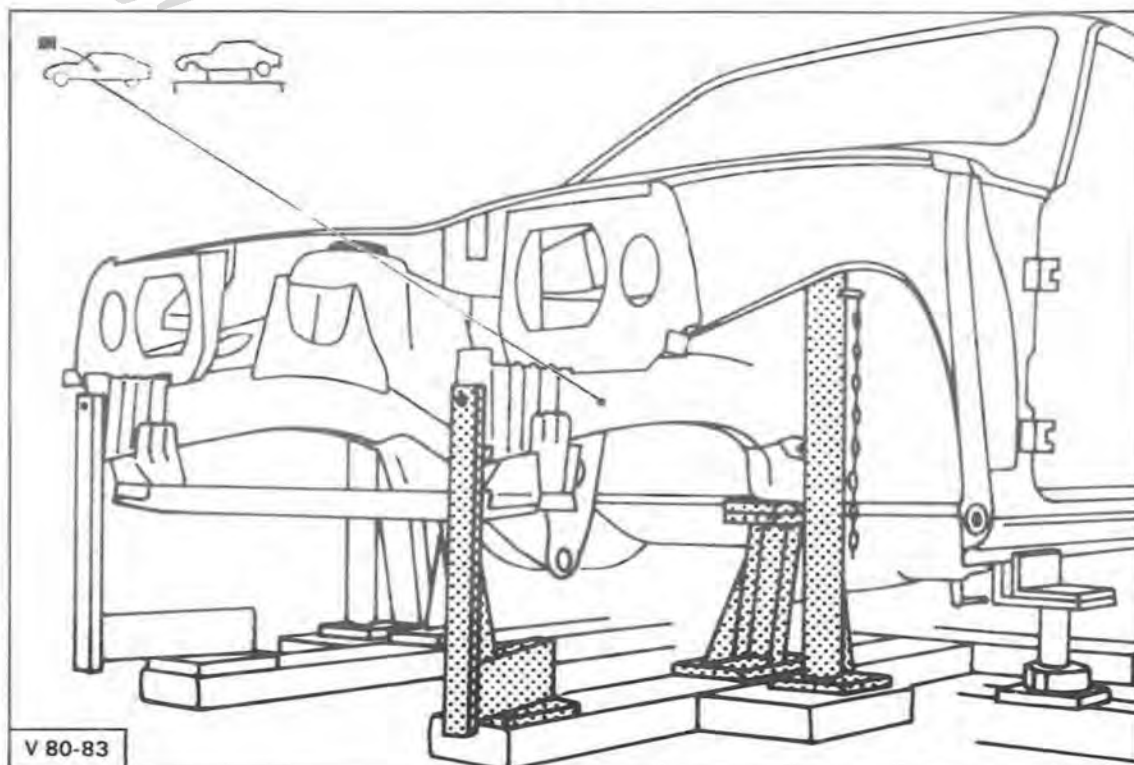
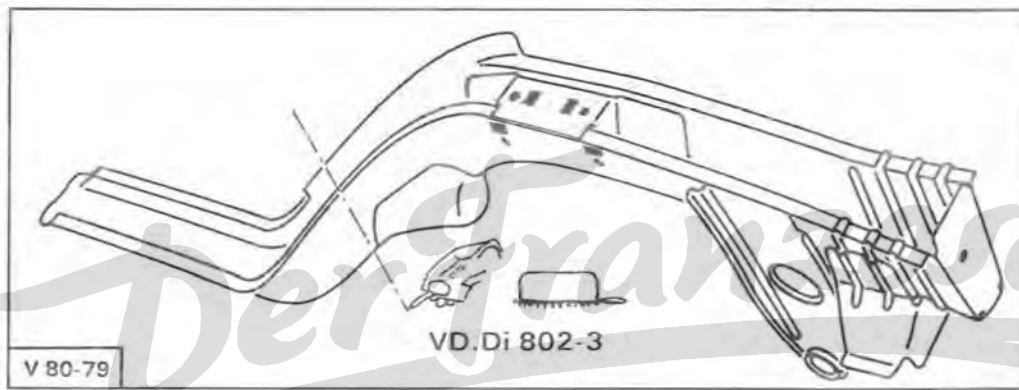
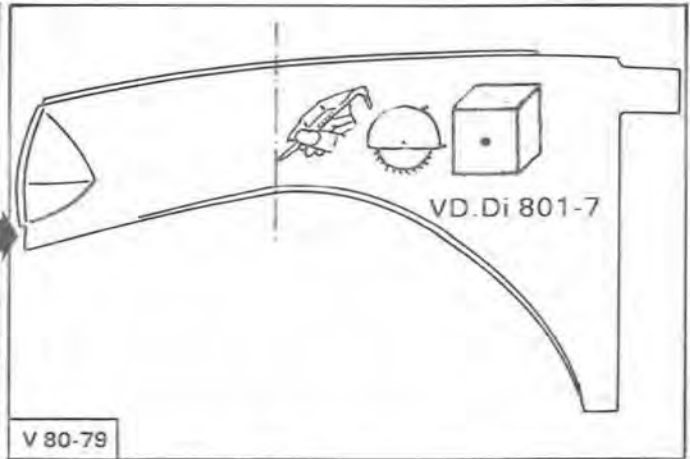
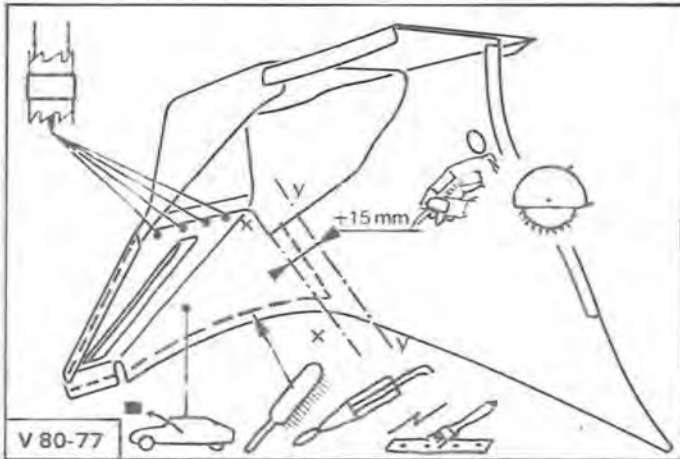

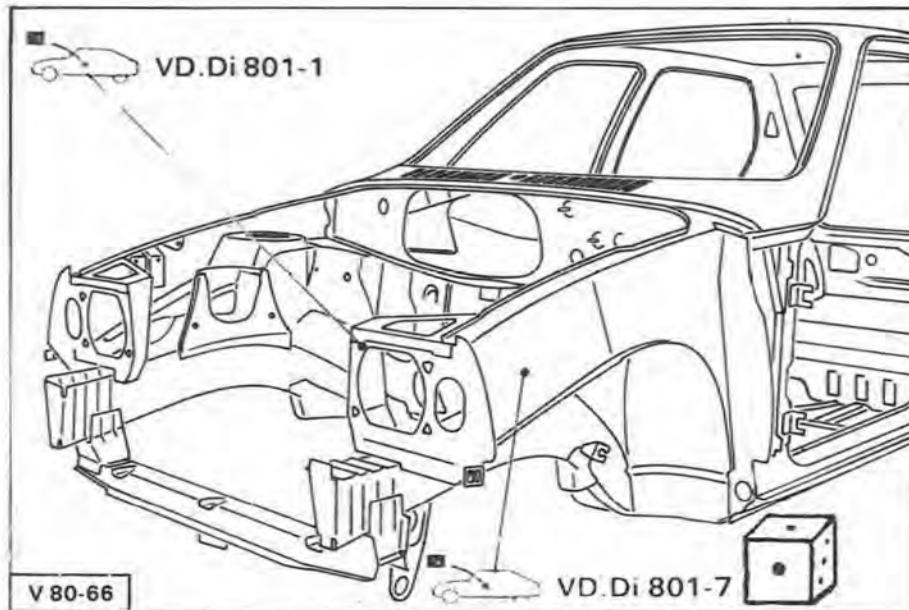
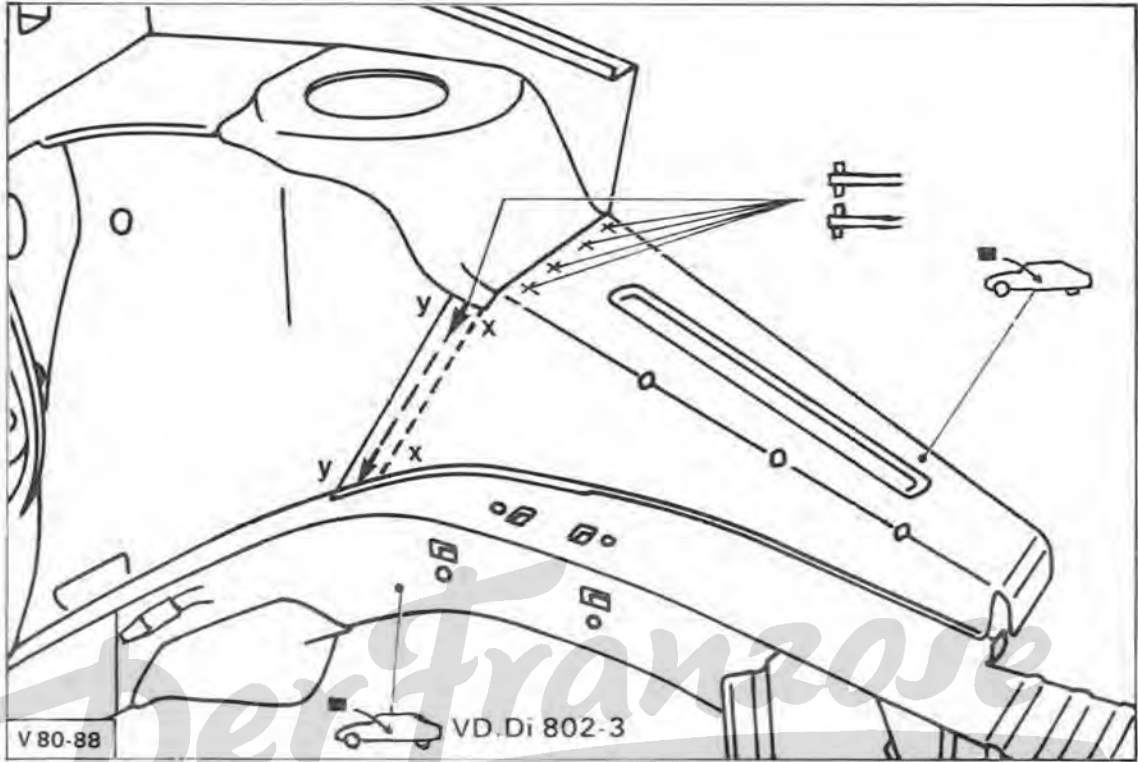

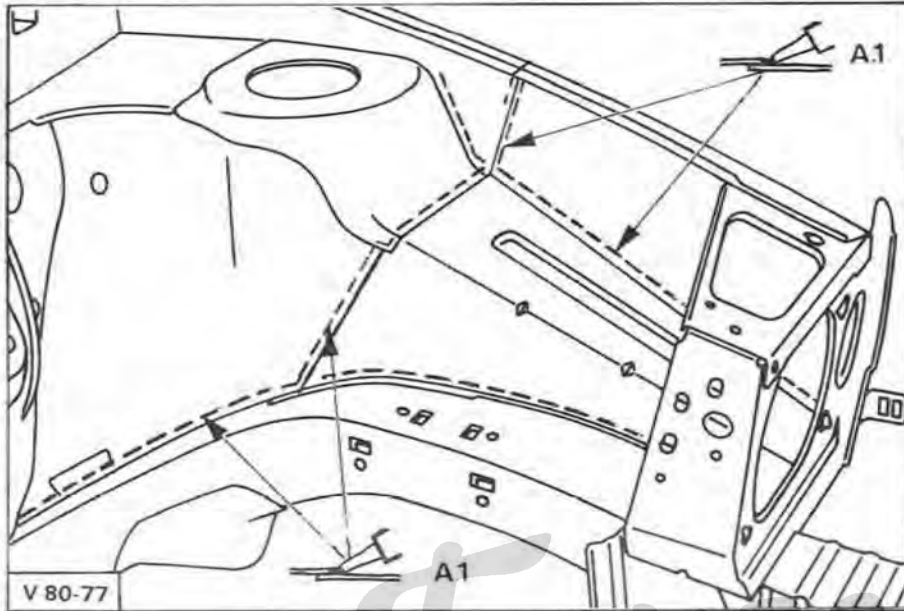

Der Franzose

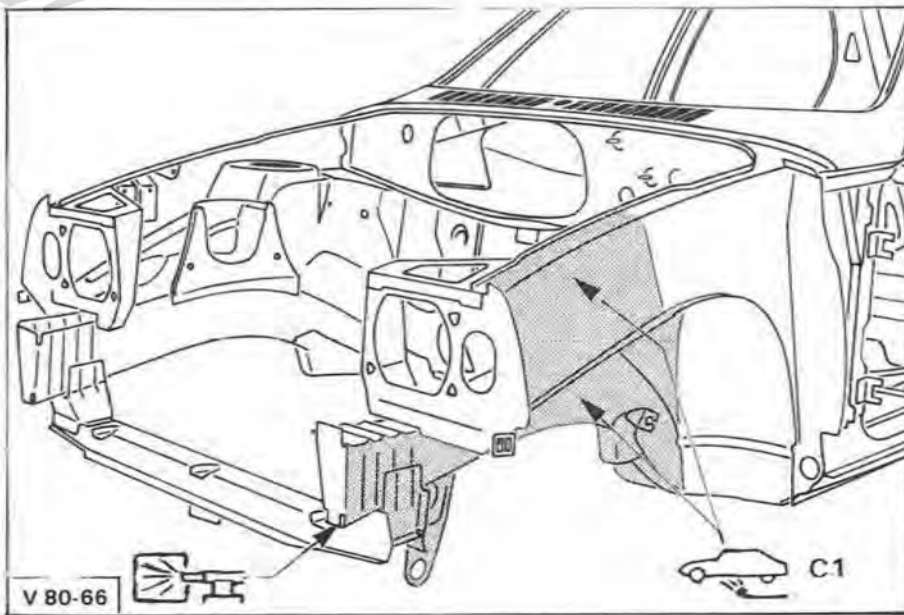

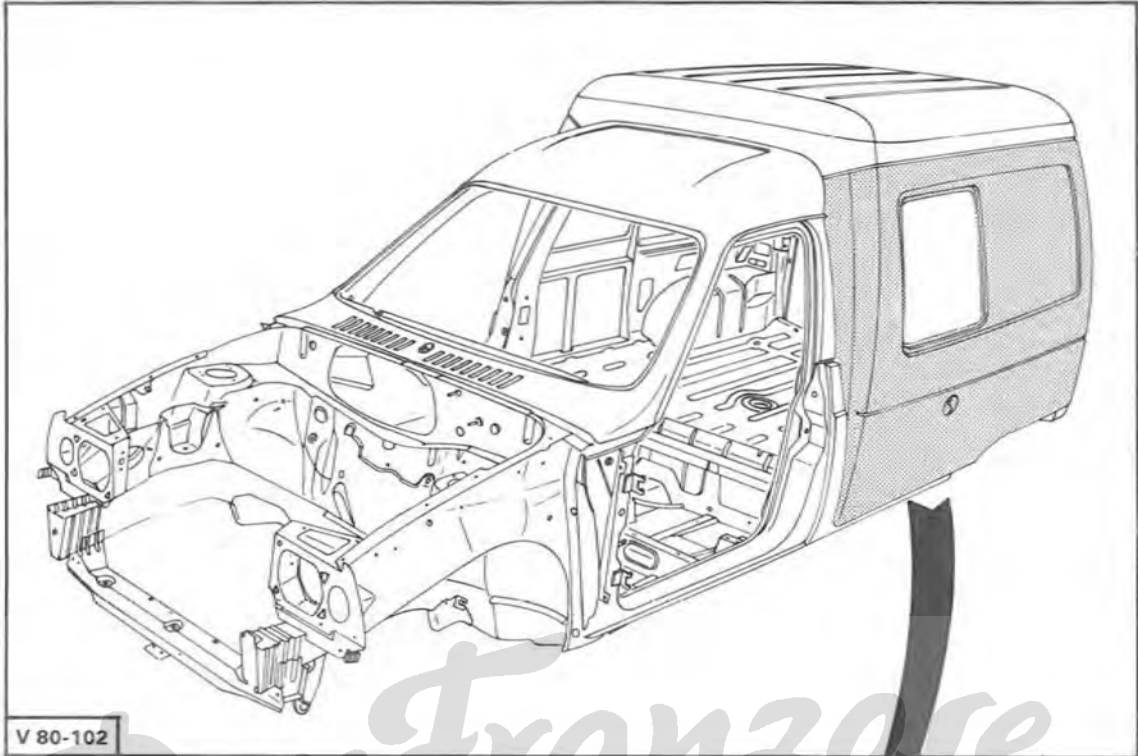

Der Franzose

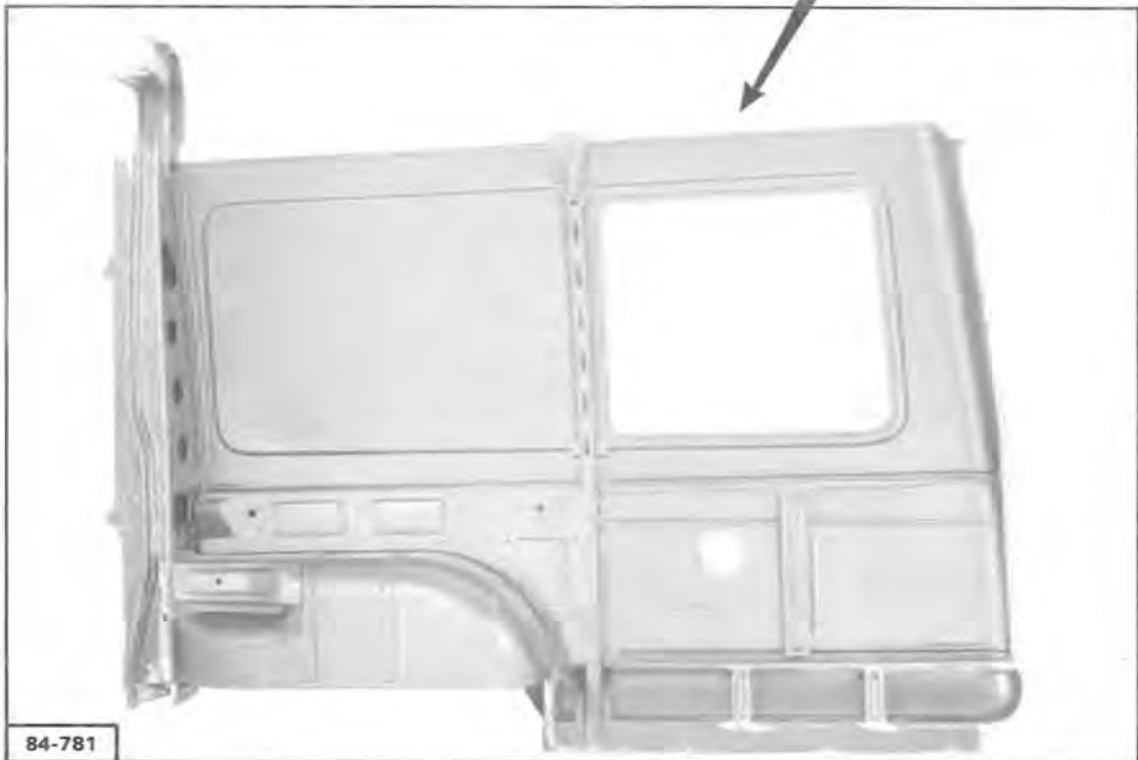
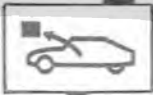

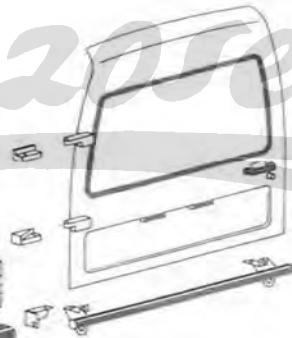
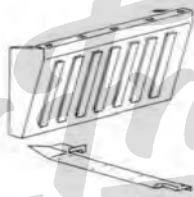
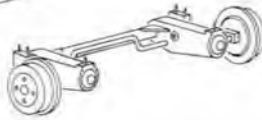
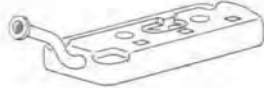
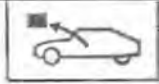

V 80-121 V 80-73

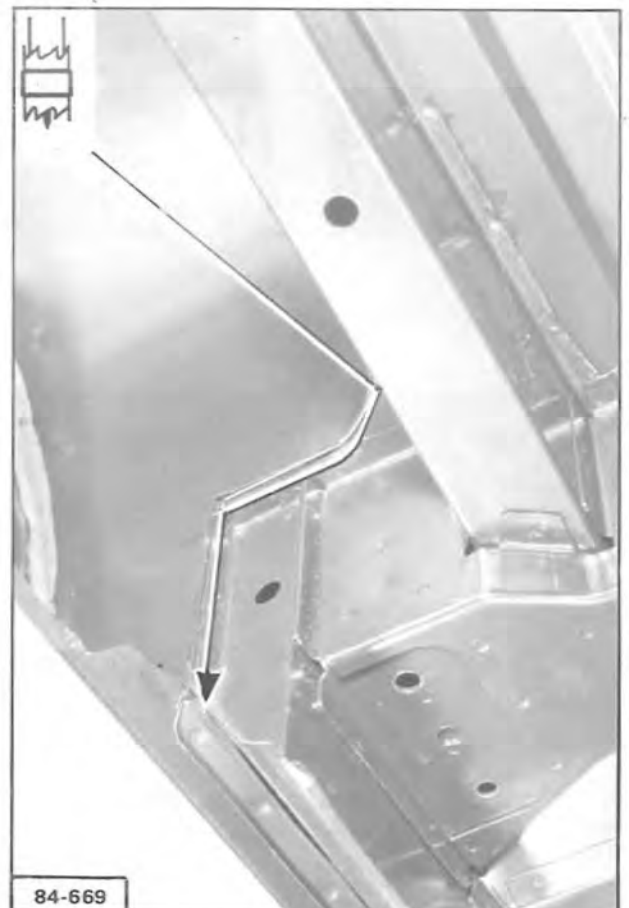
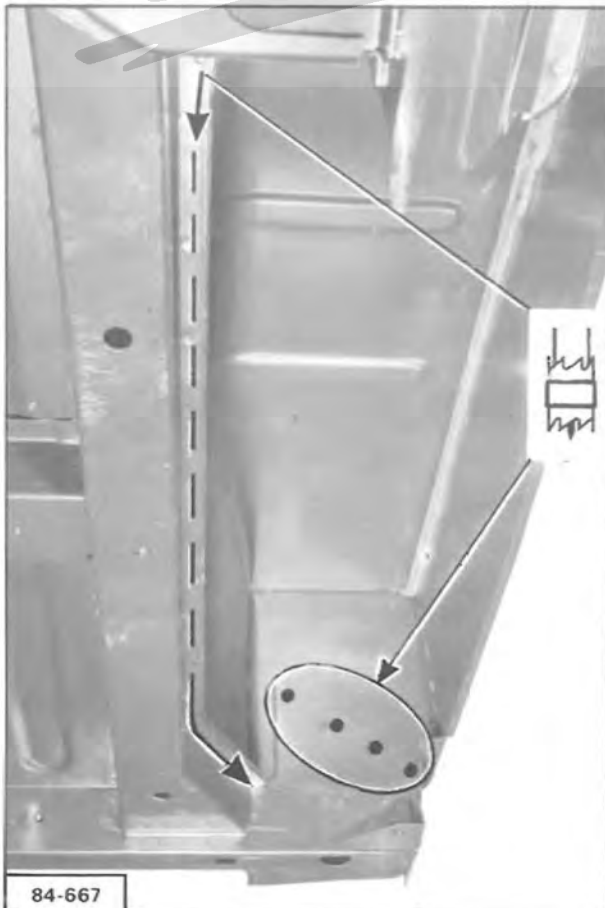
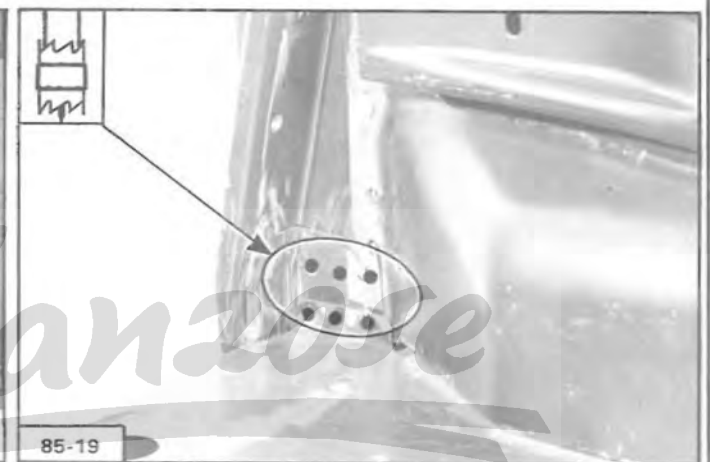
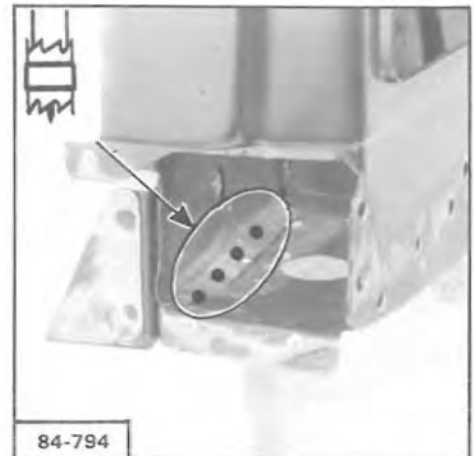
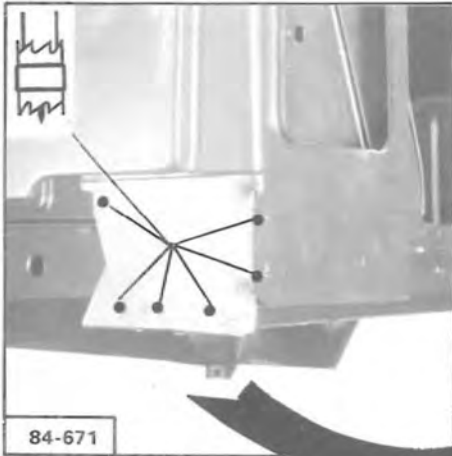

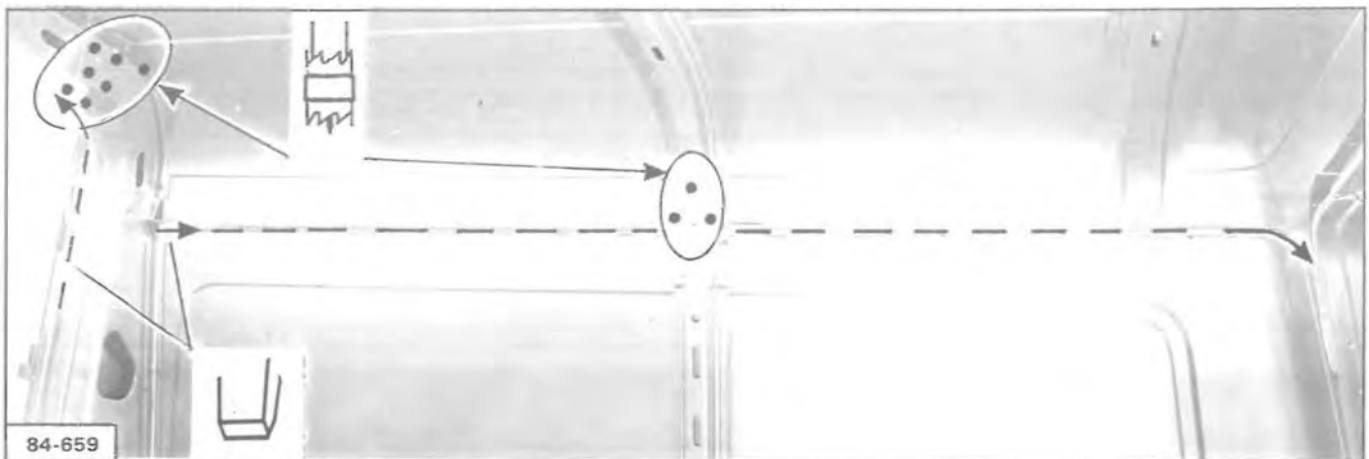
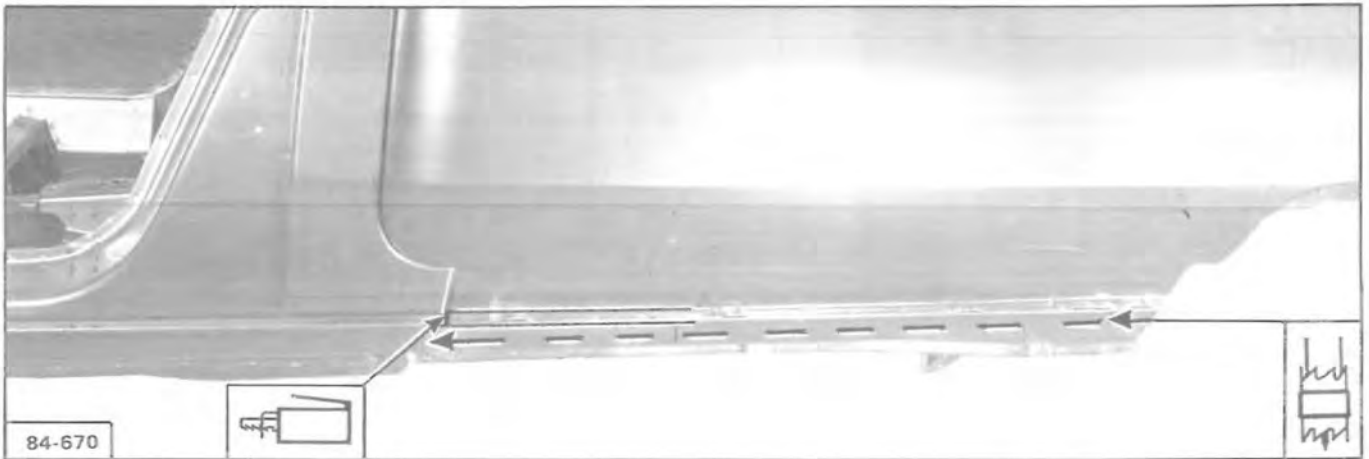



84-780

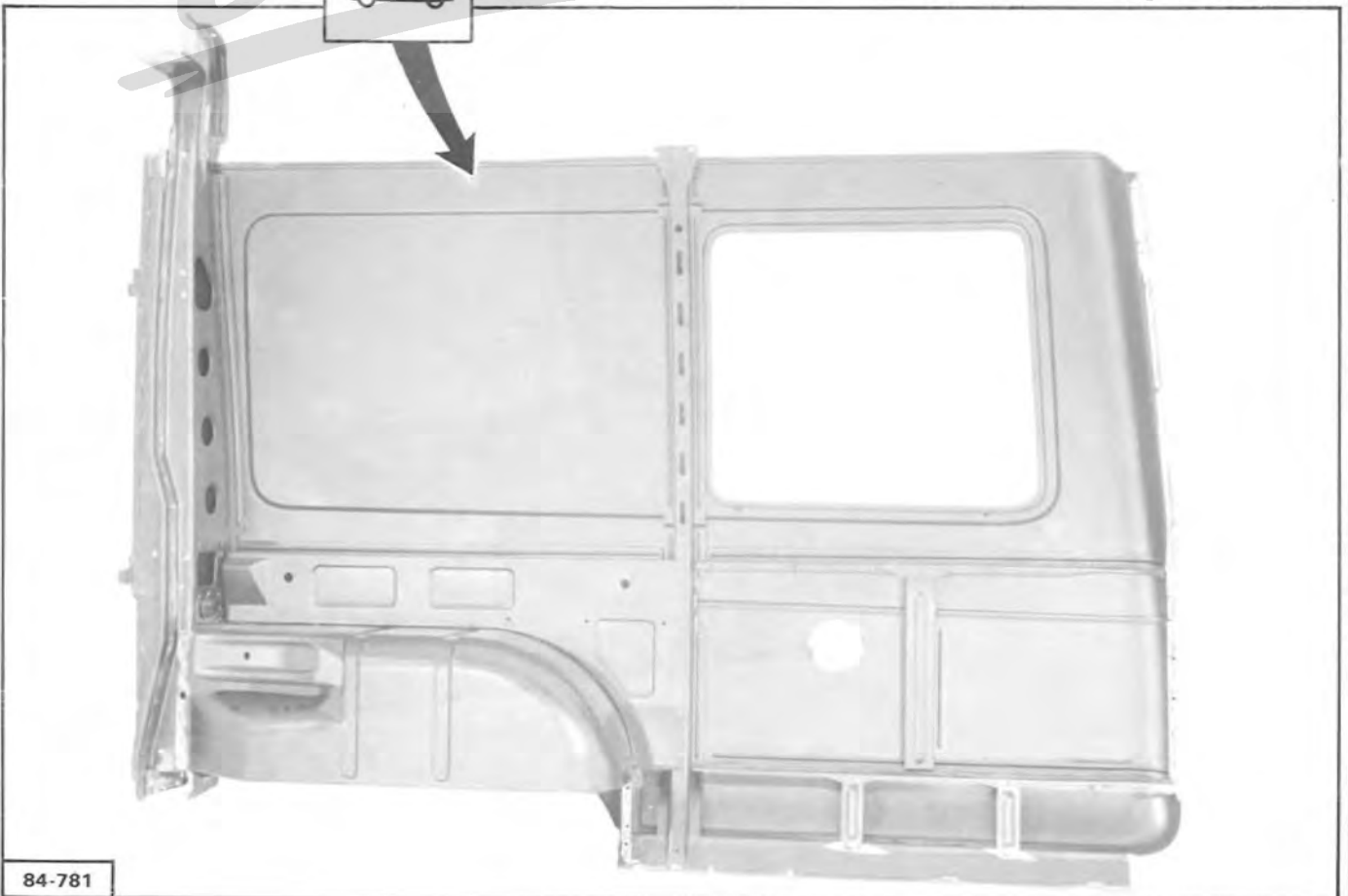

84-781

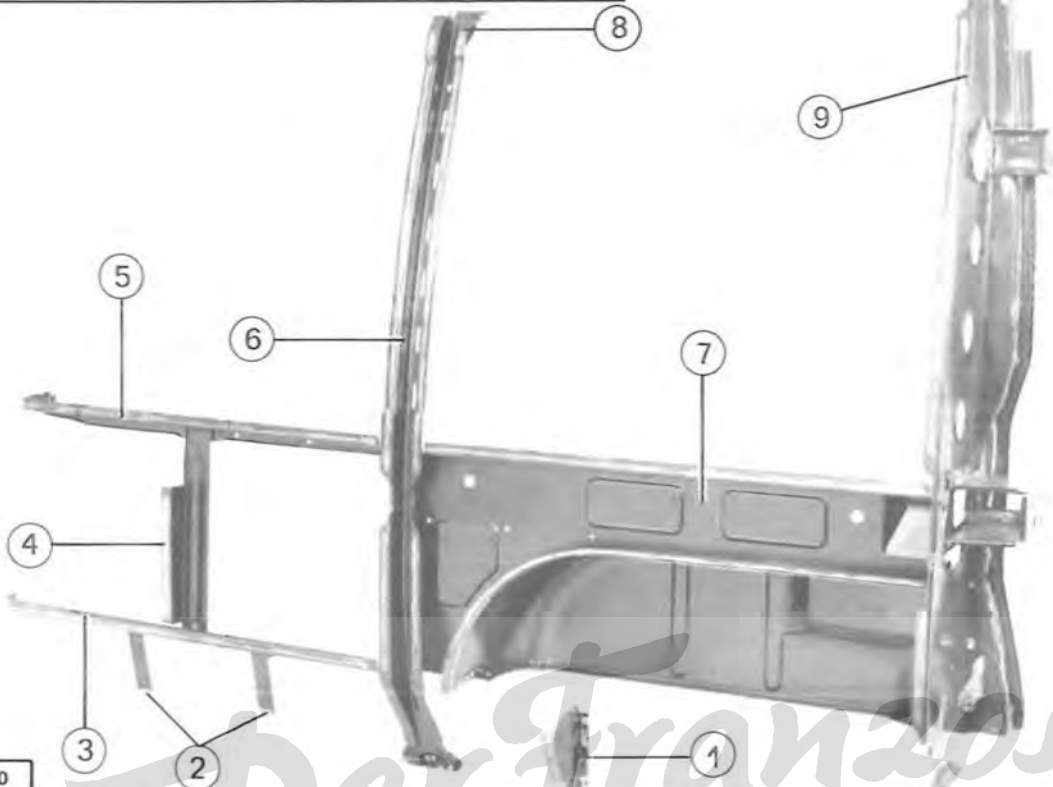
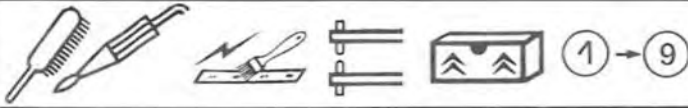

84-840

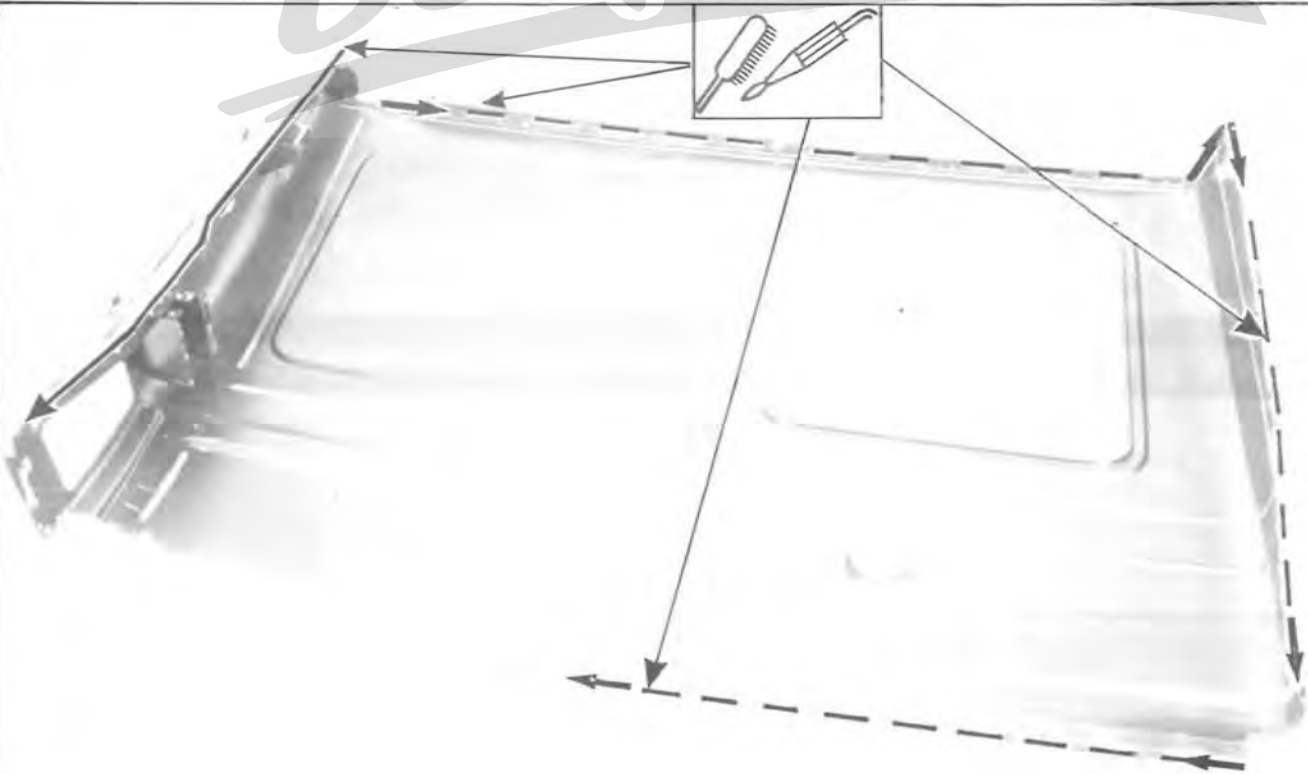

84-776

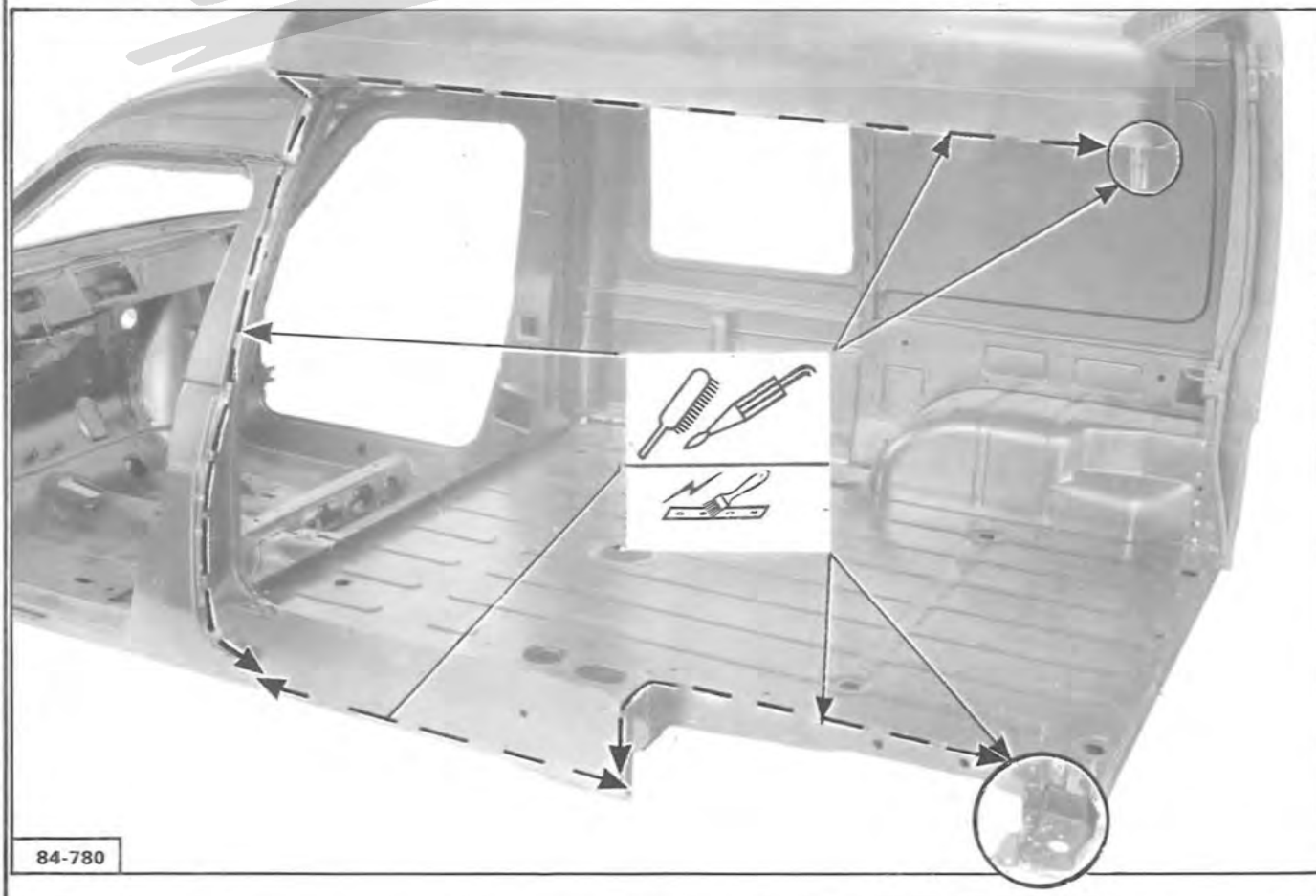
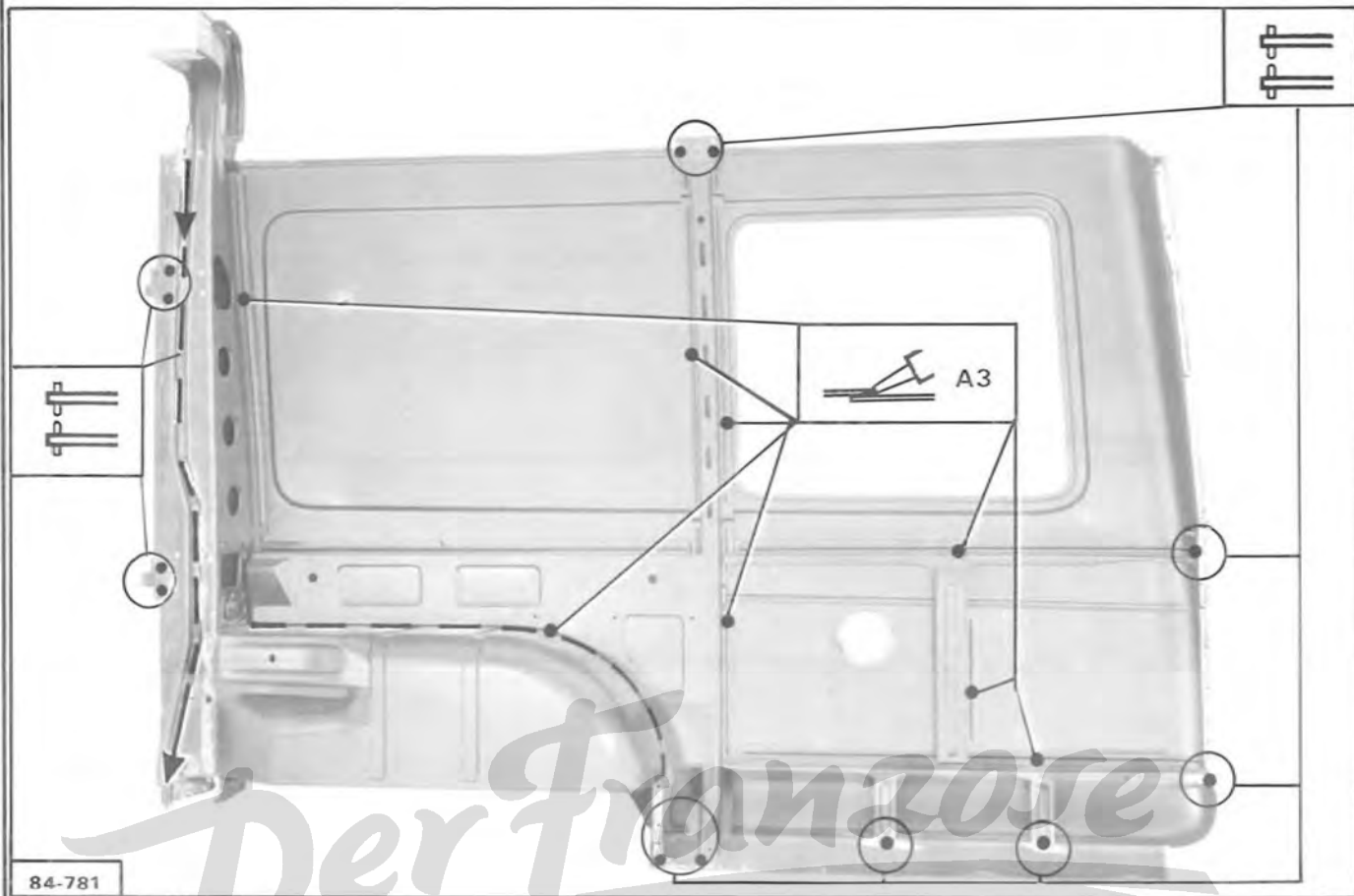

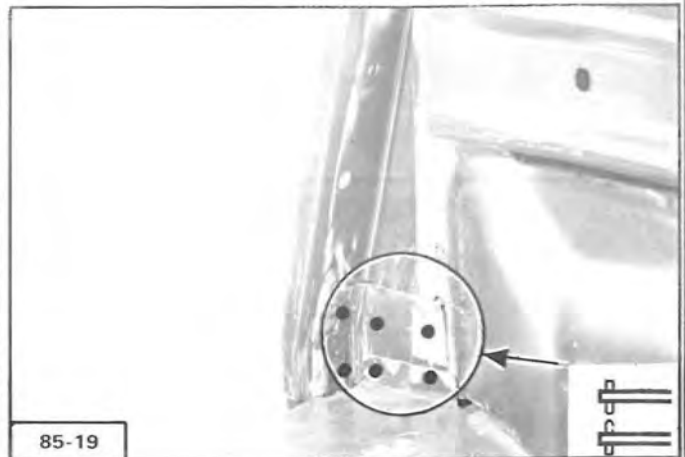
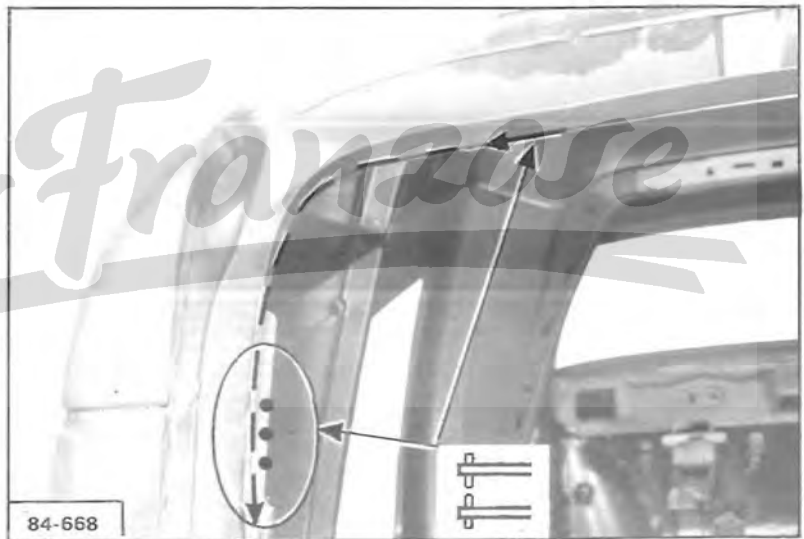
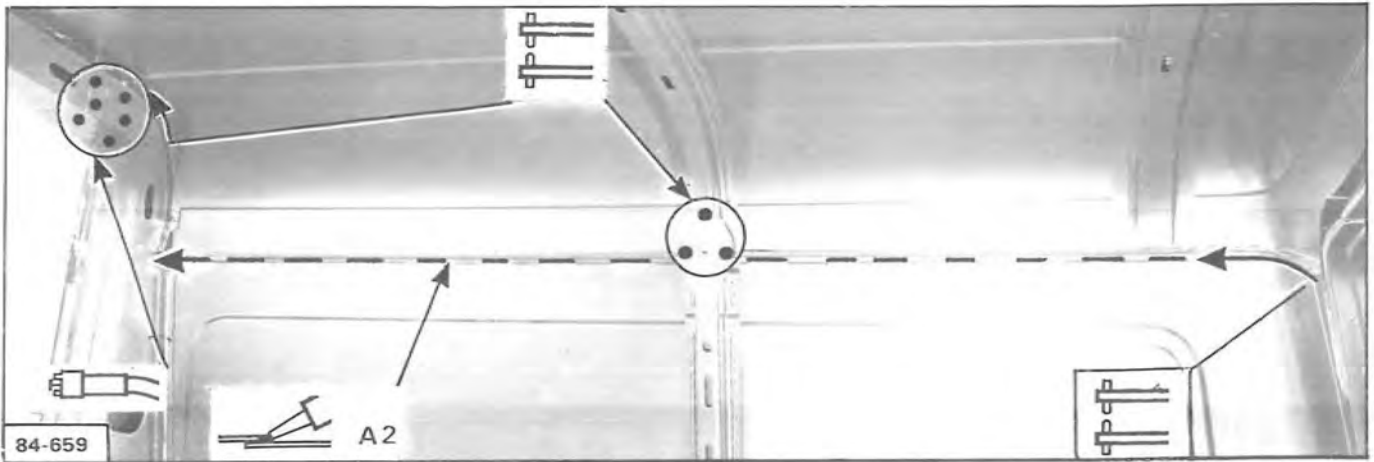

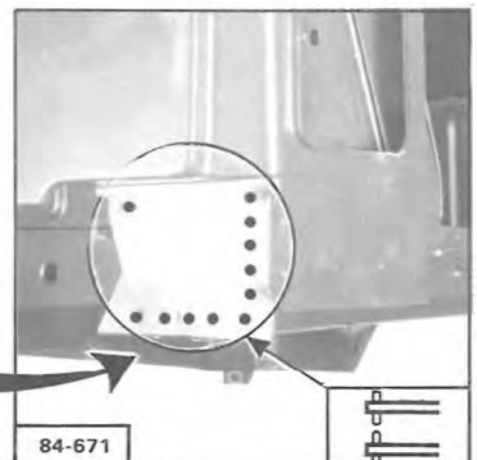
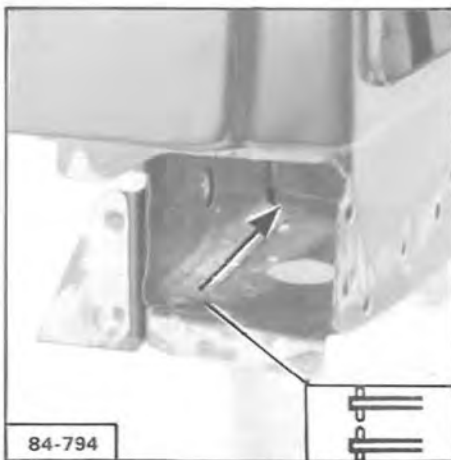
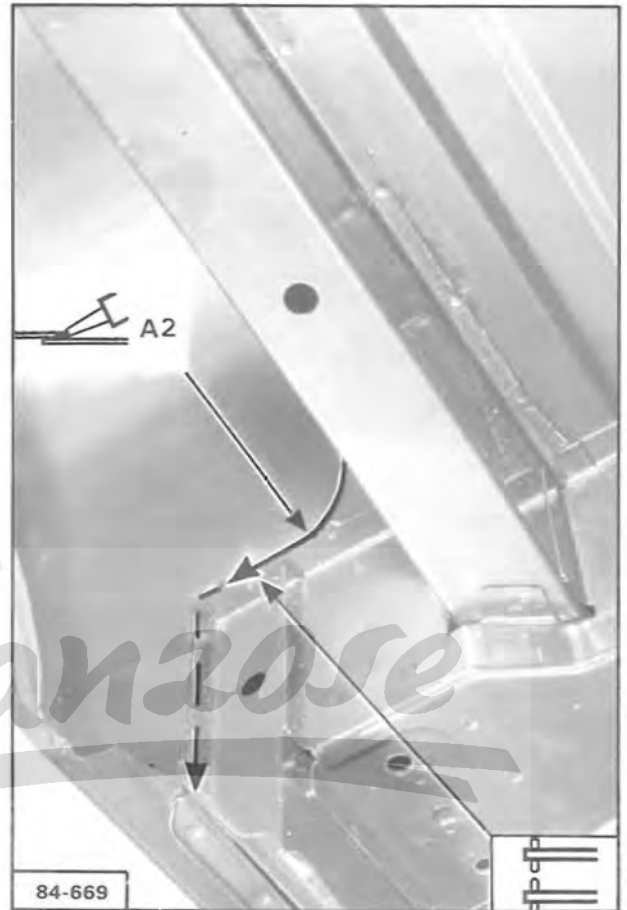

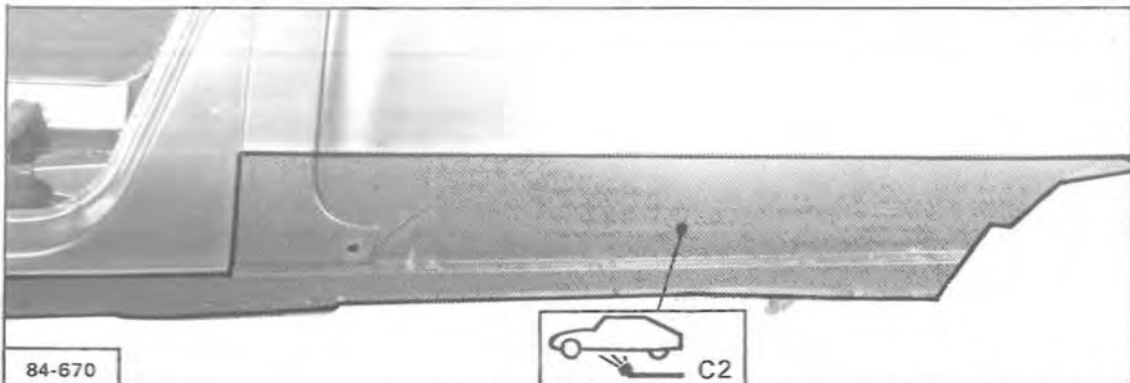
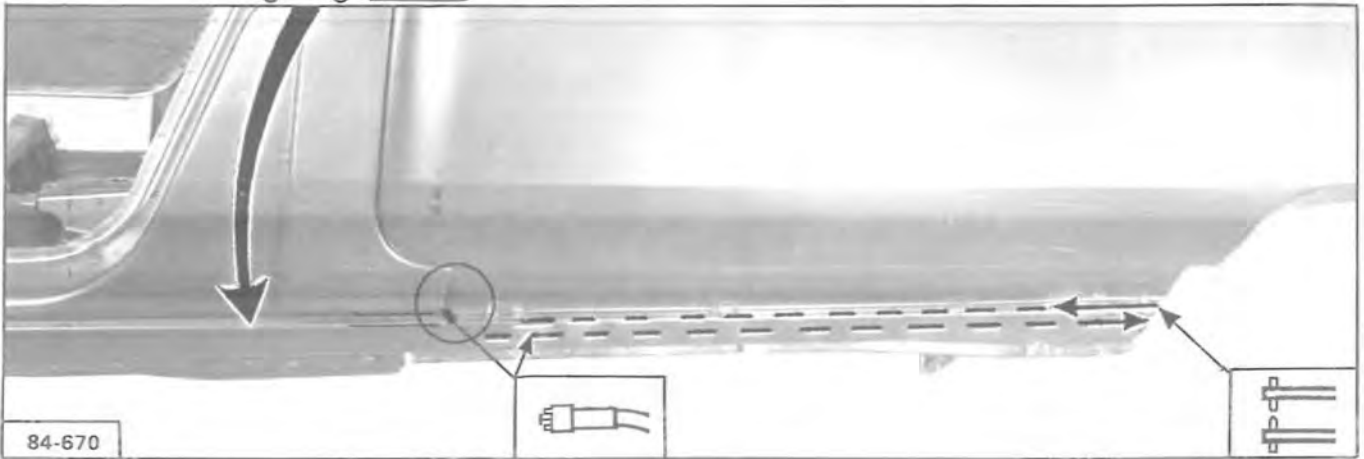
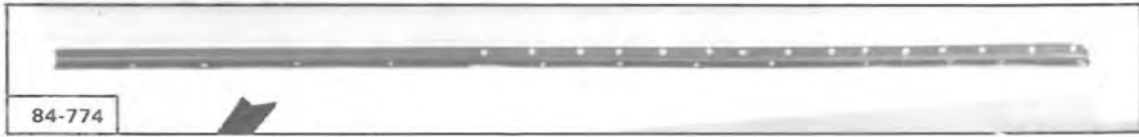

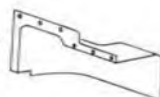
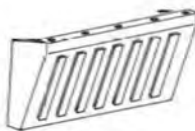
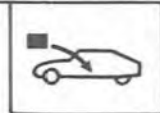

V 80-121 V 80-73

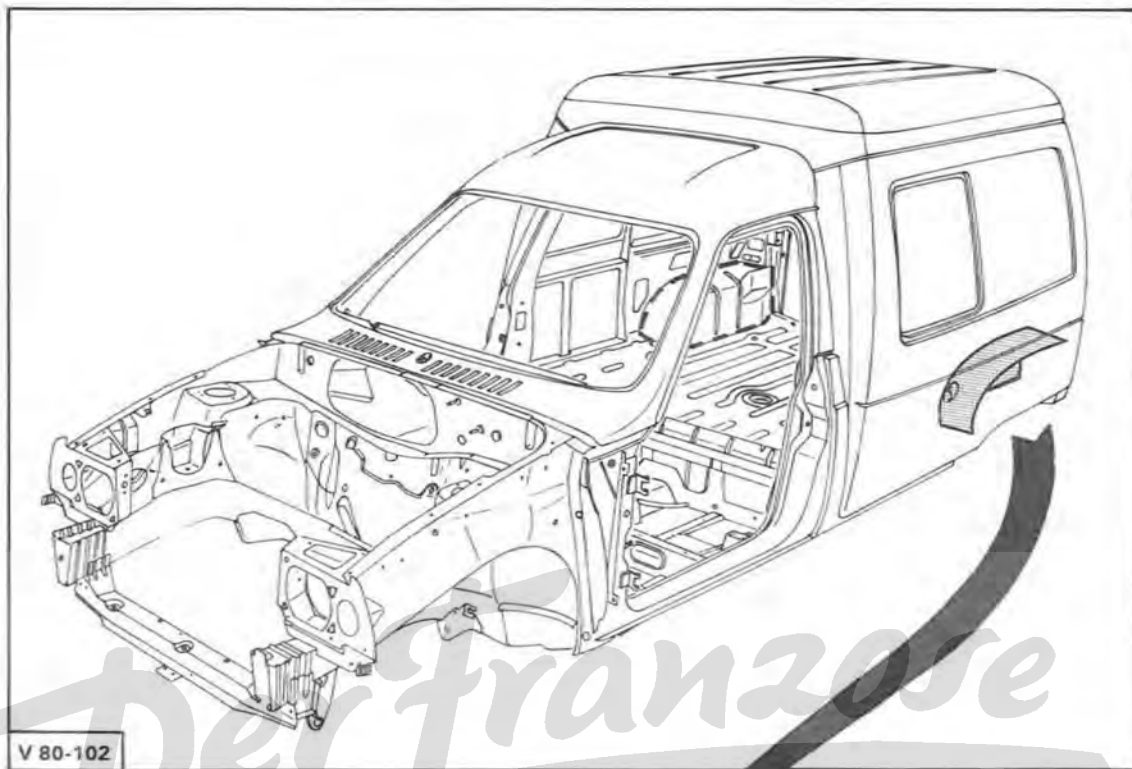

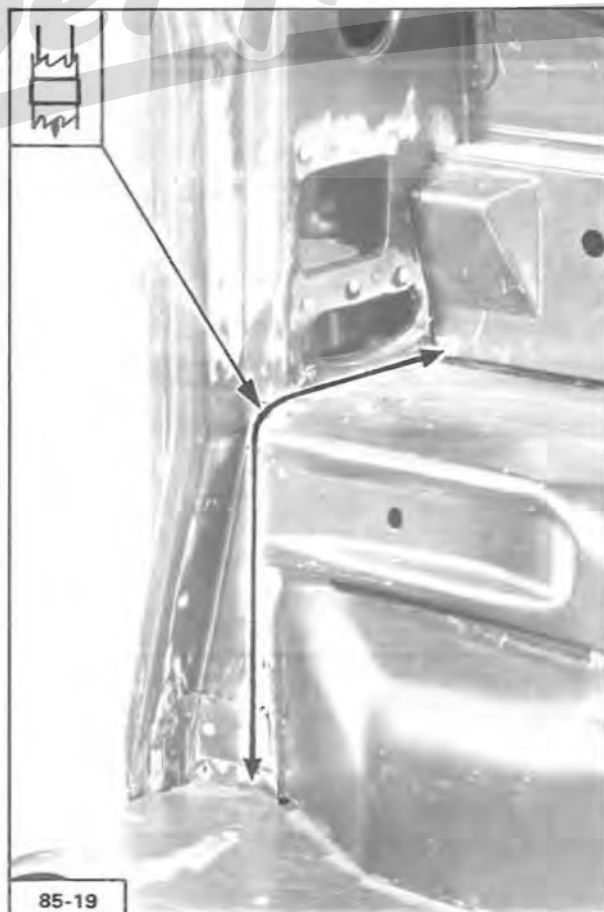
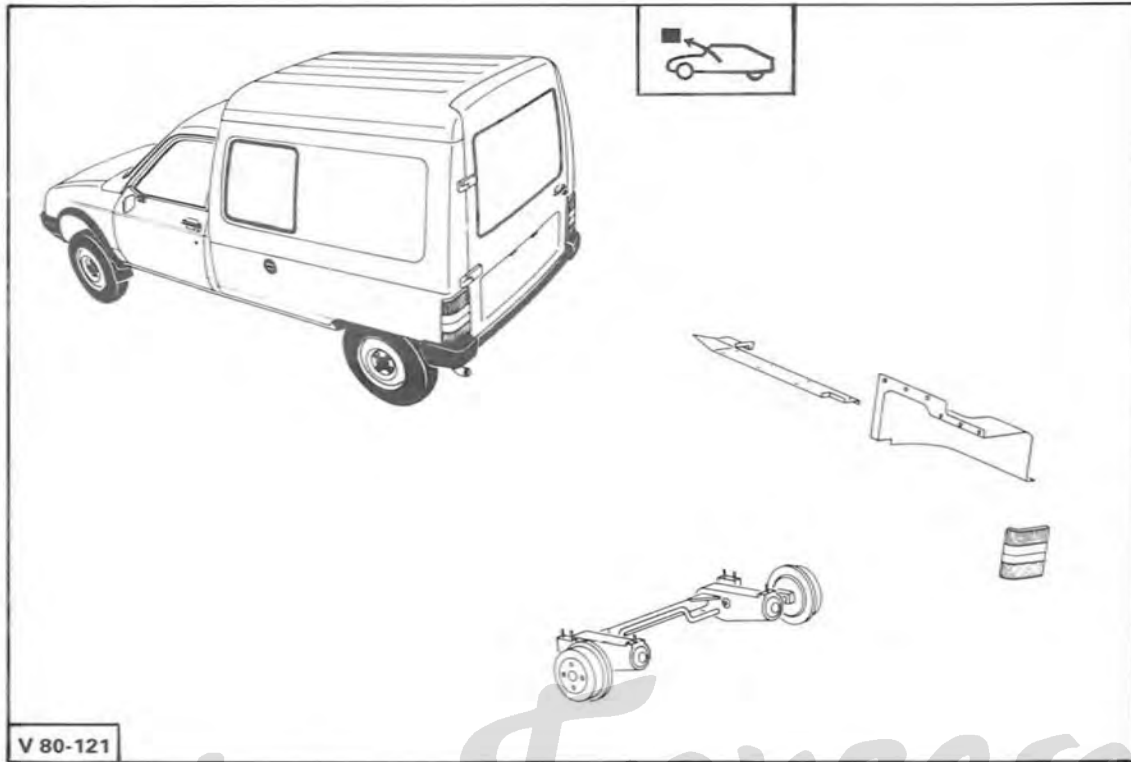

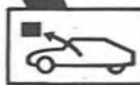

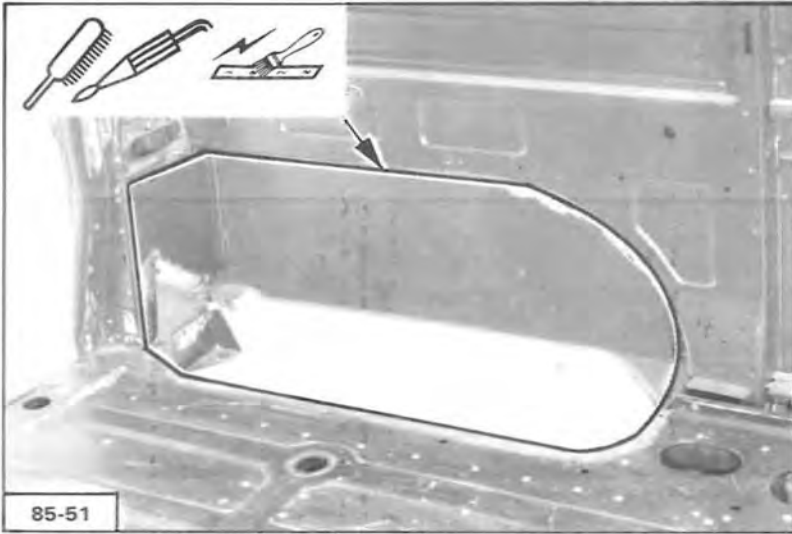

Der Franzose

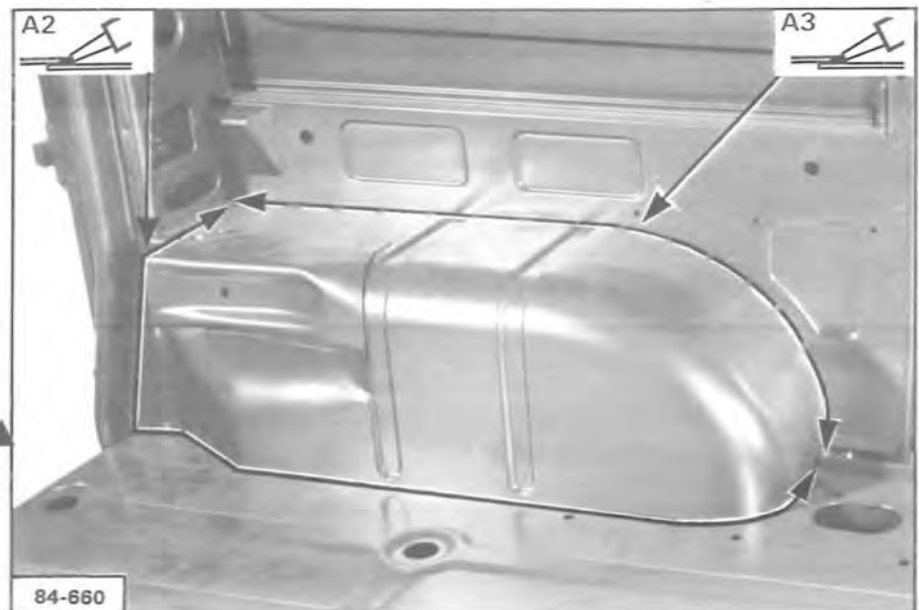

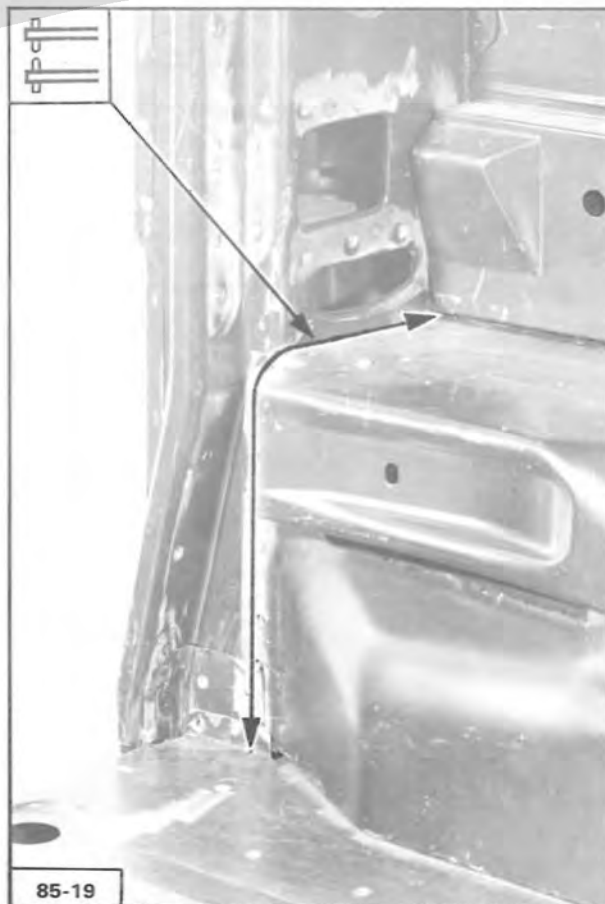

Der Franzose

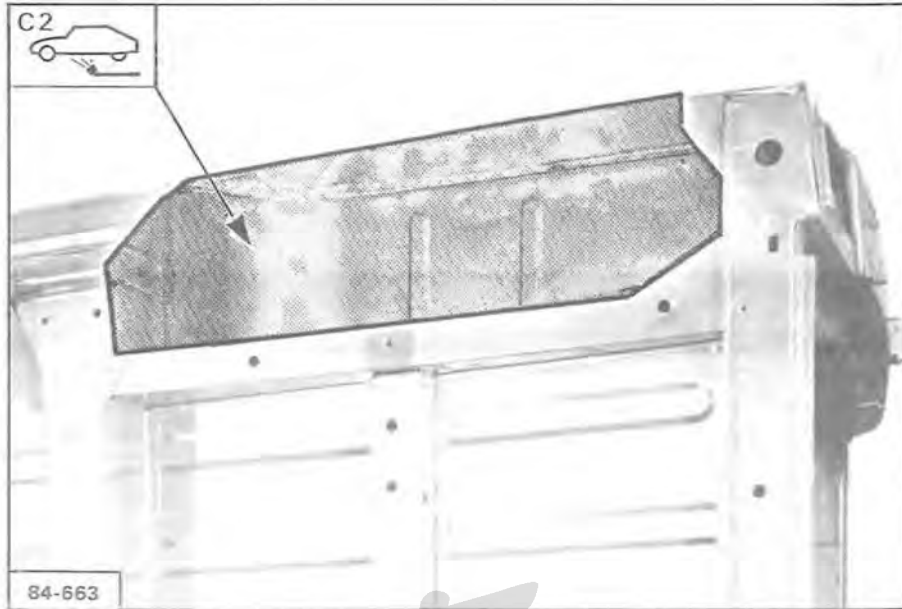

Der Franzose

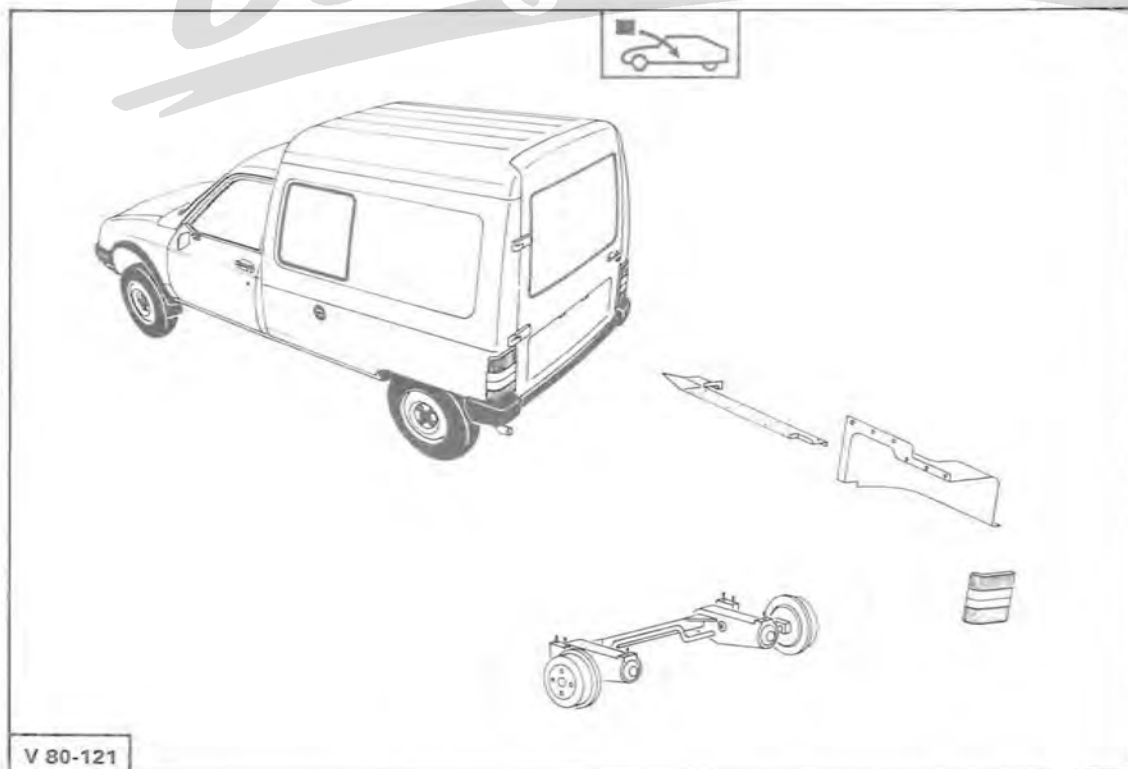

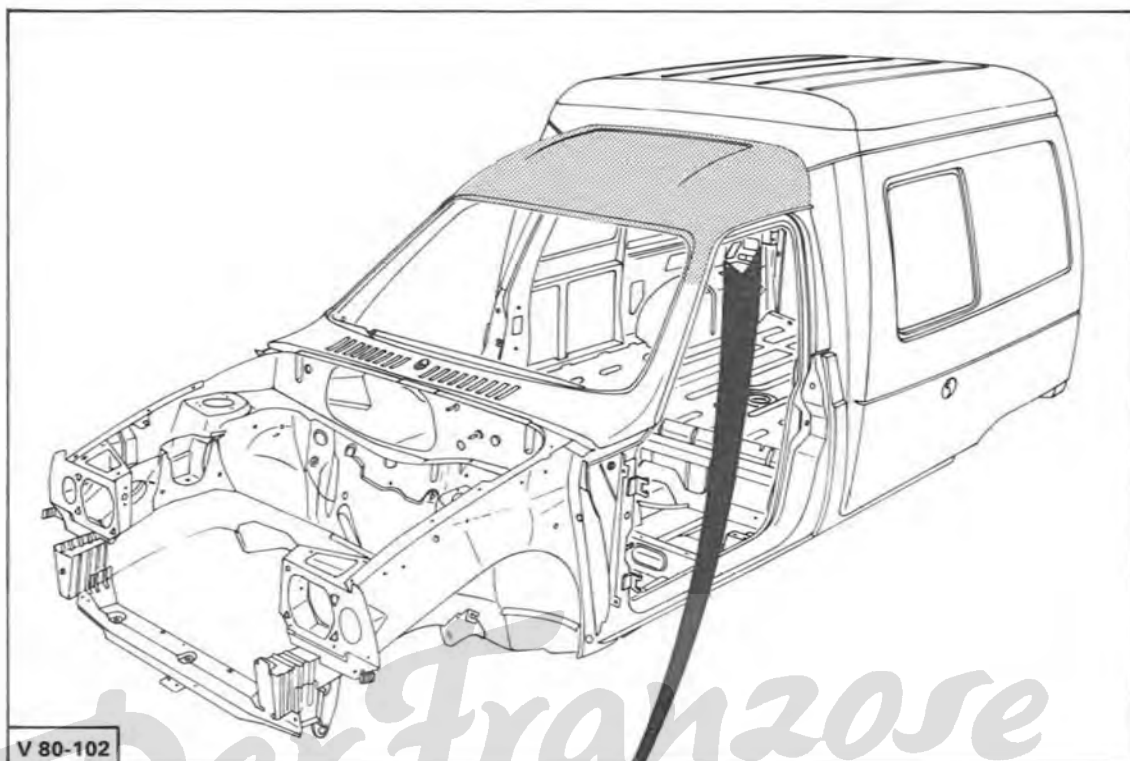

V 80-102



84-111

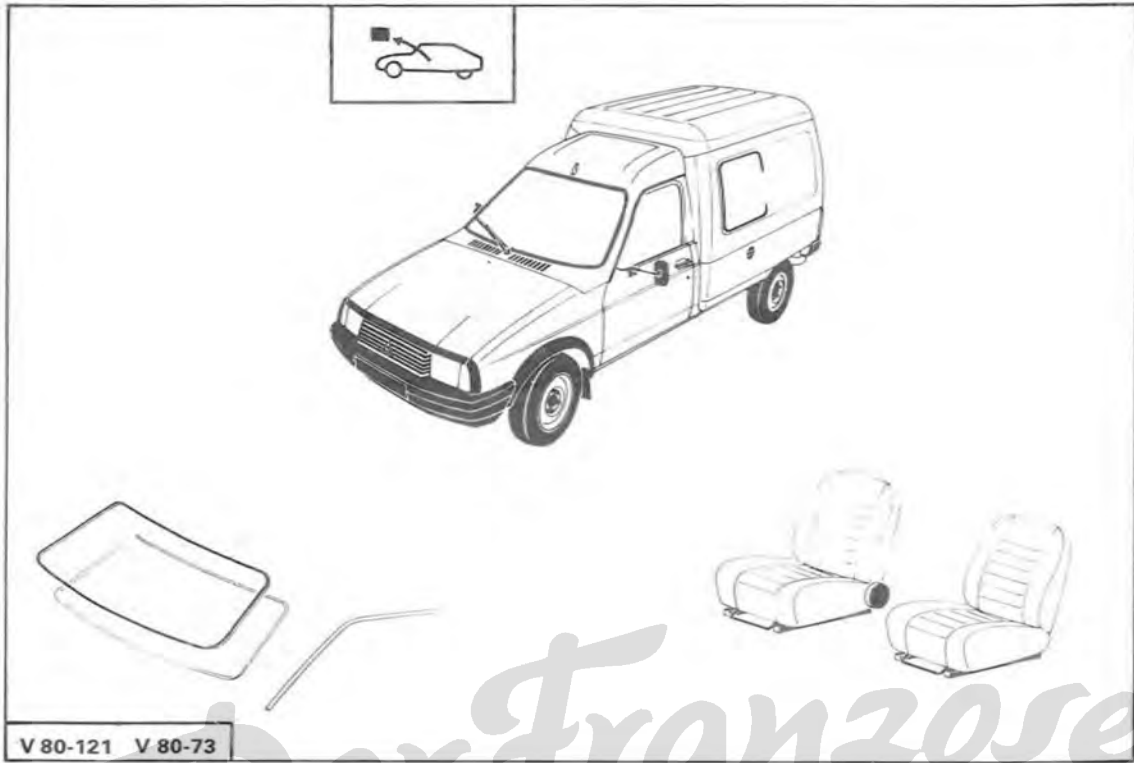

Der Franzose

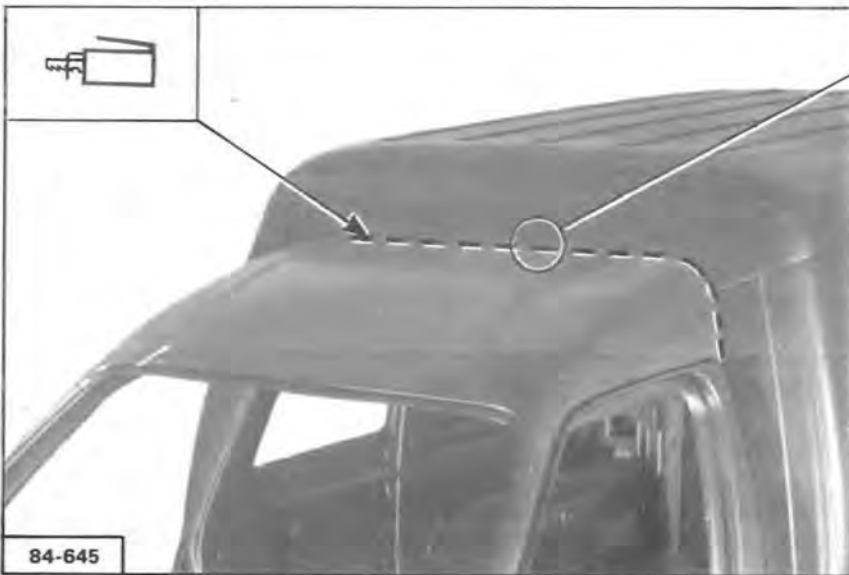
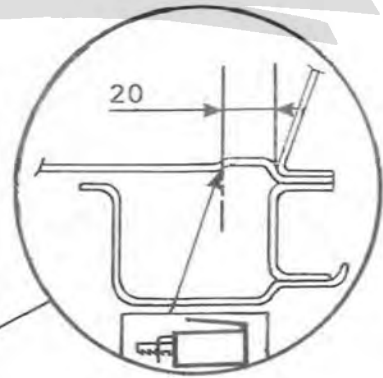

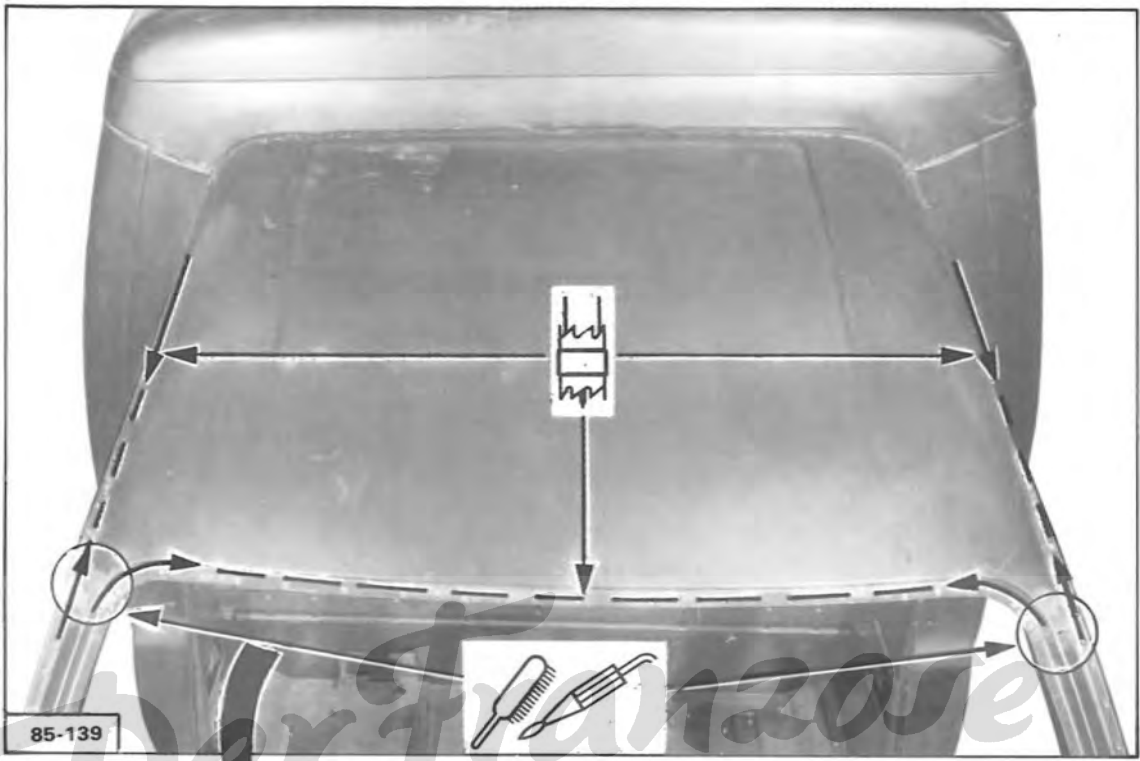



Der Franzose

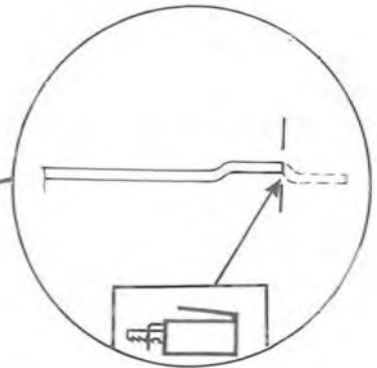
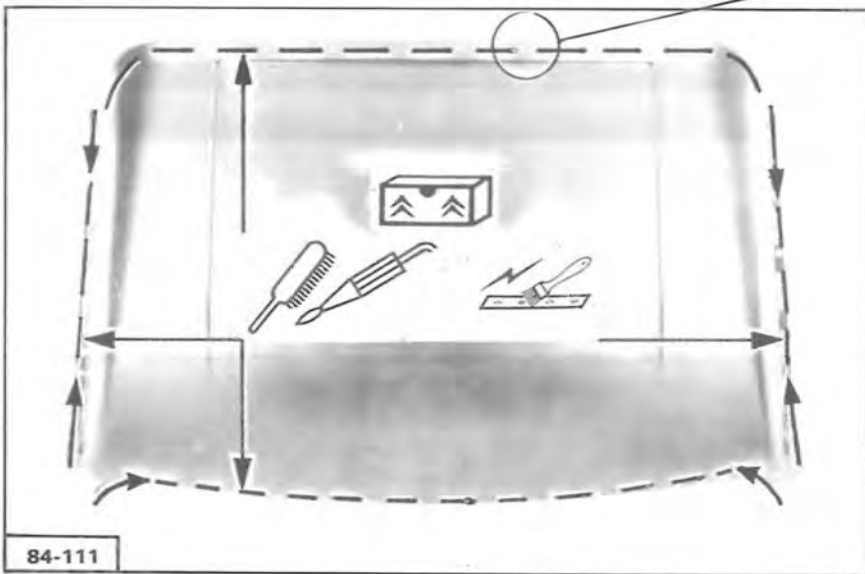



Der Franzose

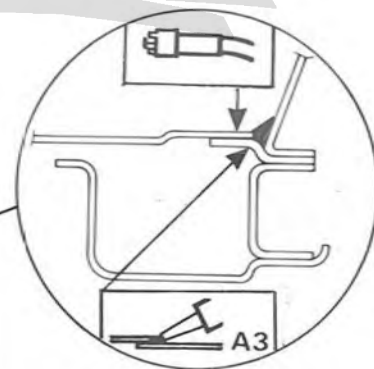
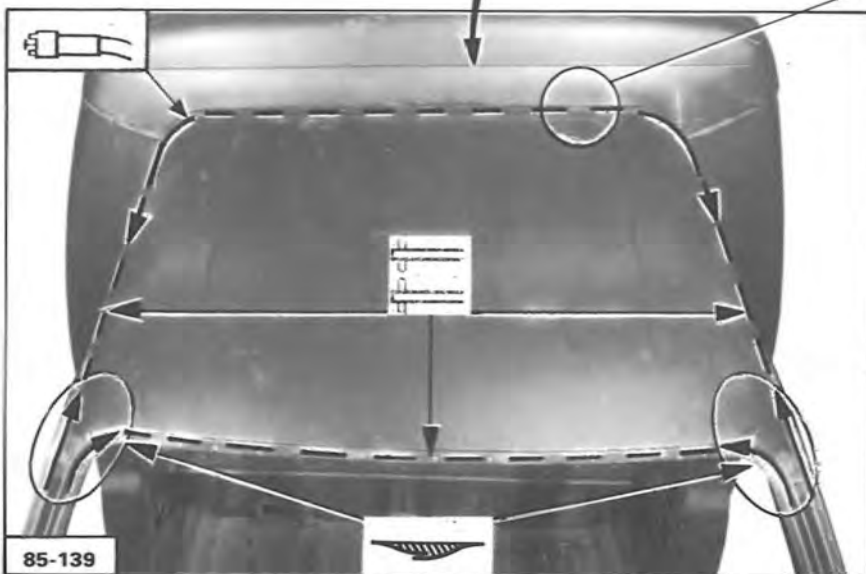
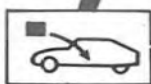

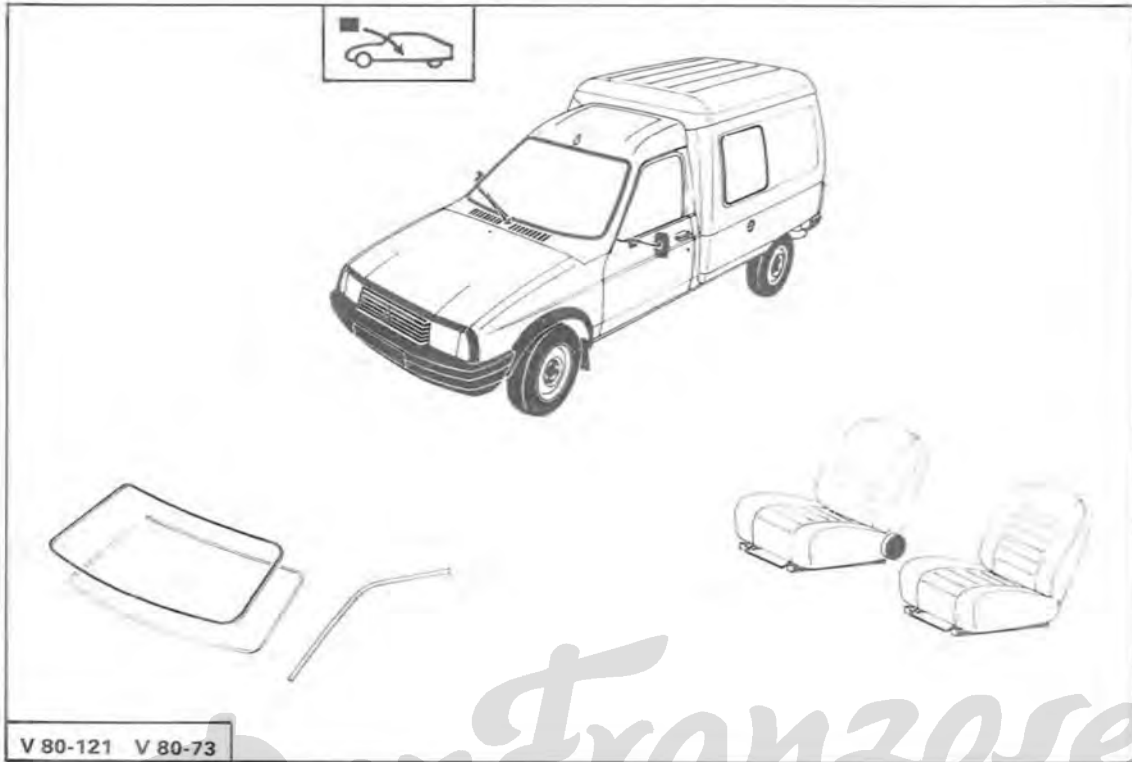

V 80-121 V 80-73

Der Franzose

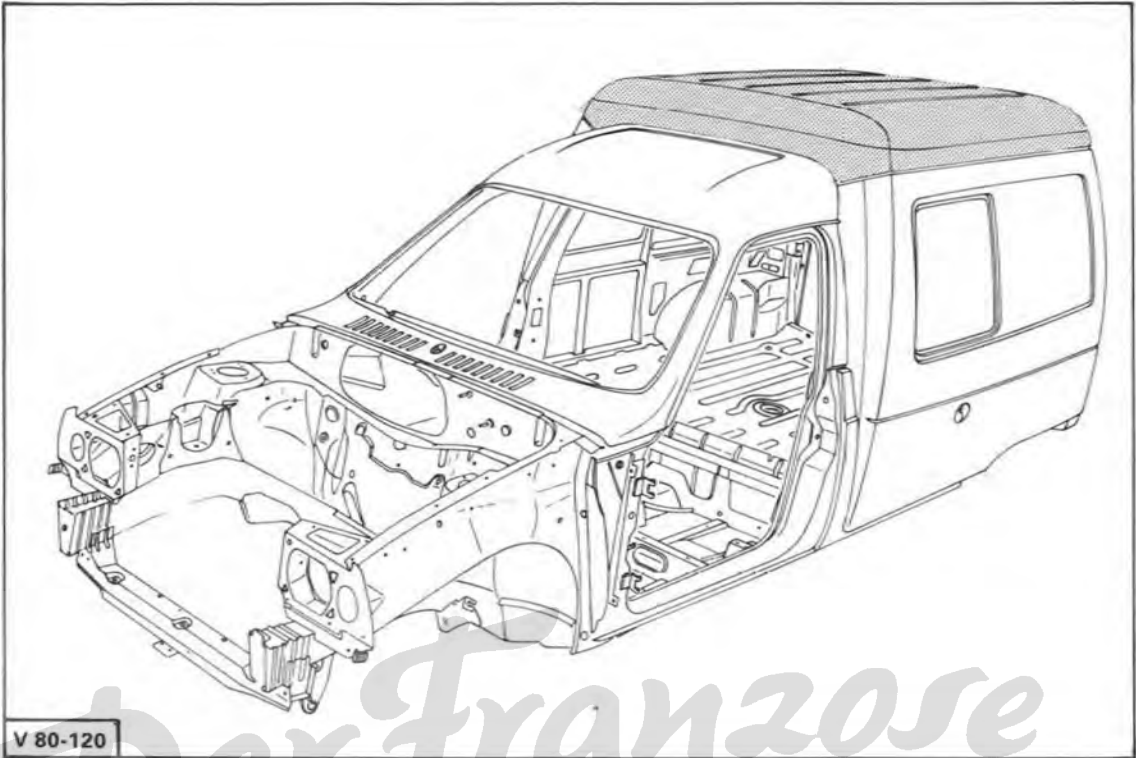

V 80-120



84-761

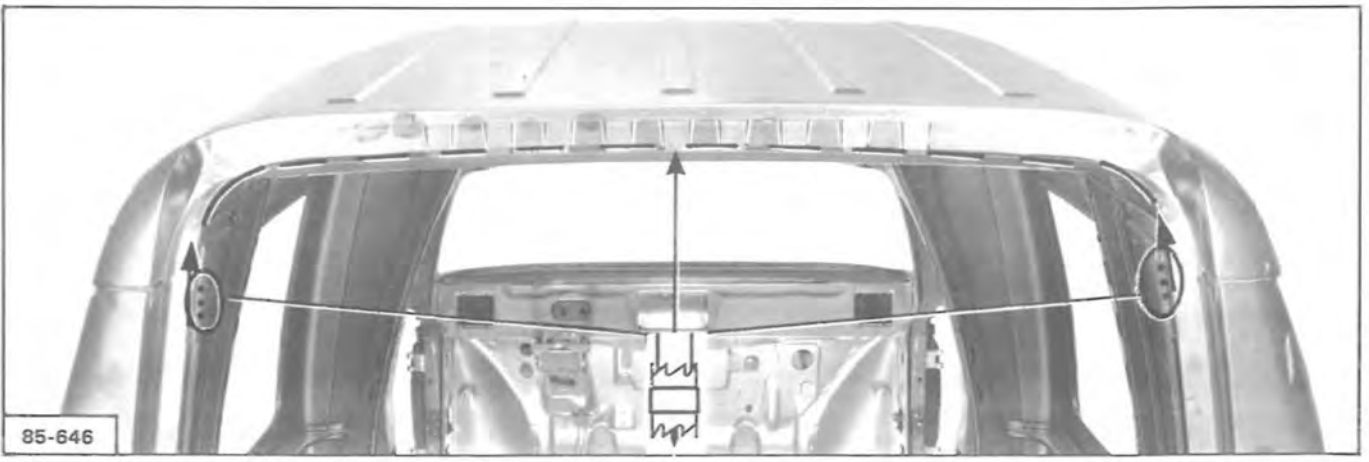
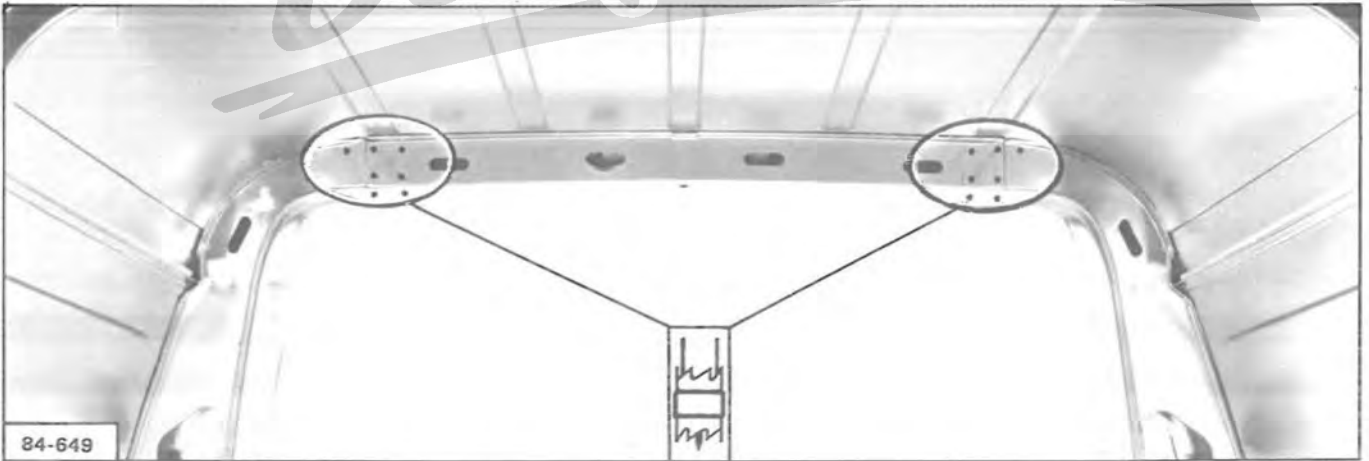
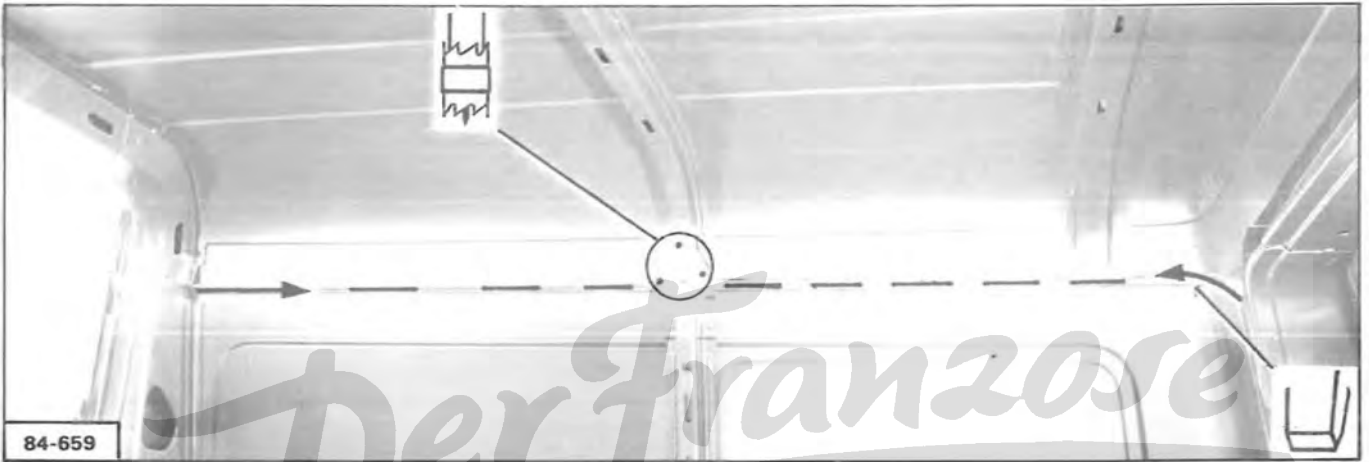
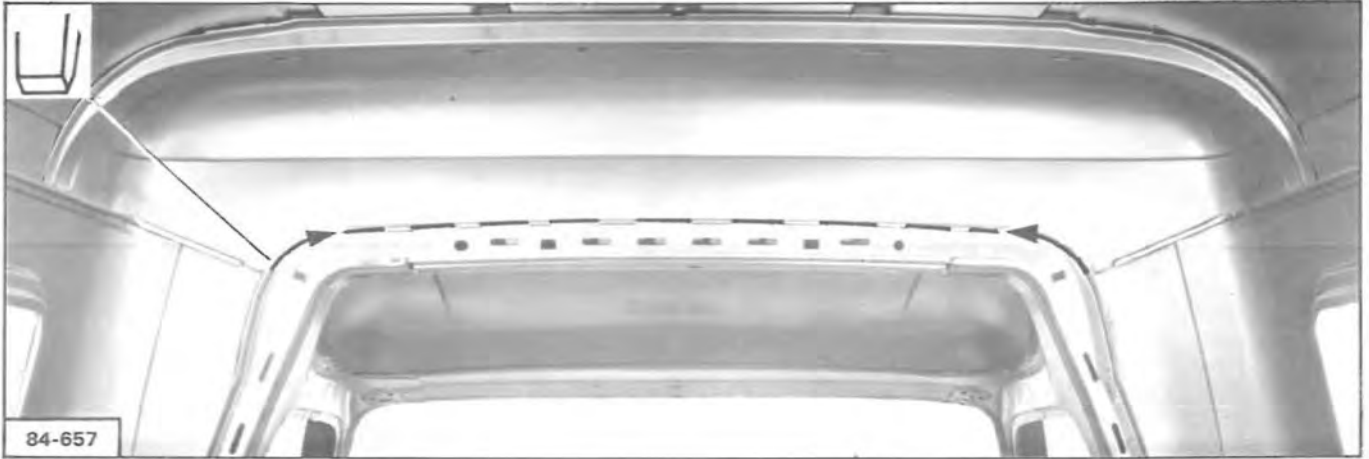

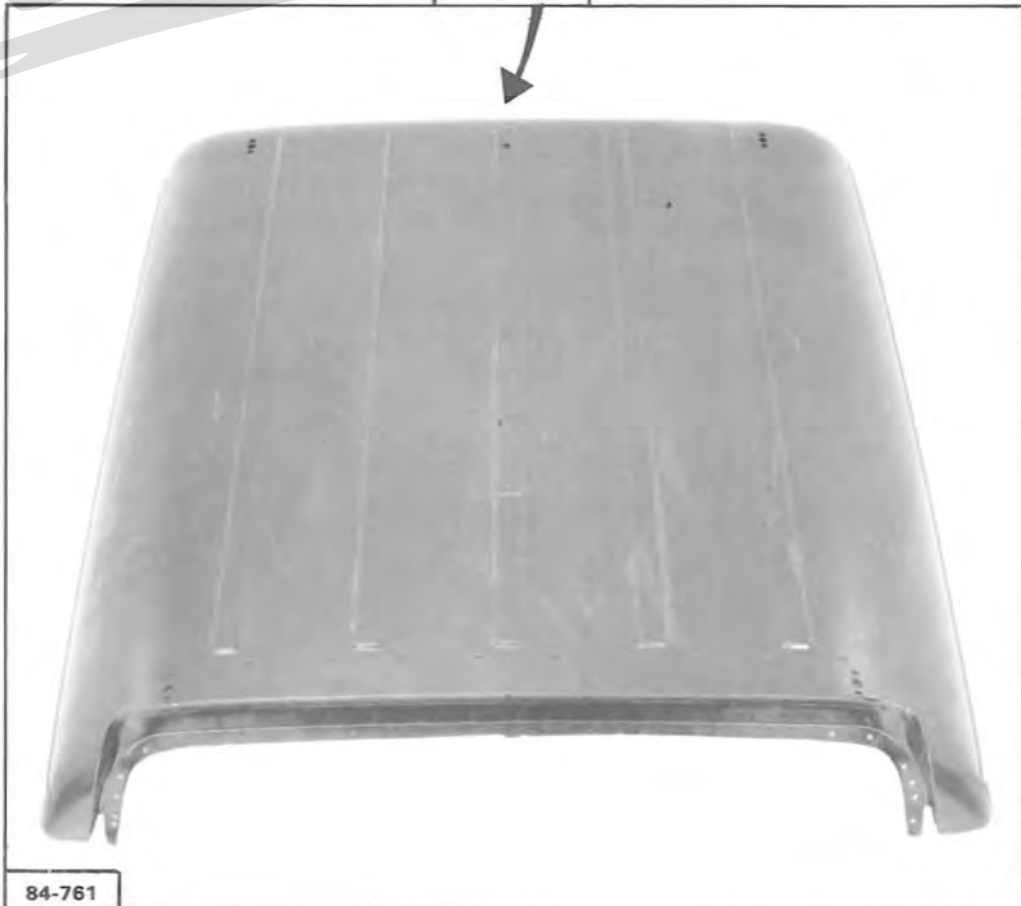
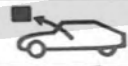

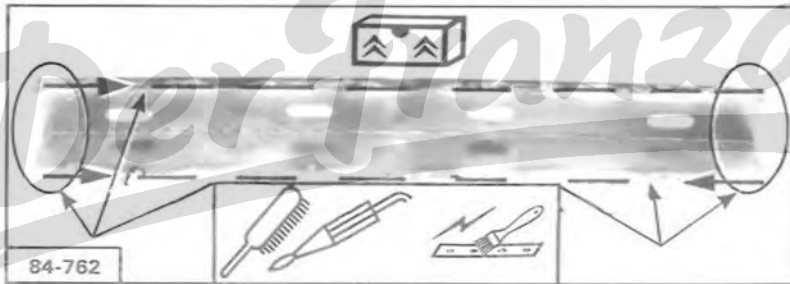
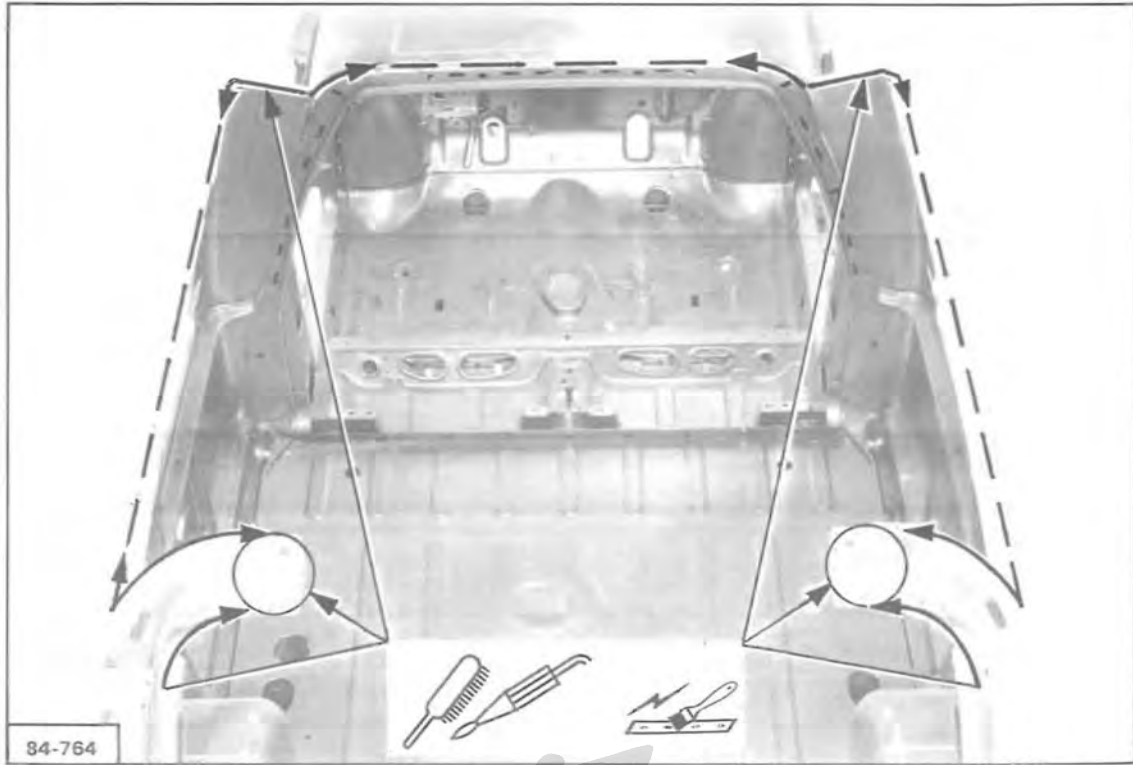

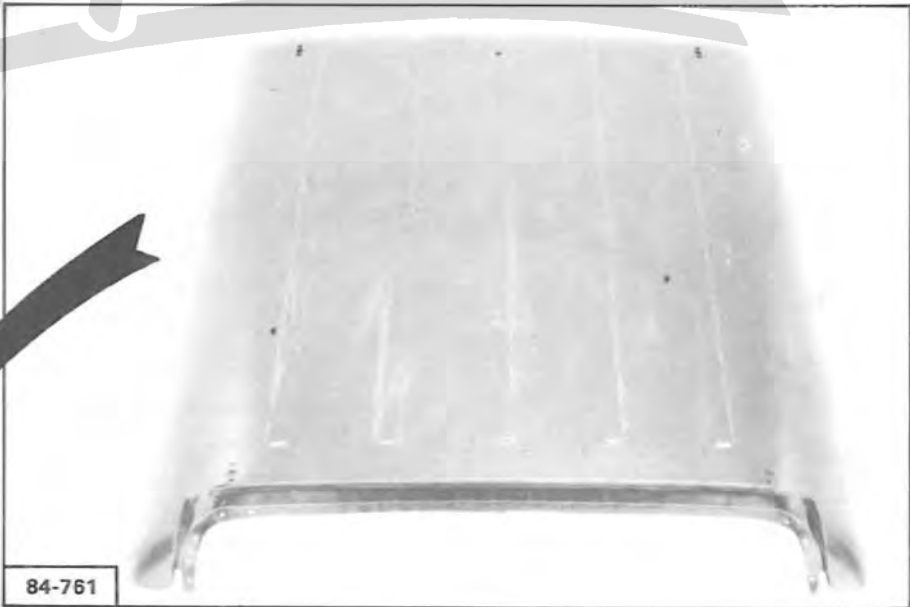
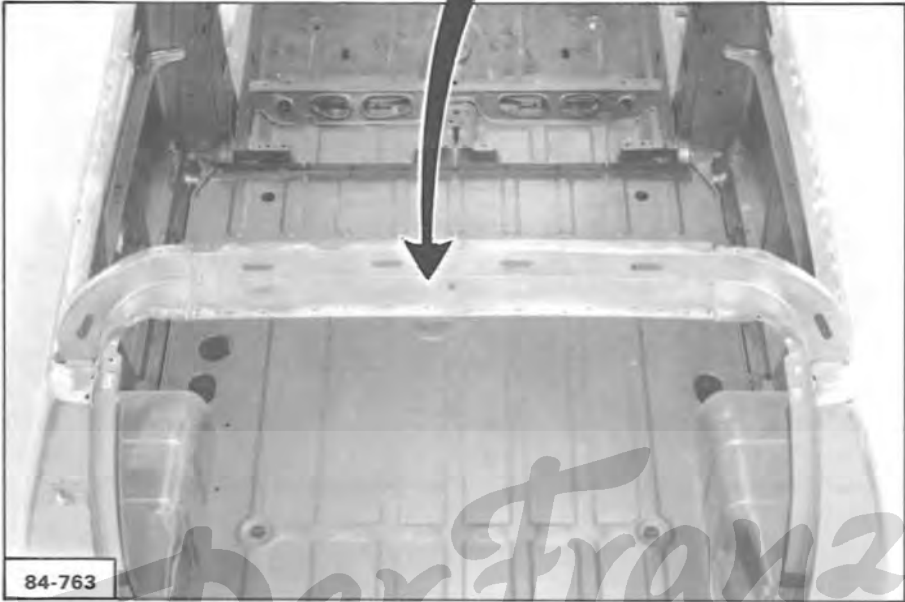
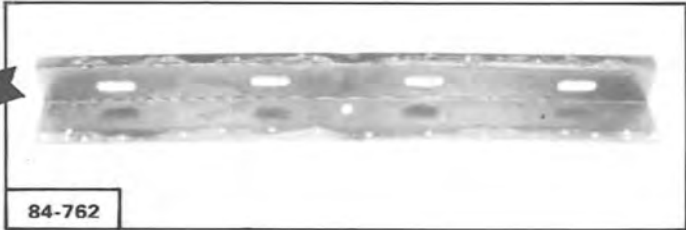

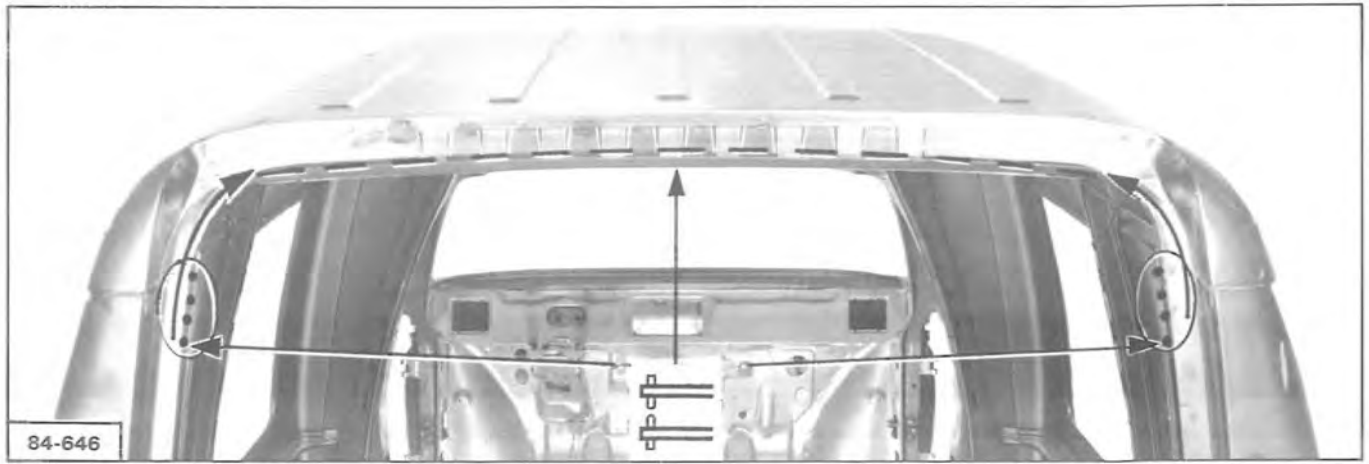
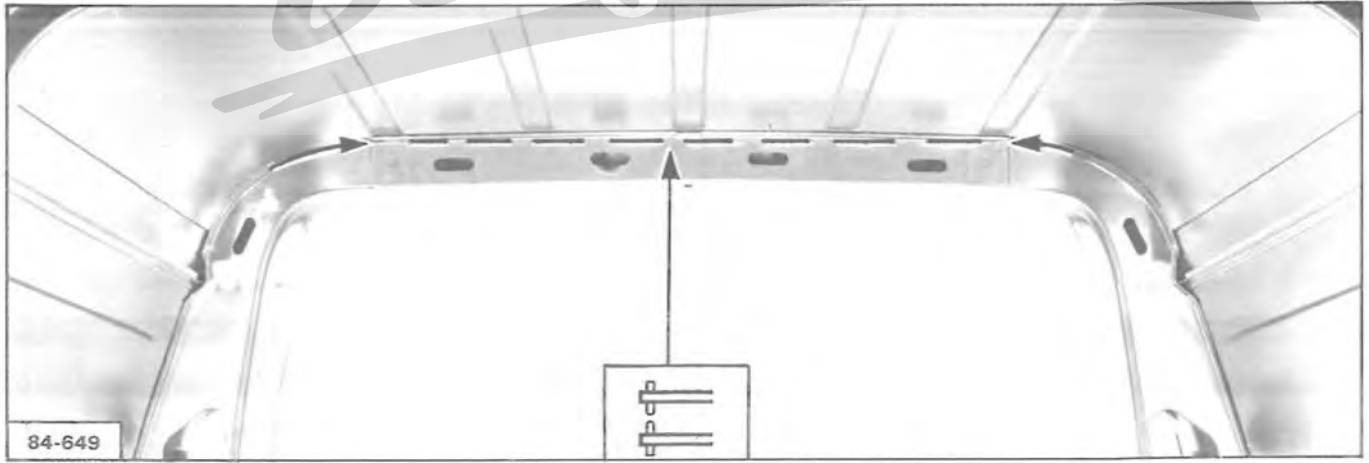
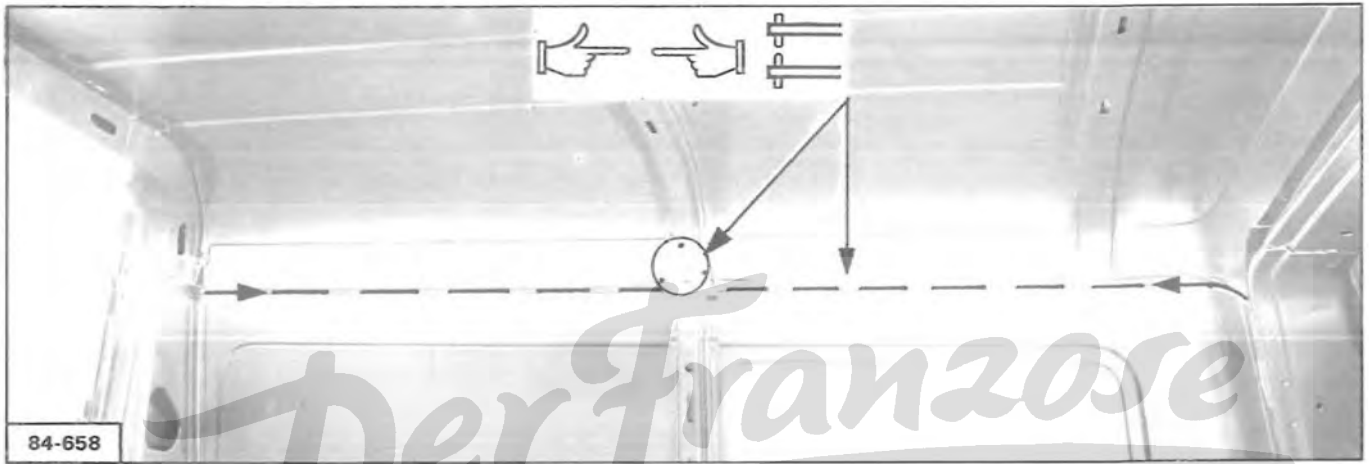
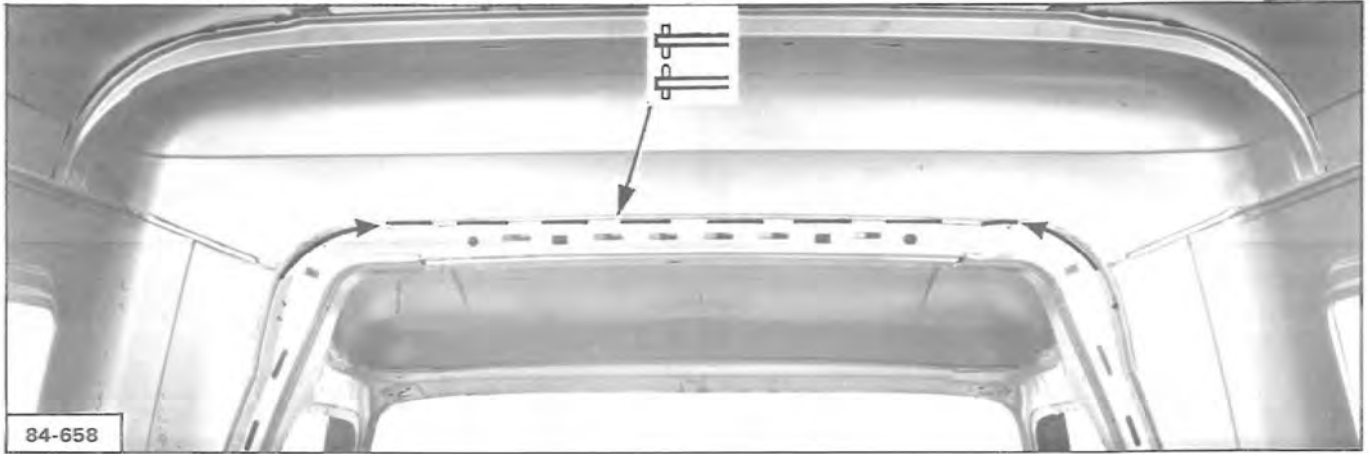

Der Franzose

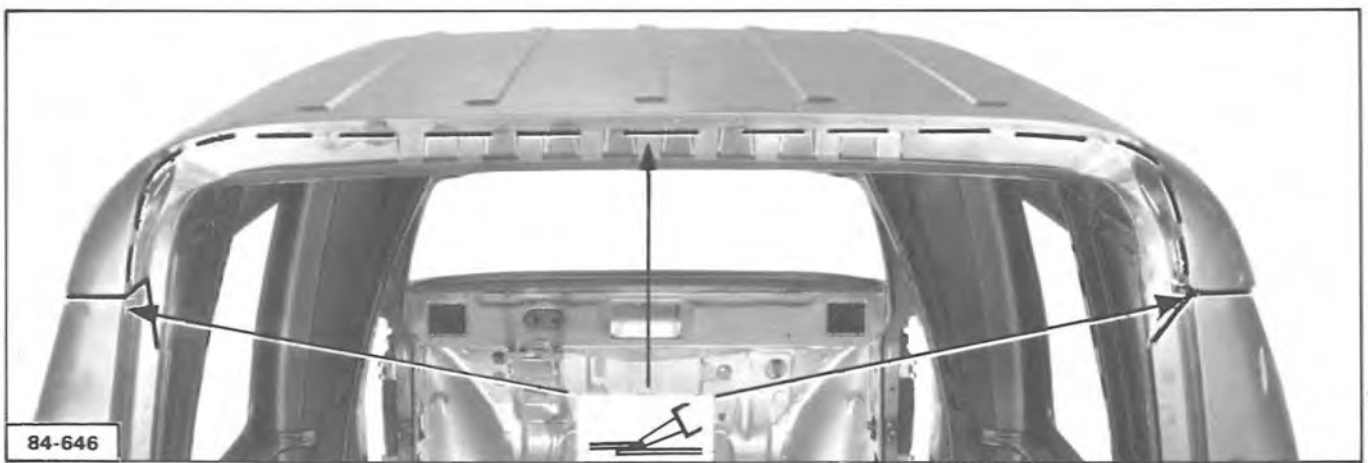
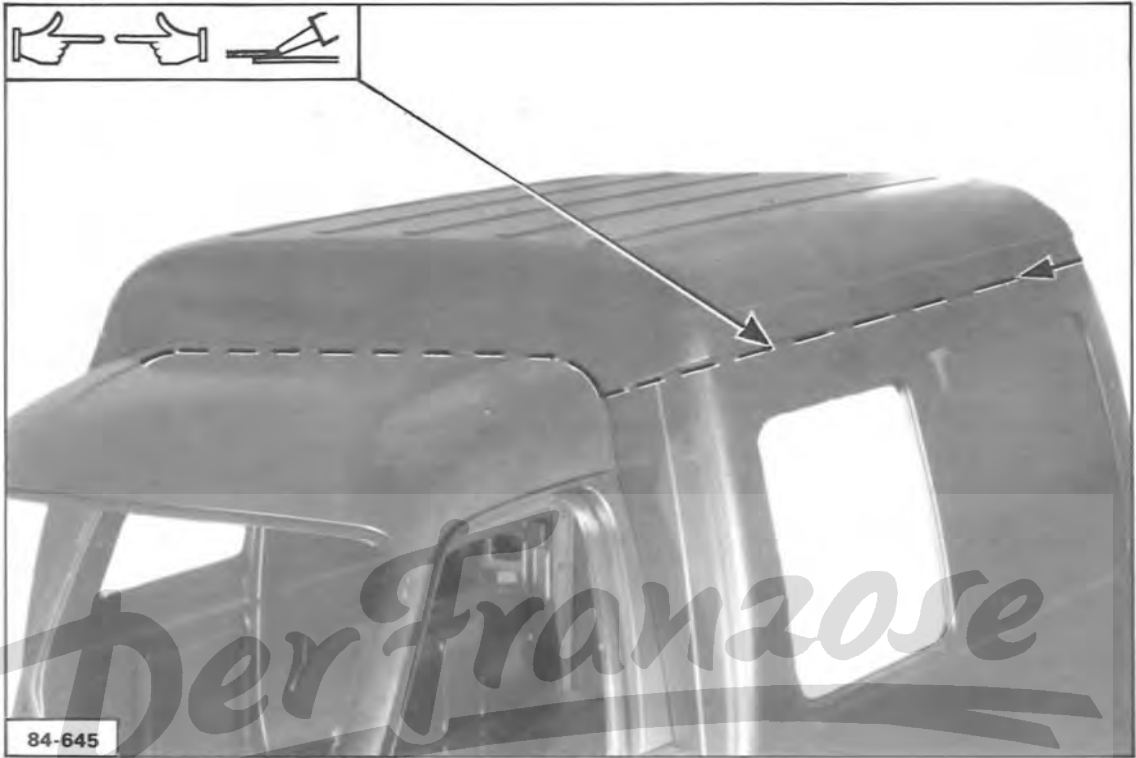

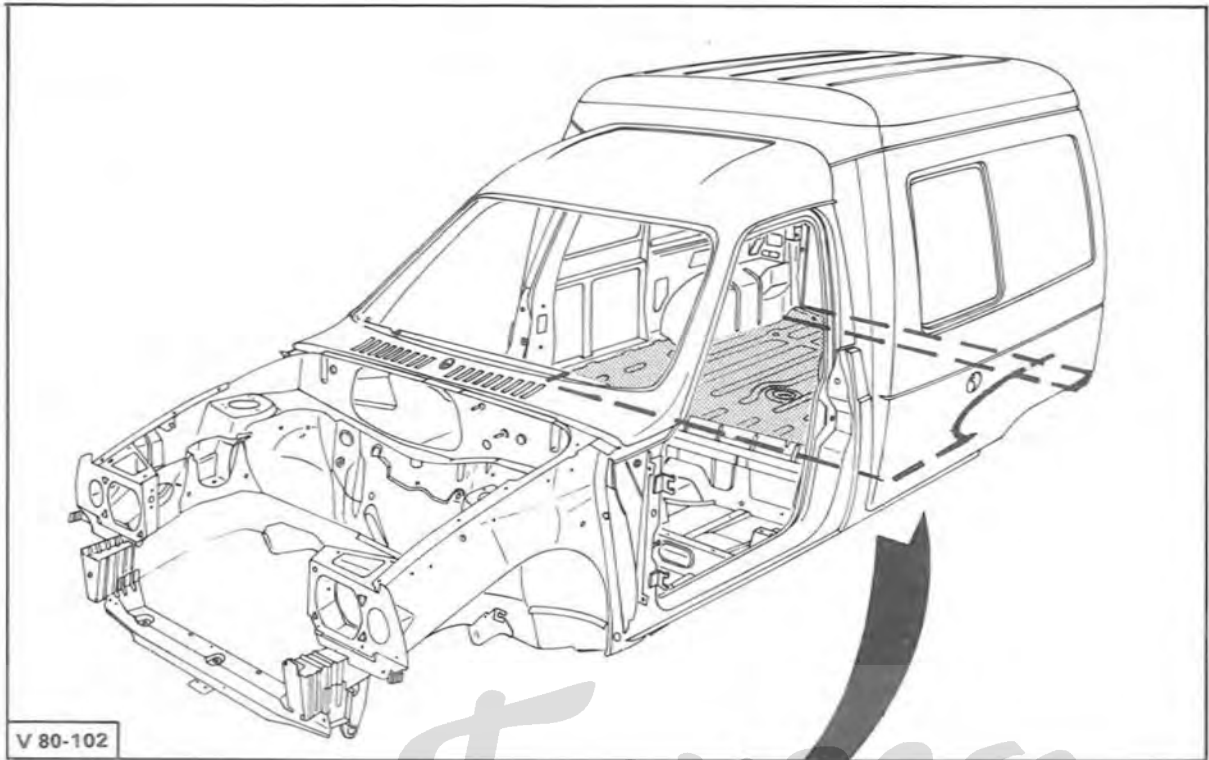

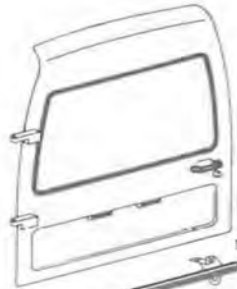
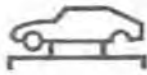

V 80-73 V 80-121

Der Franzose

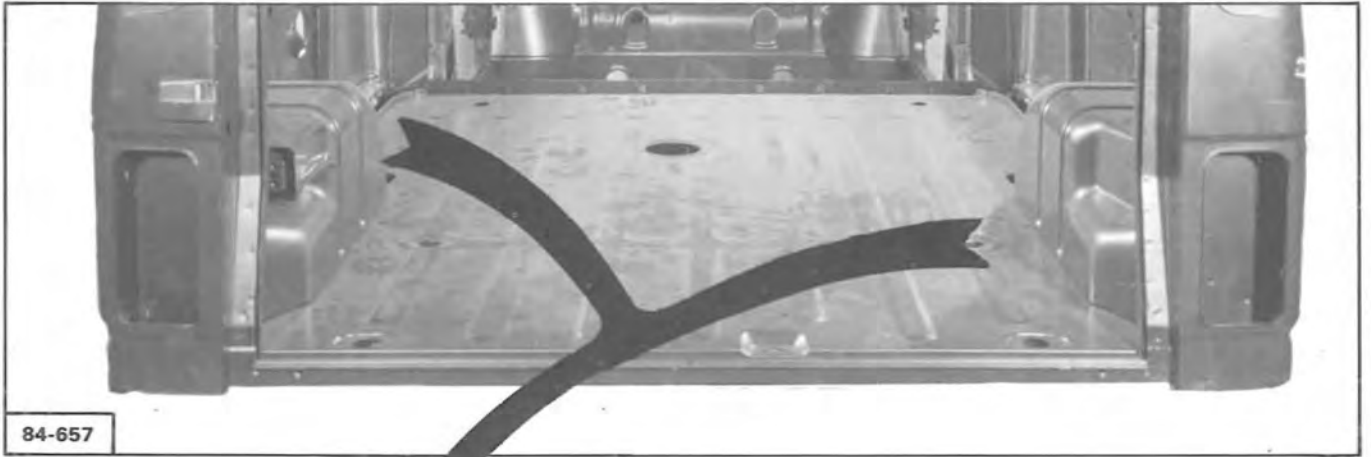

84-657

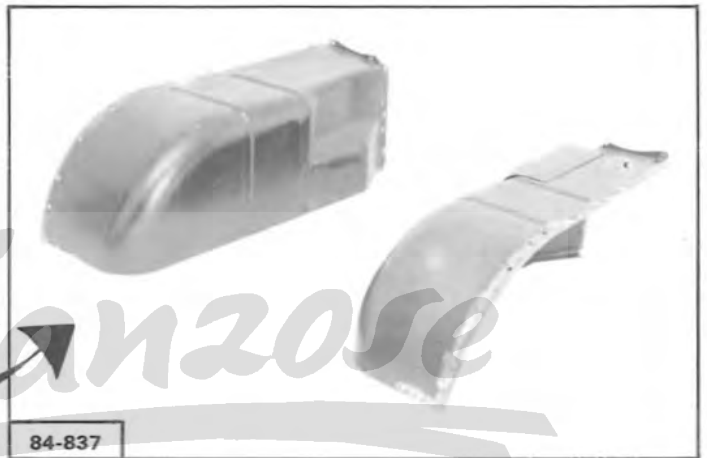
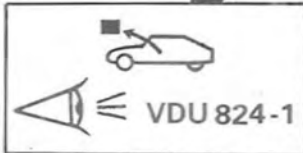

84-837

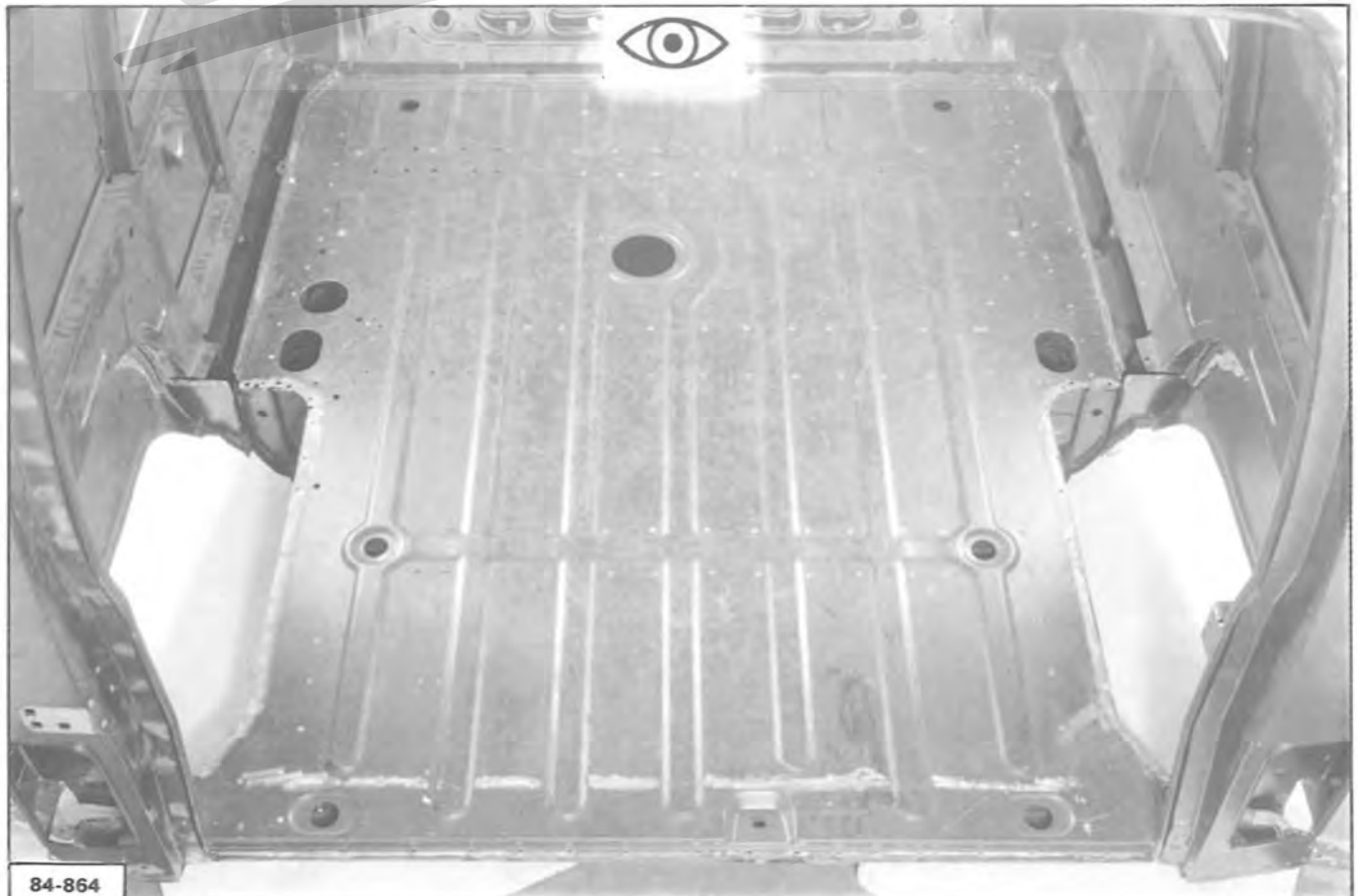

84-864

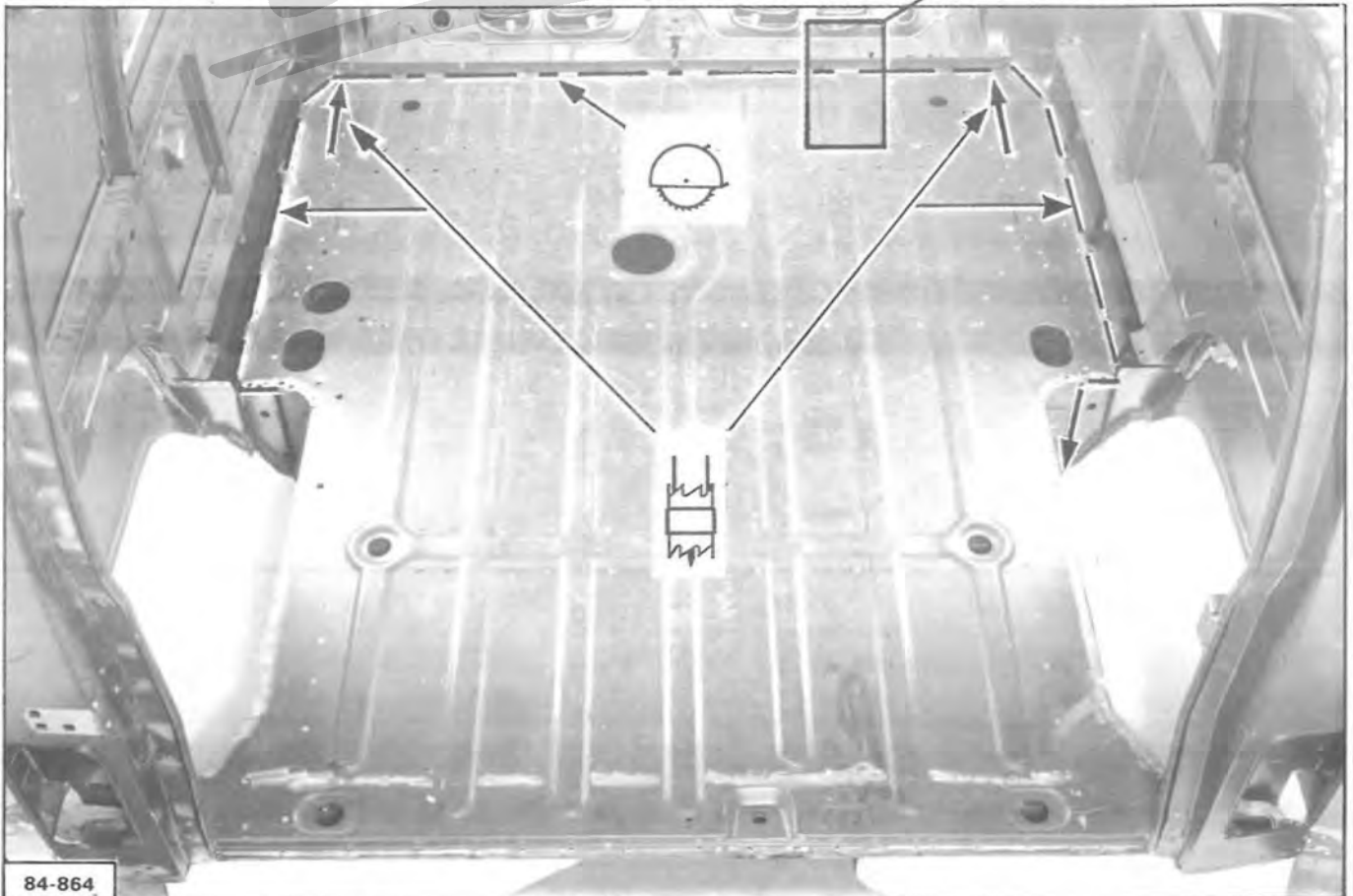
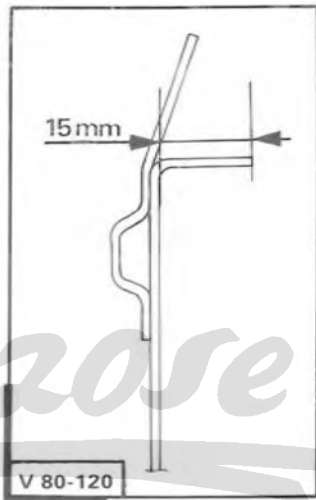
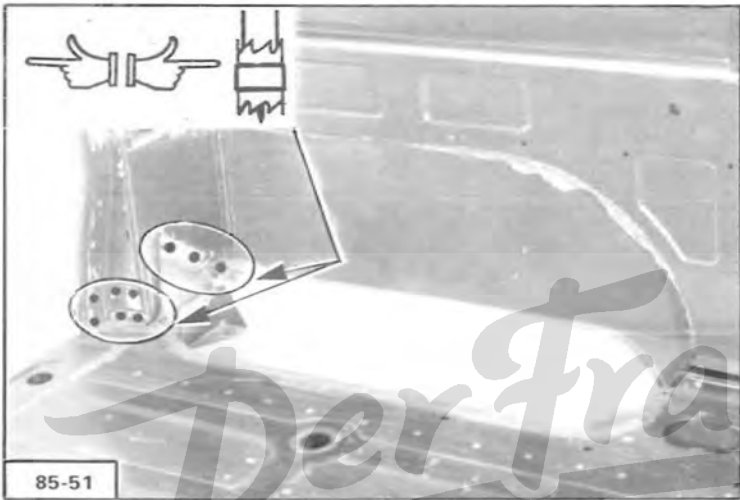
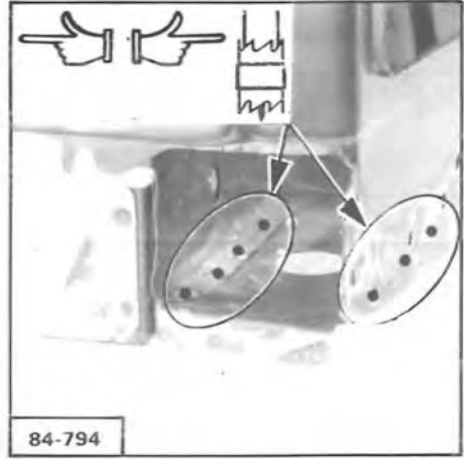
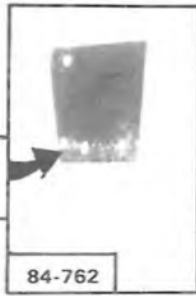
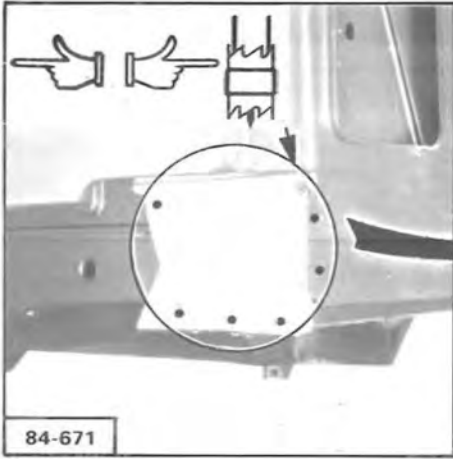
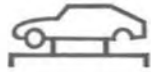

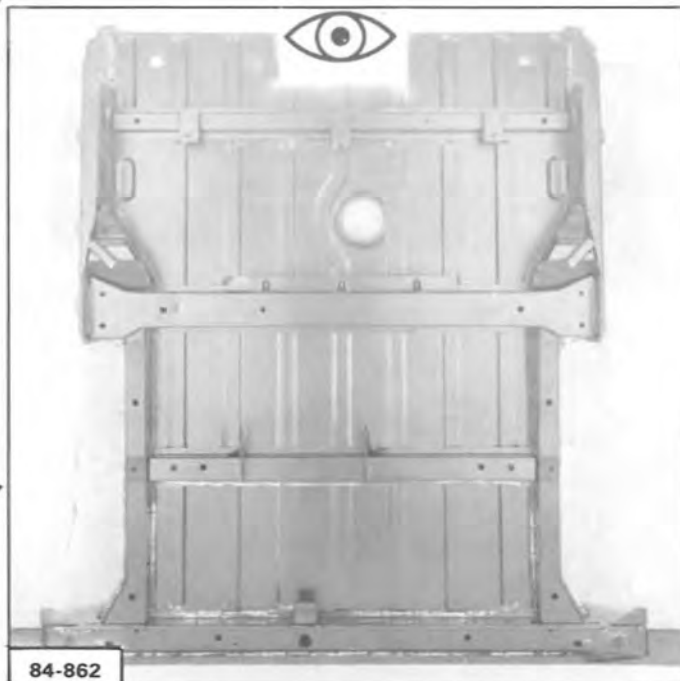
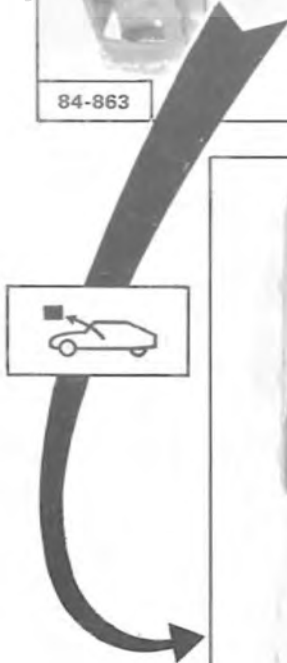
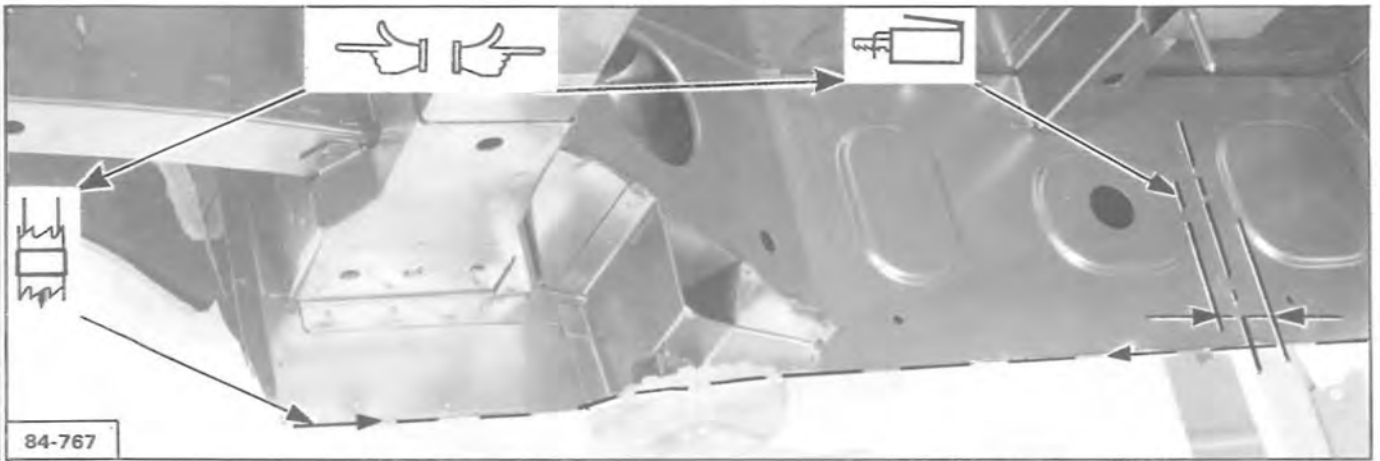



84-867

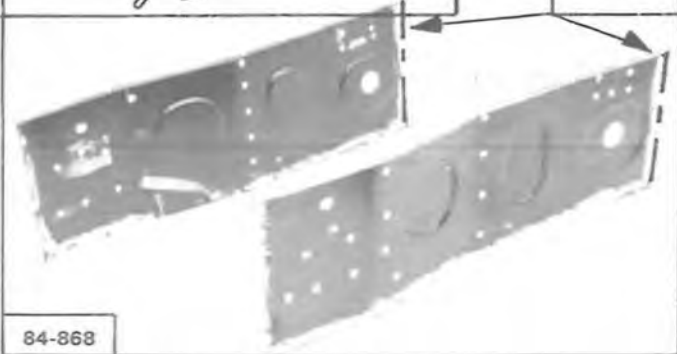

84-868

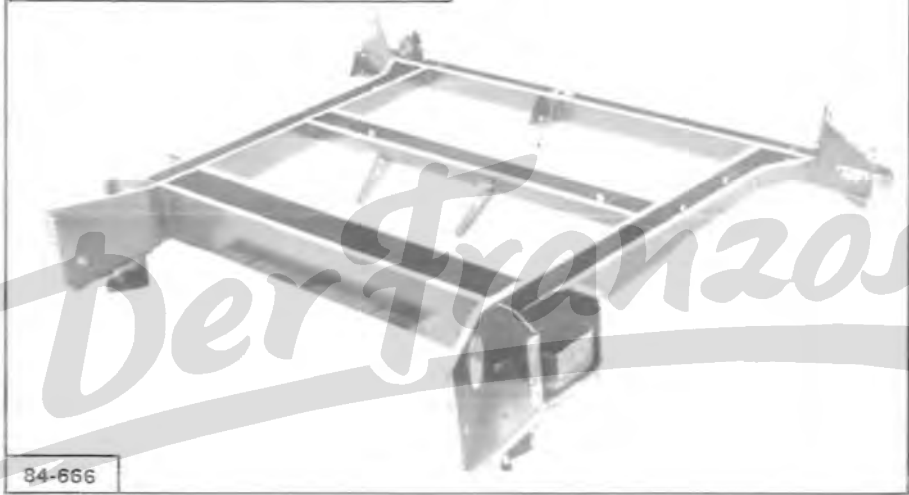

84-666

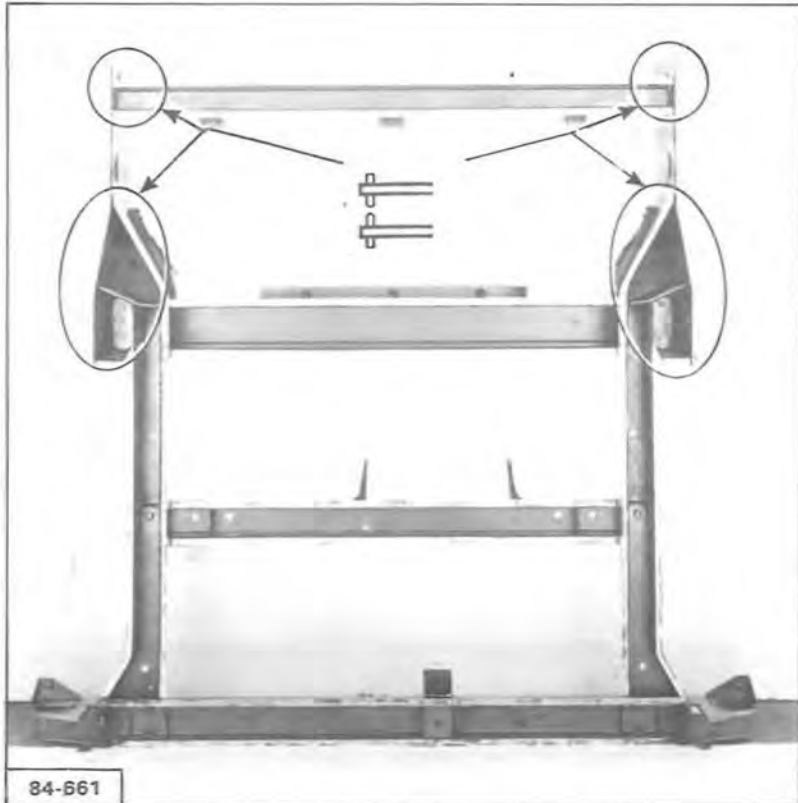

84-661

Der Franzose

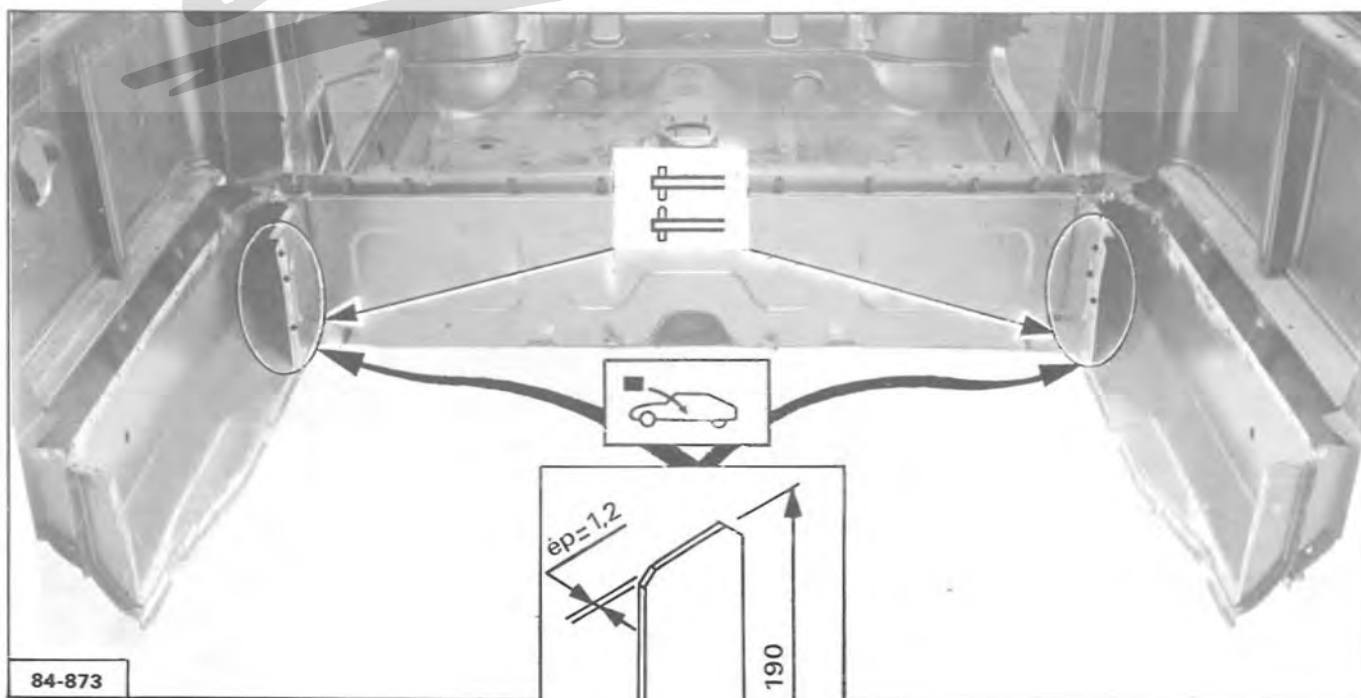

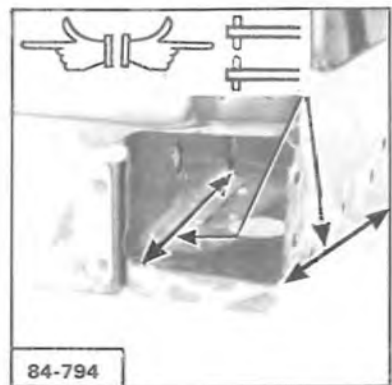
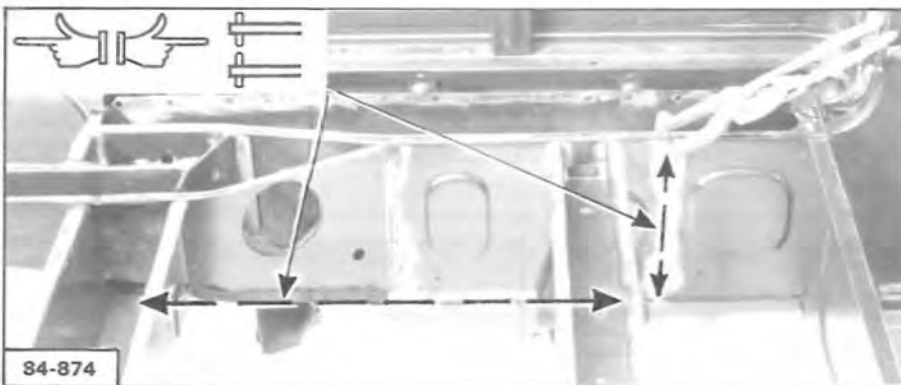
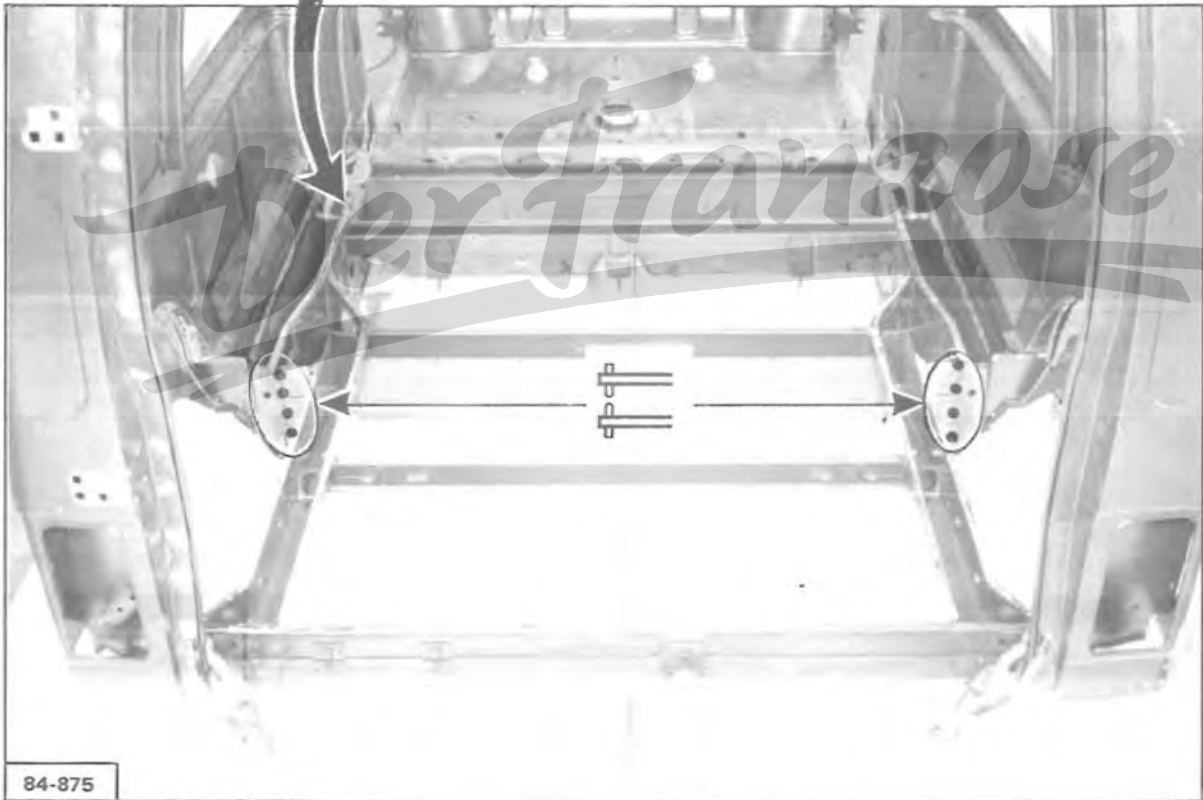
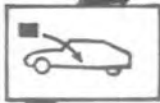
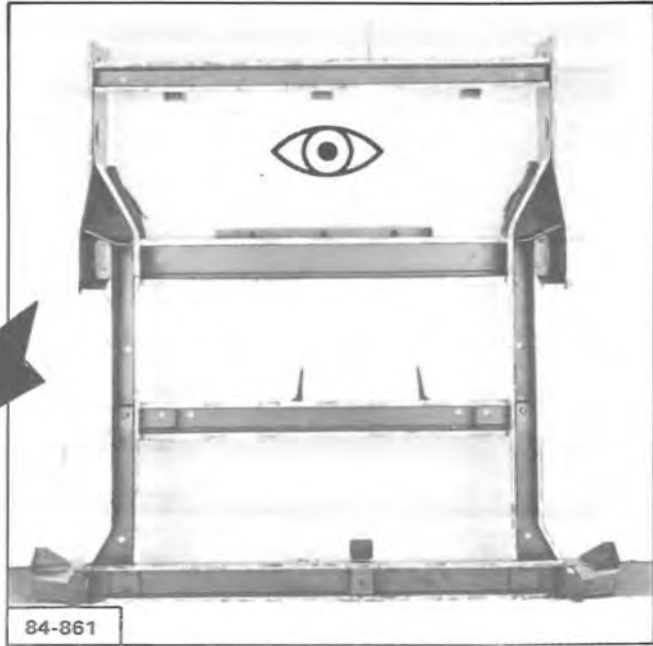

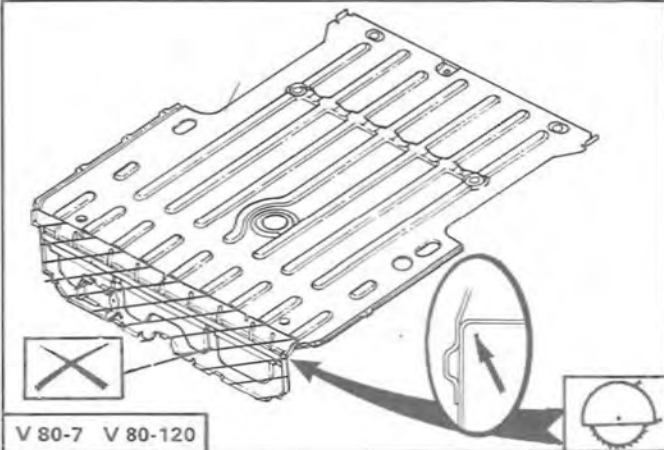

V 80-7 V 80-120

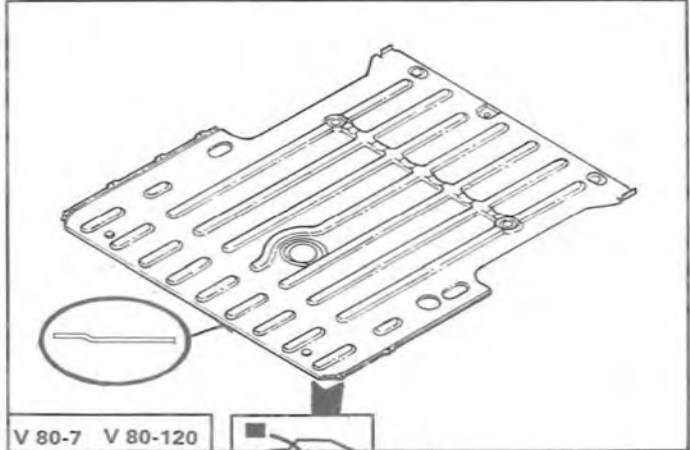

V 80-7 V 80-120



84-864

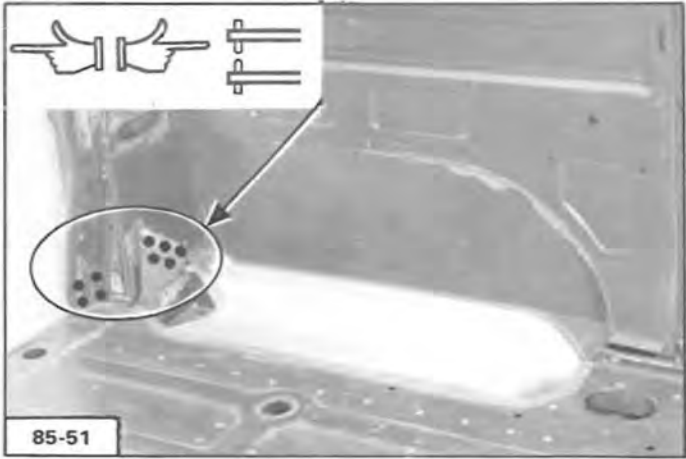

85-51

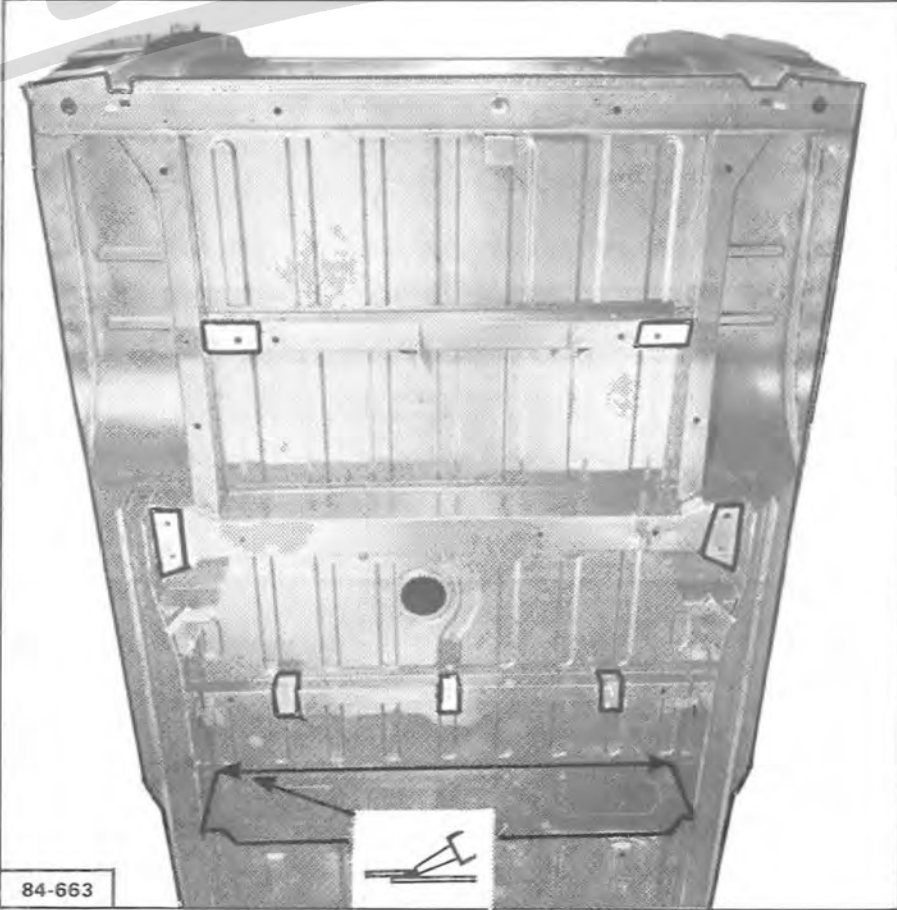
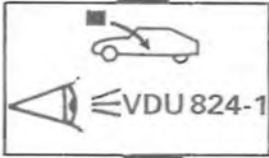
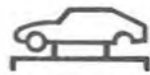

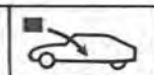

V 80-73

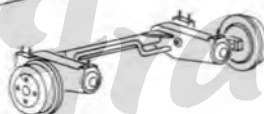

V 80-121 V 80-73

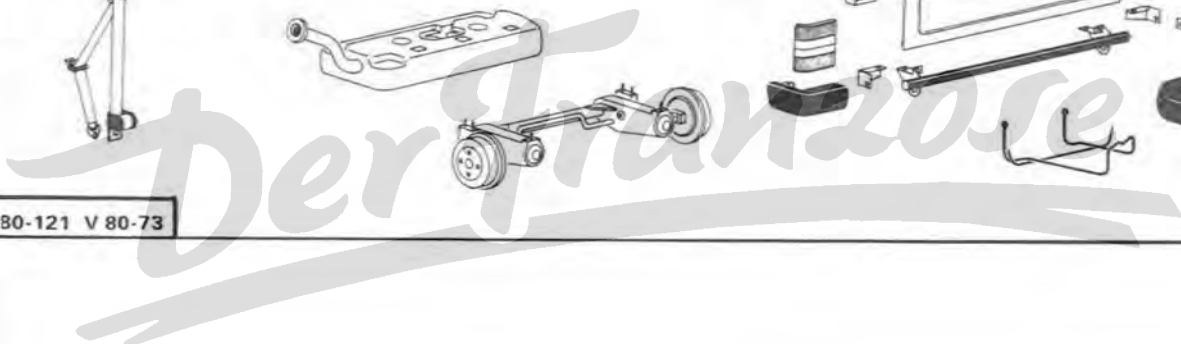

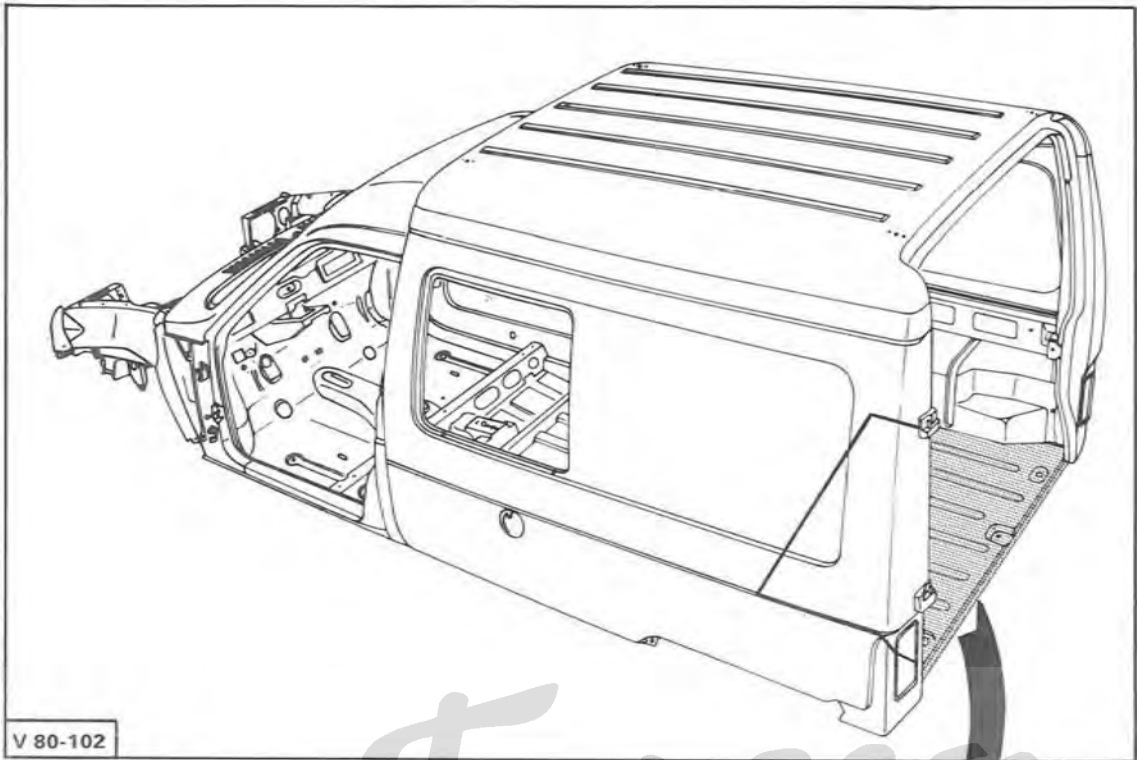
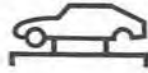

V 80-102

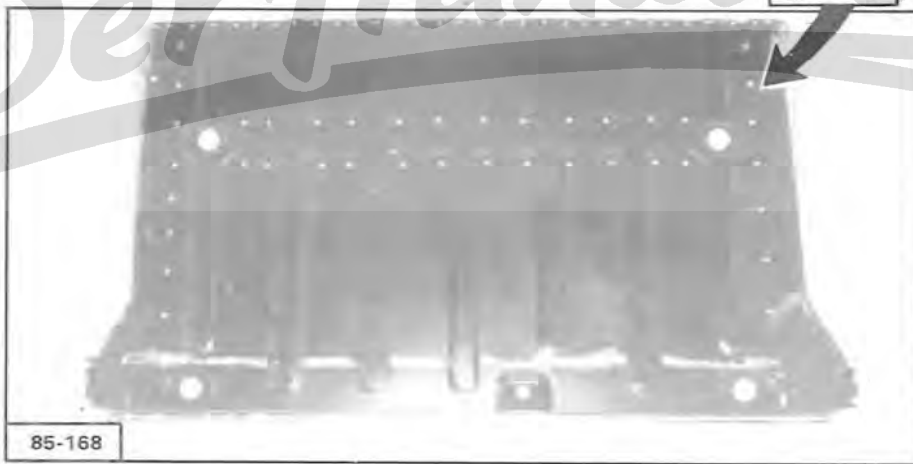

85-168

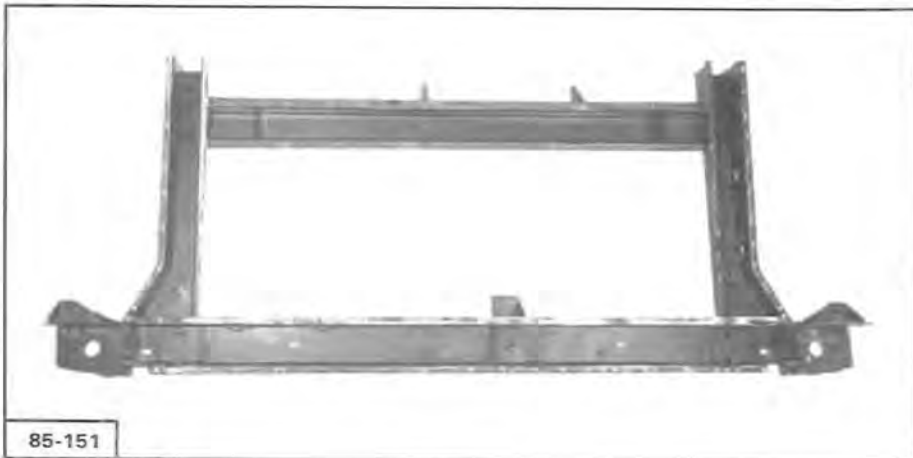

85-151

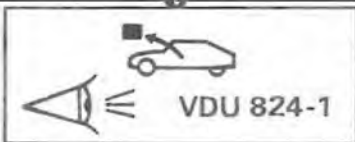
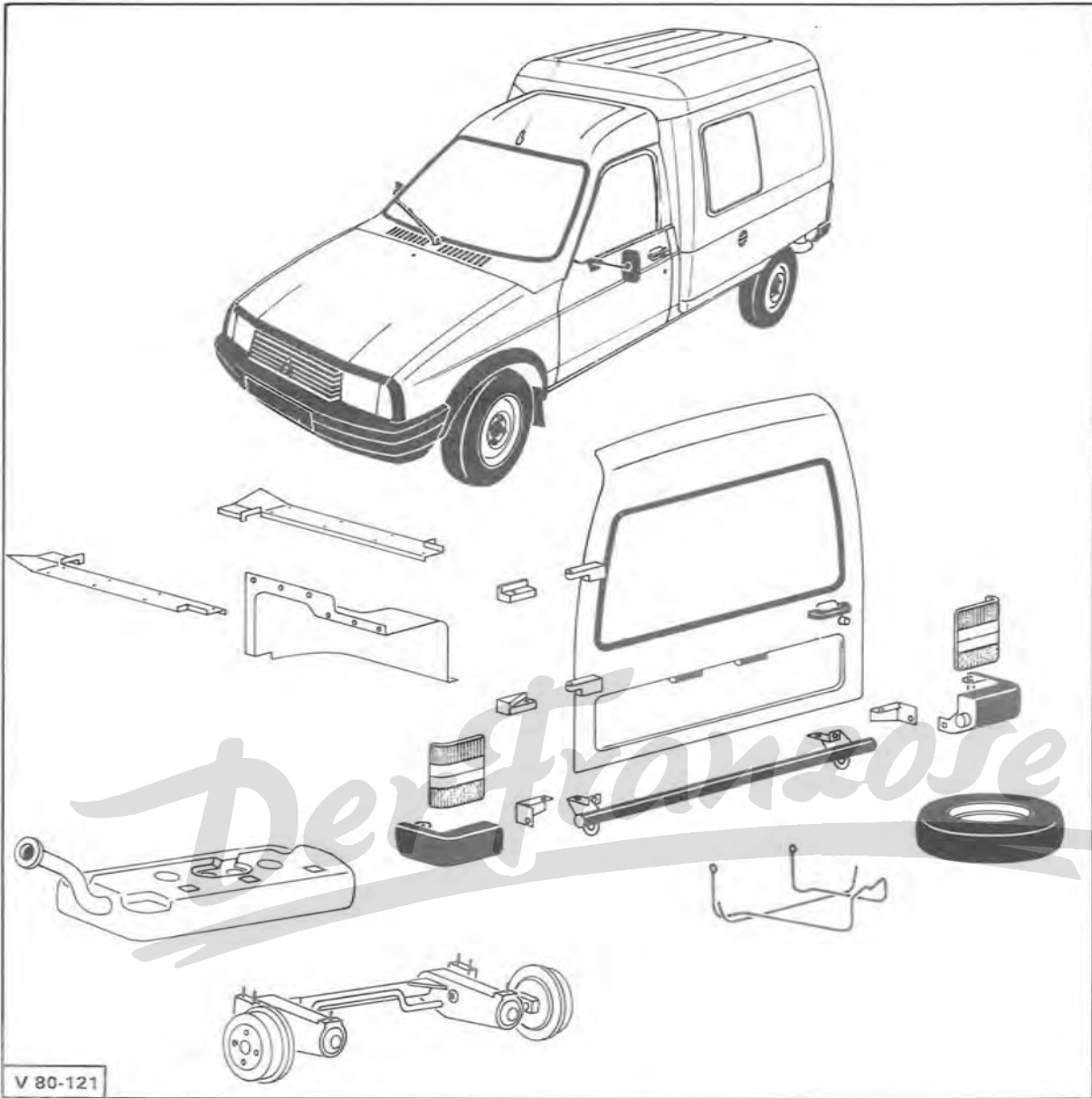

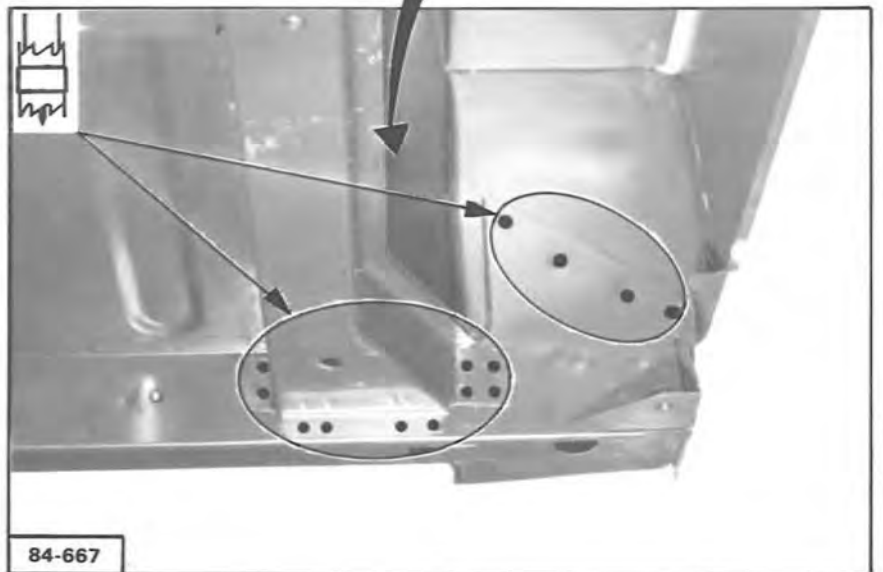
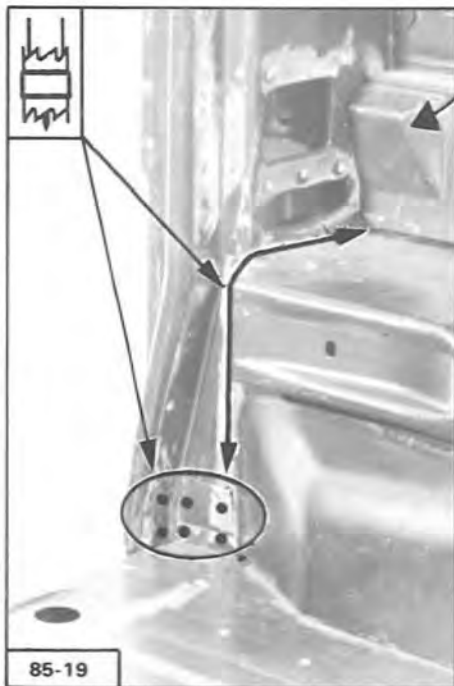
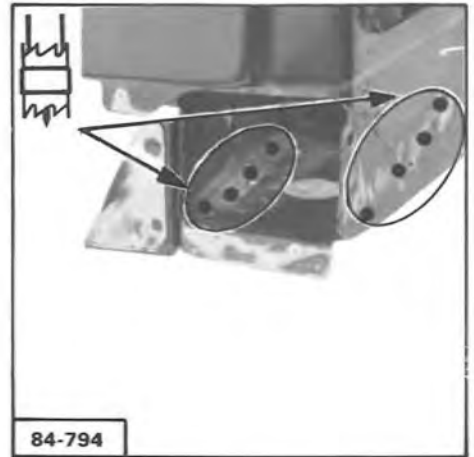
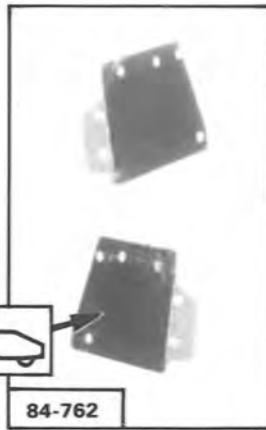
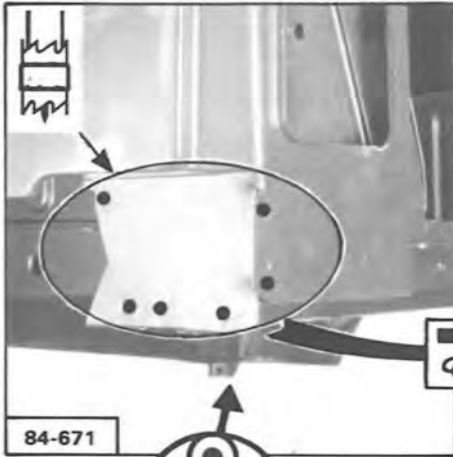

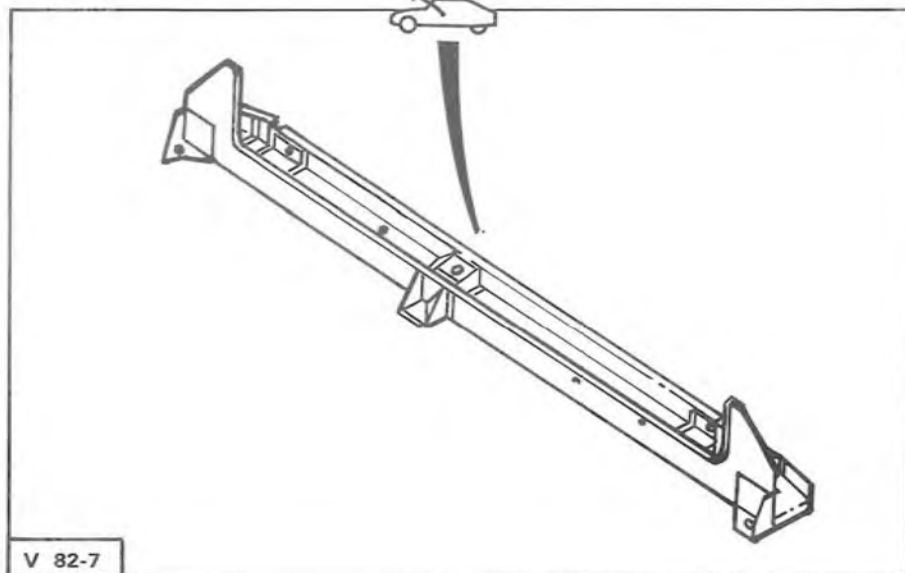
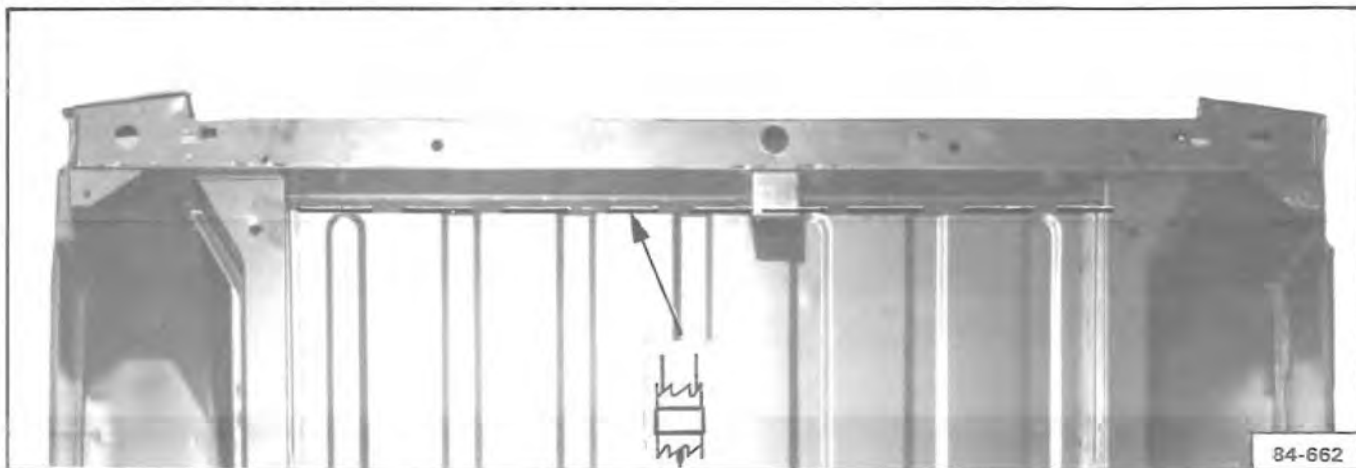

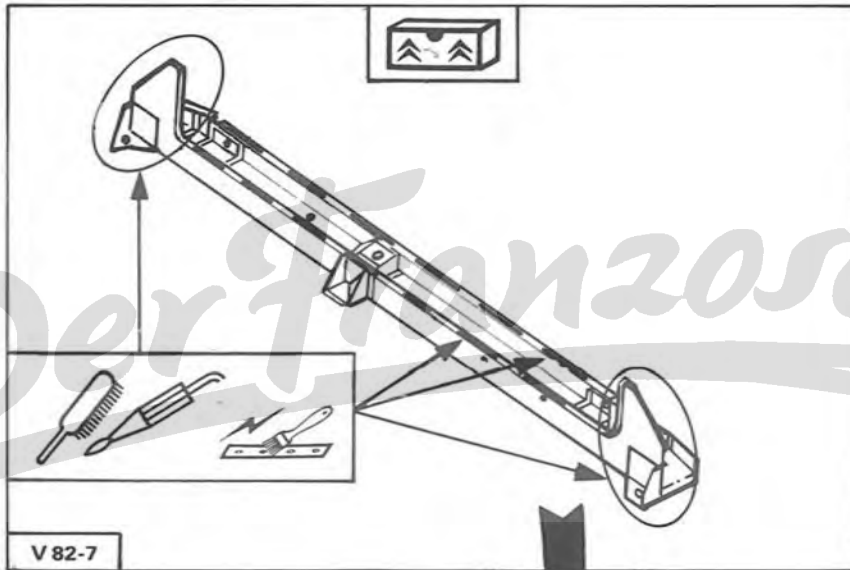
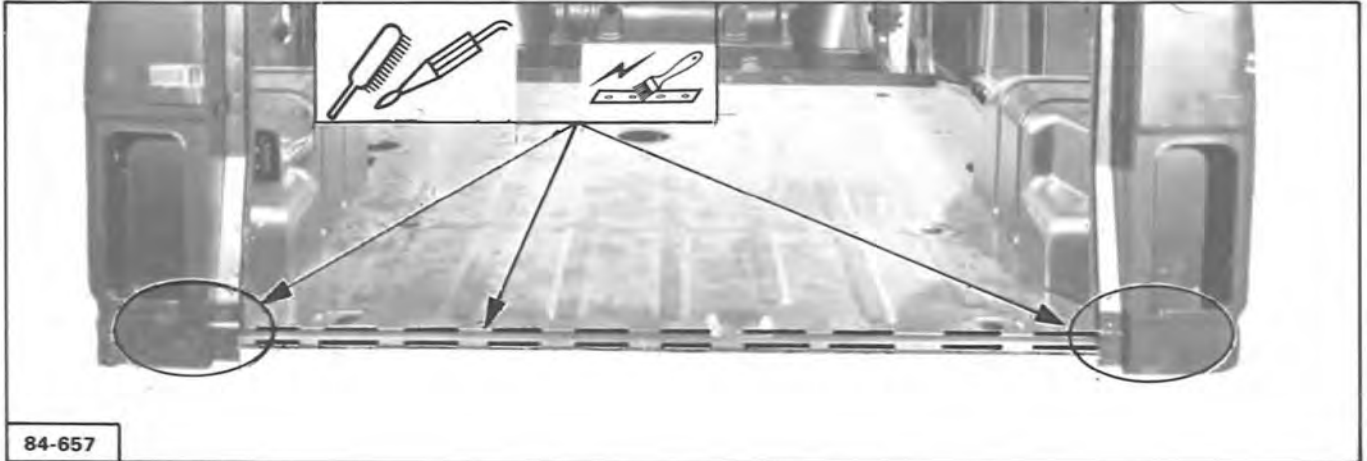

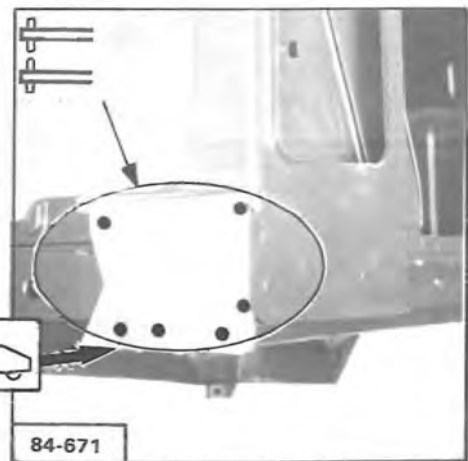
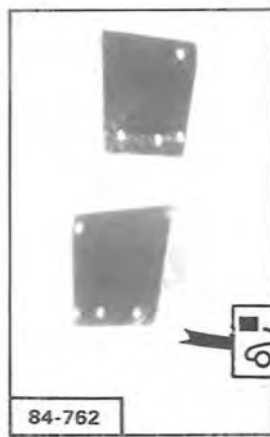
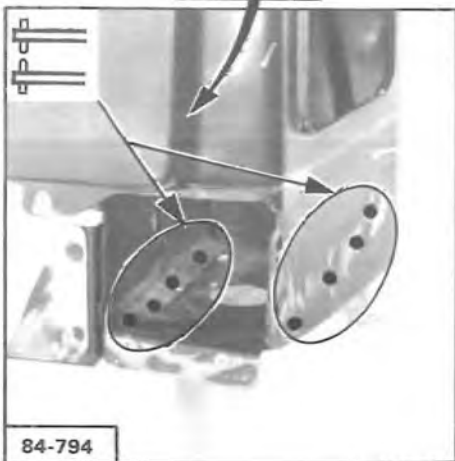
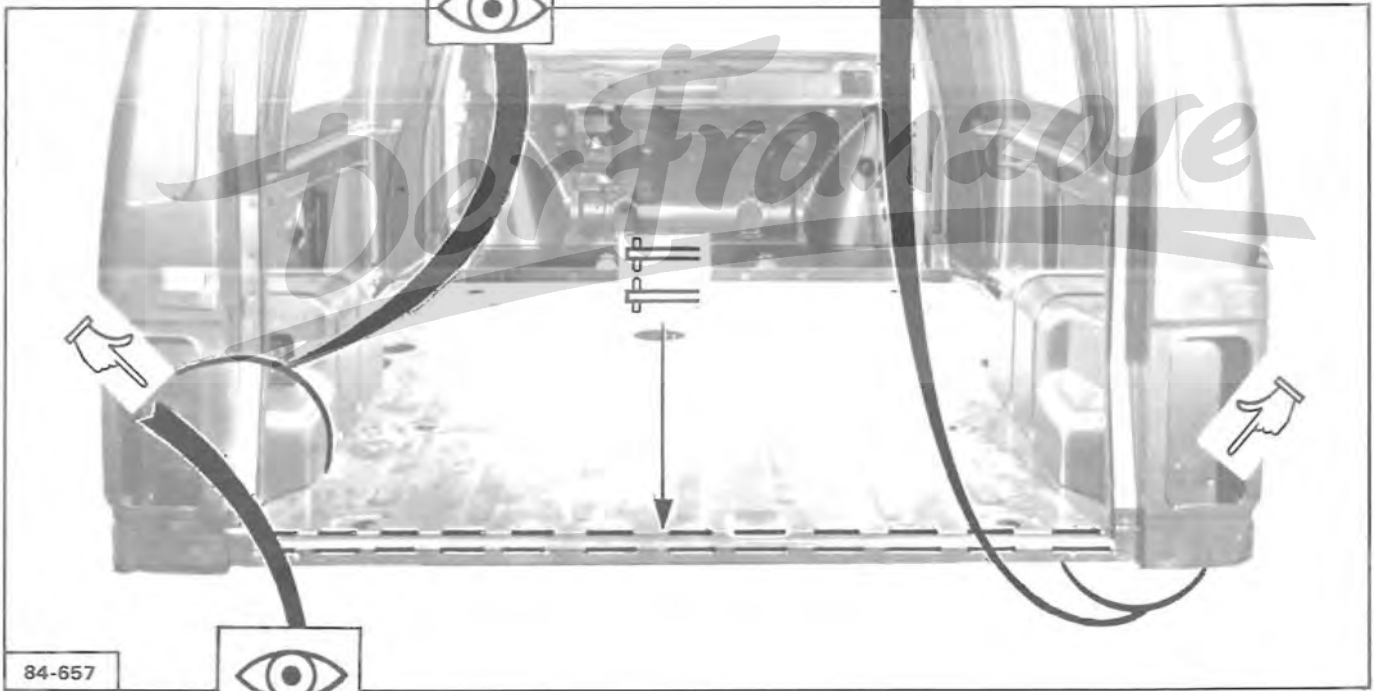
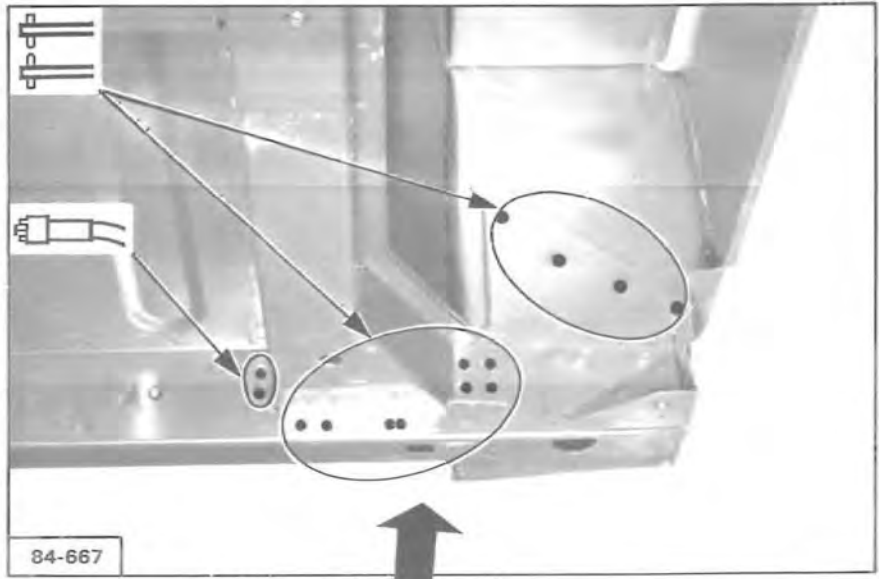
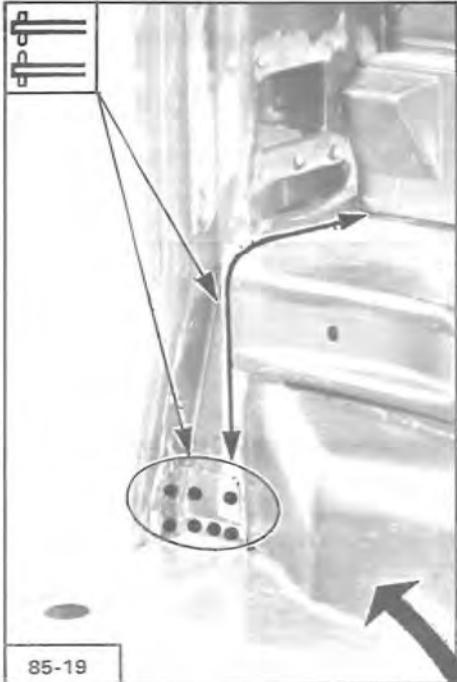

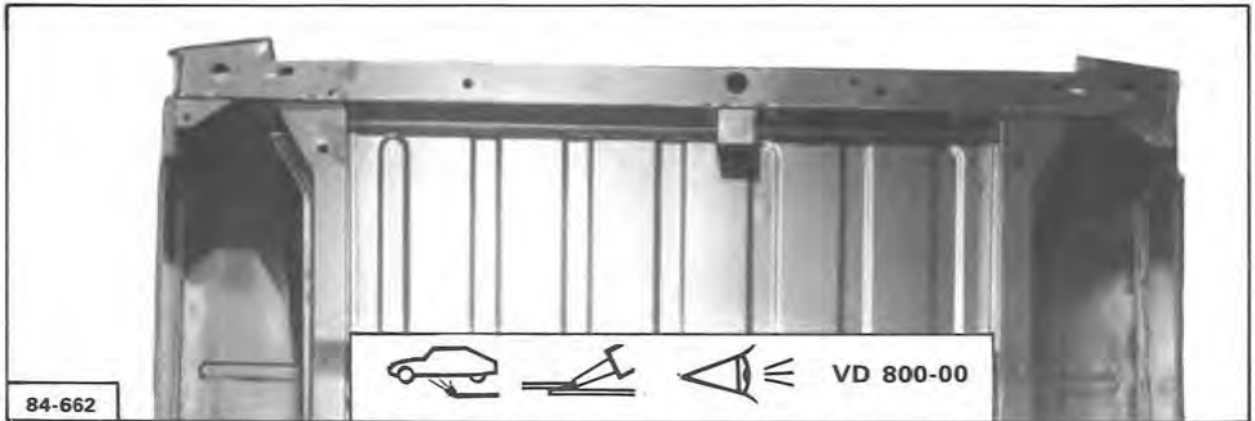

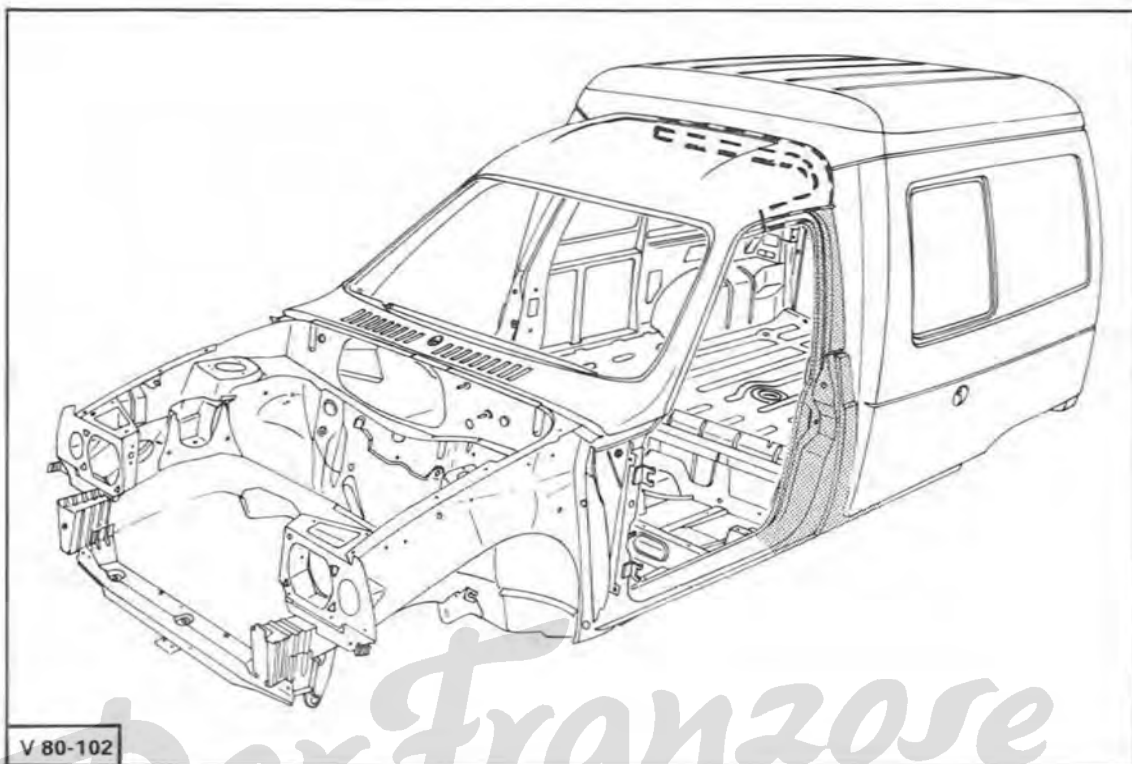

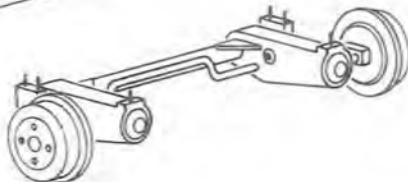
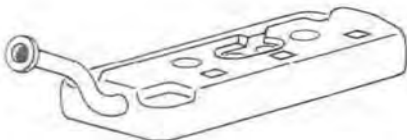
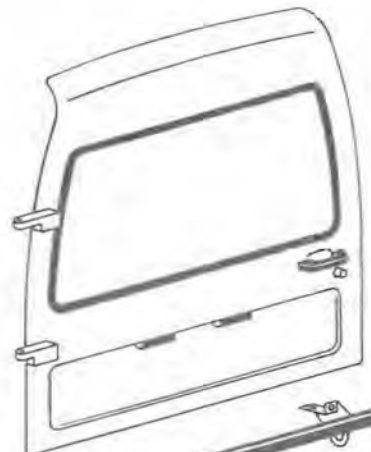
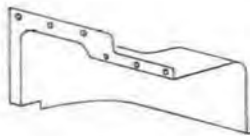
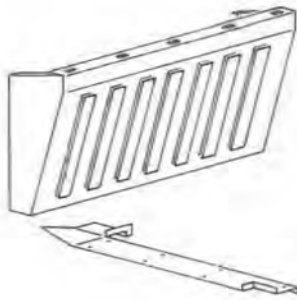
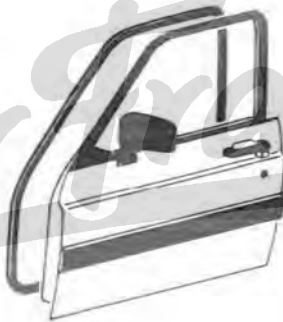
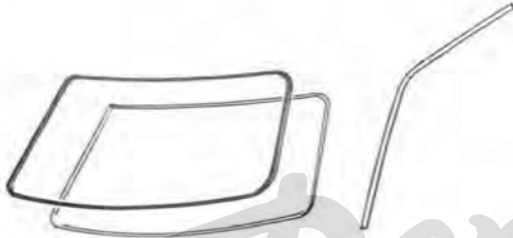
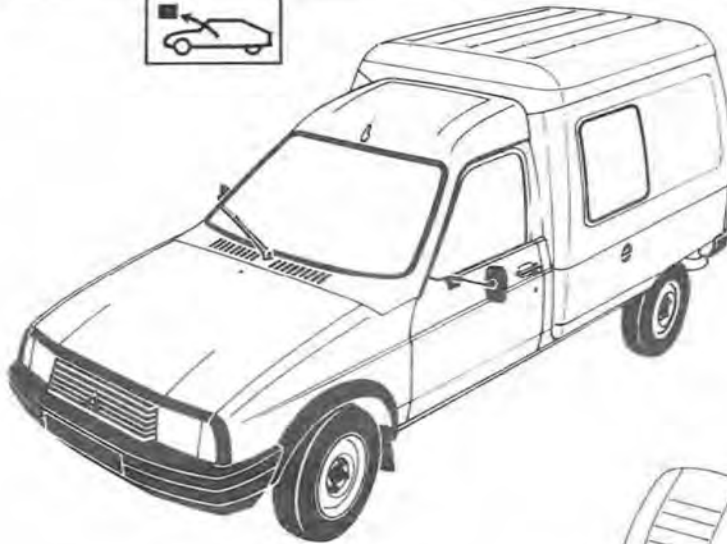
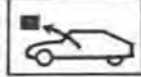

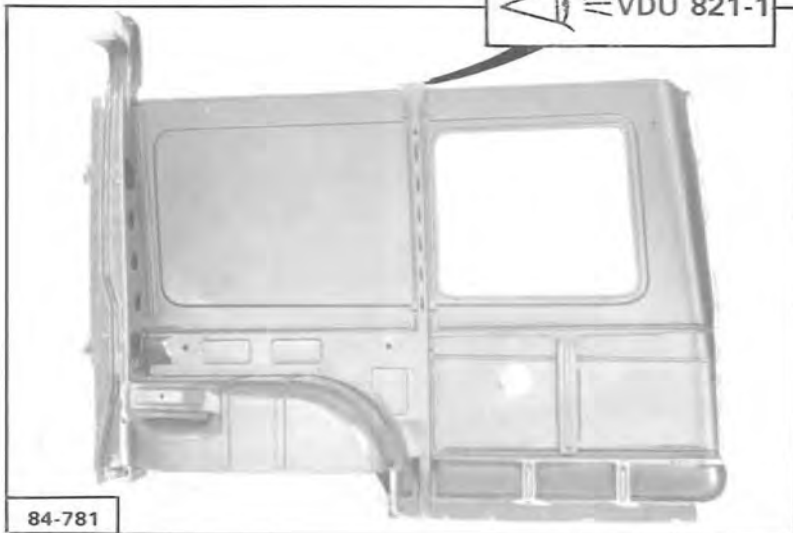
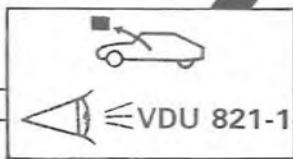
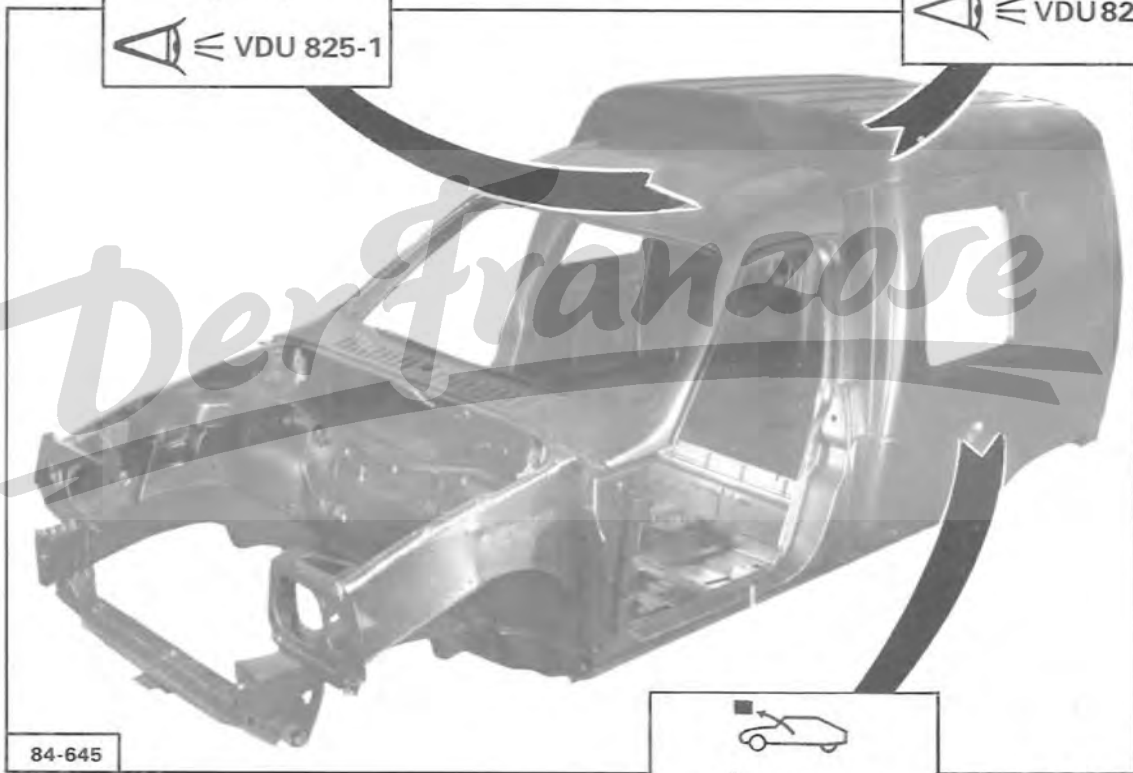
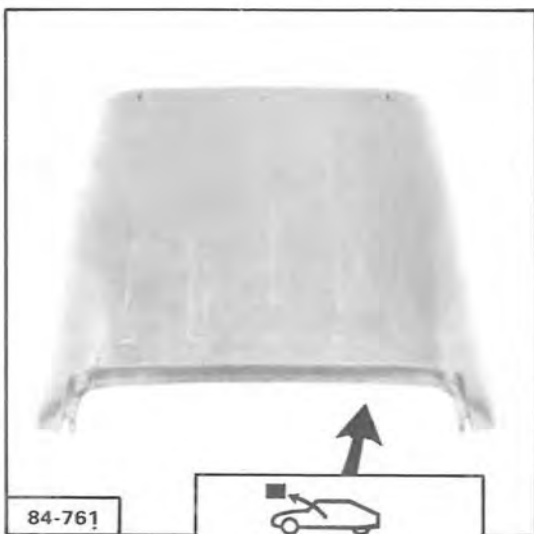
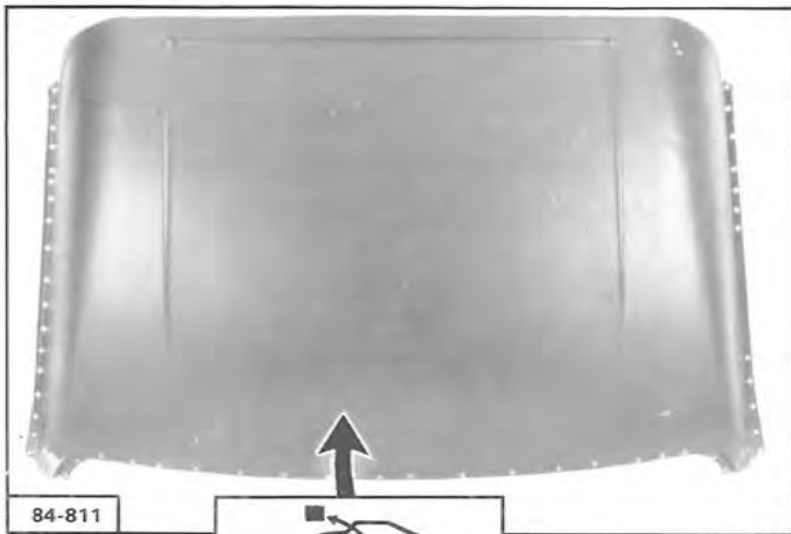

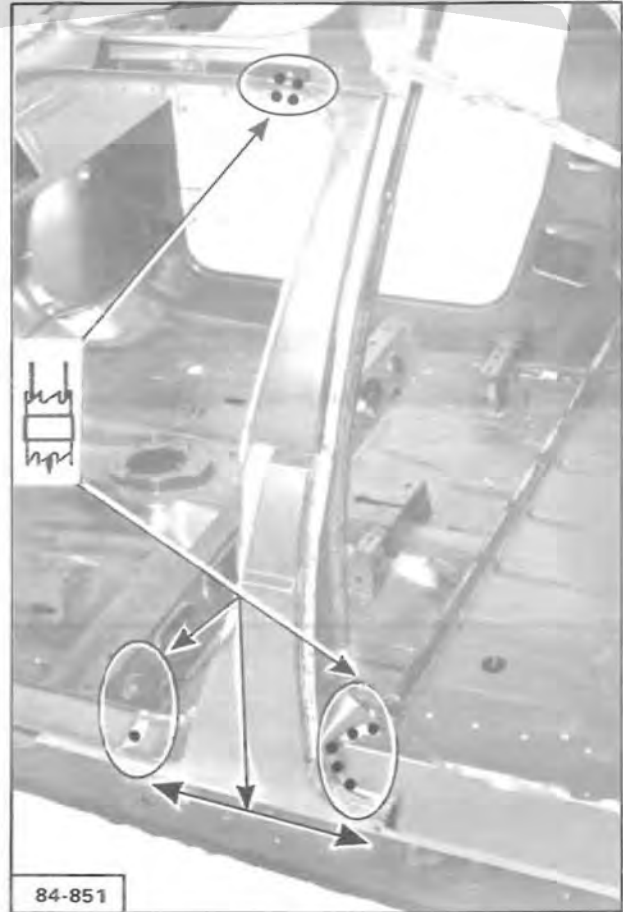
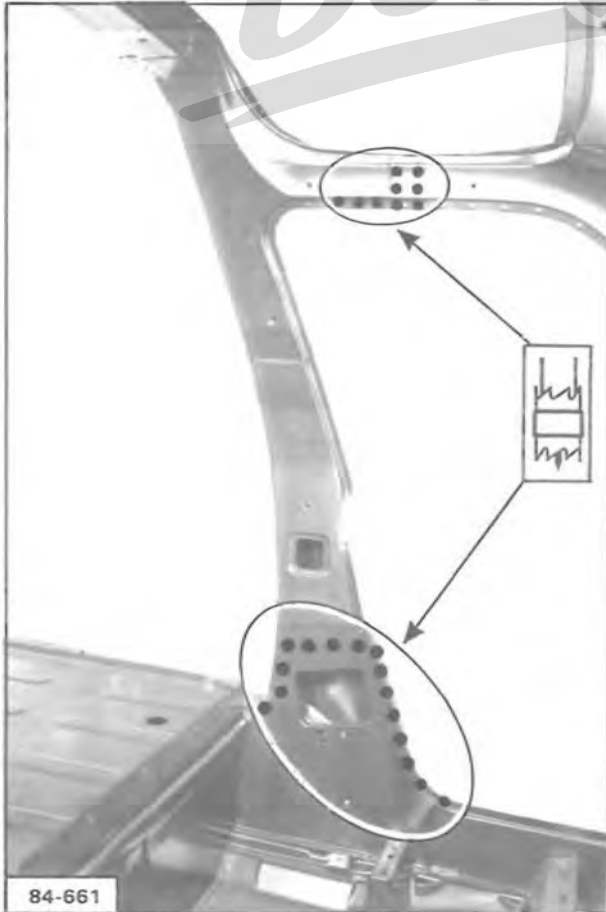
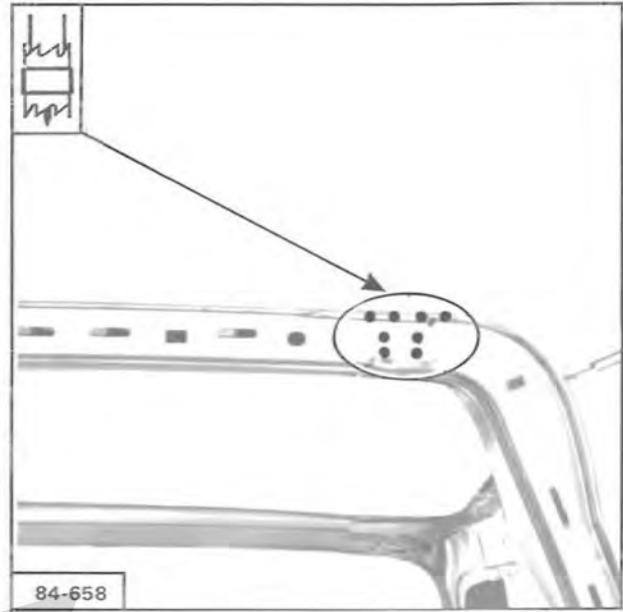
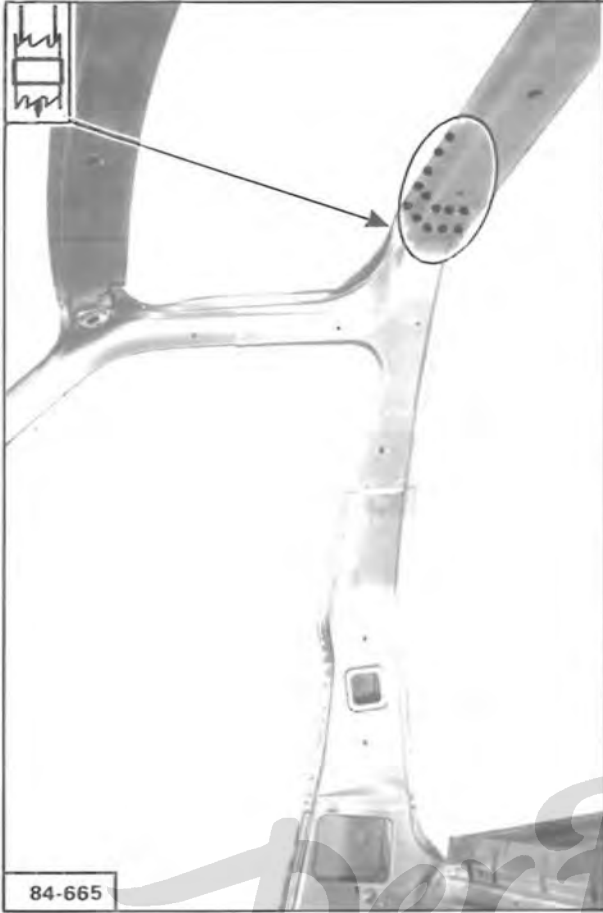

Der Franzose

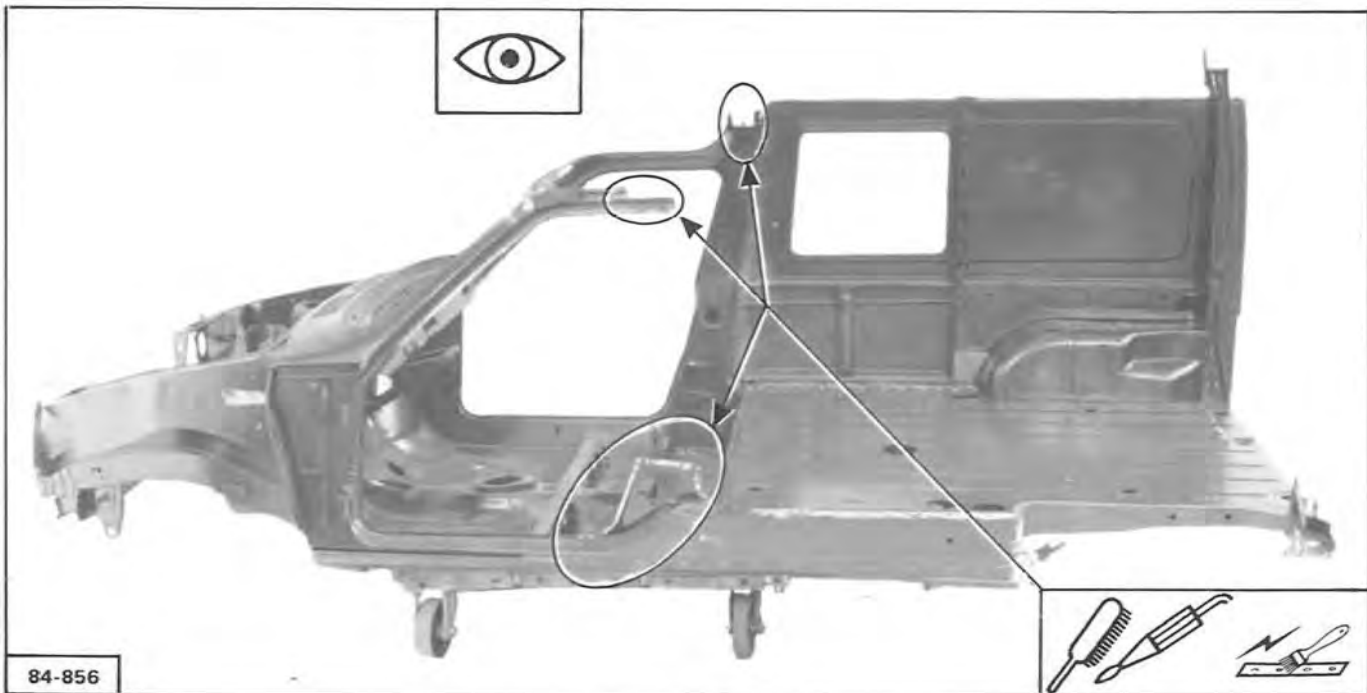

84-856

Der Franzose



84-857



84-817

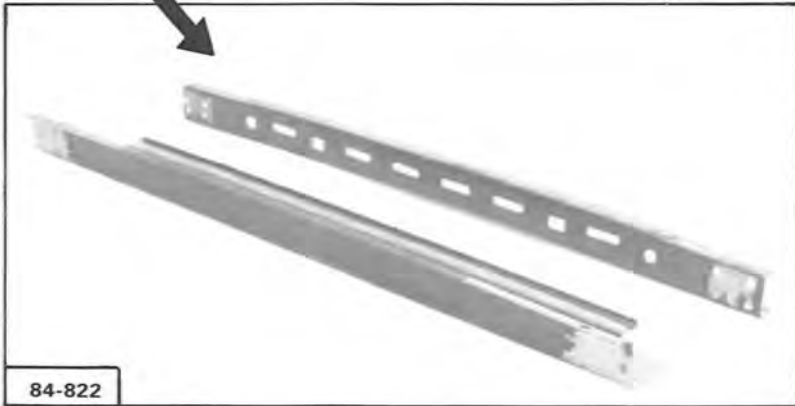

84-822

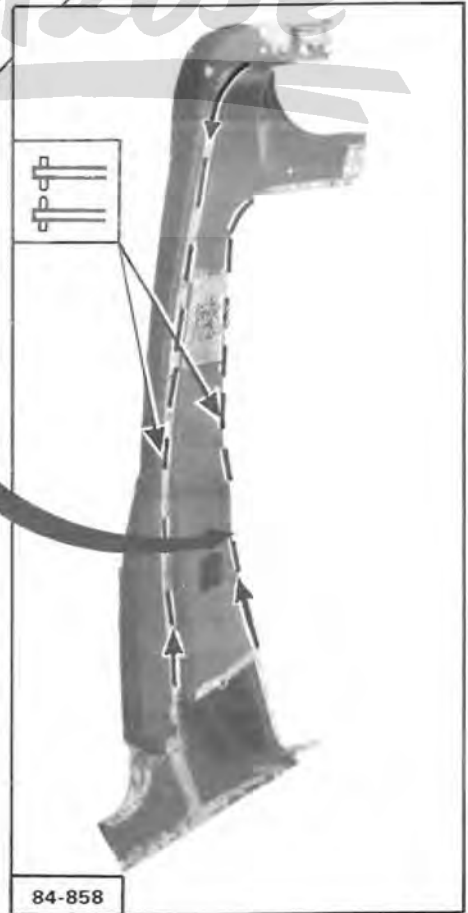
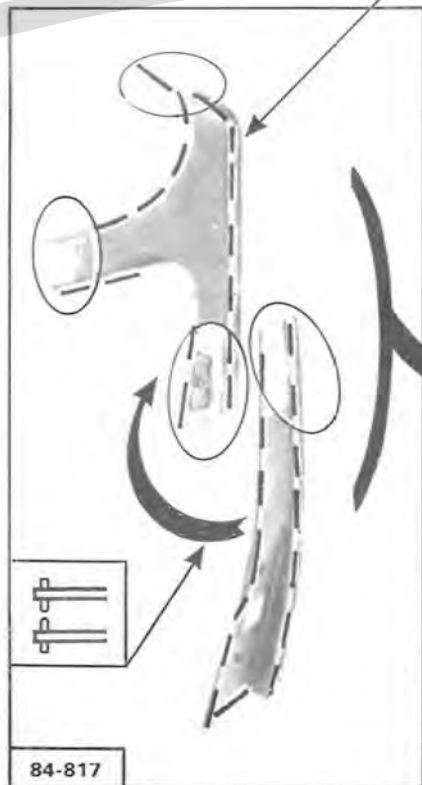
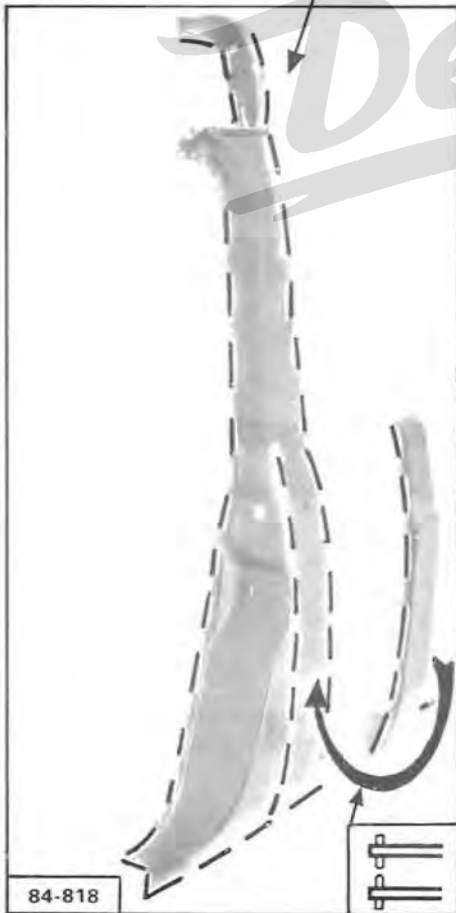
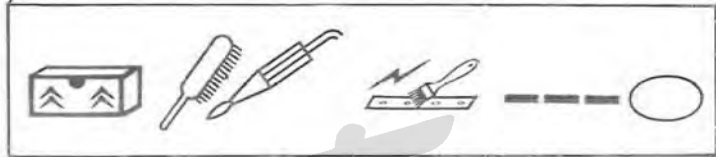
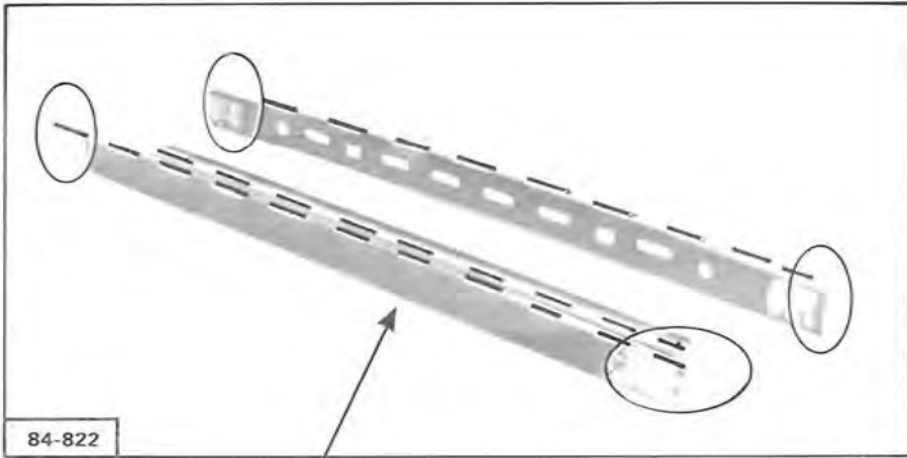

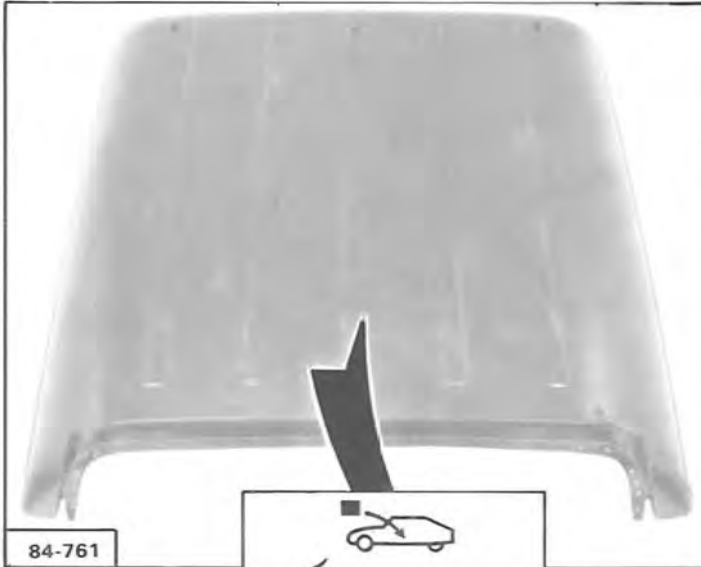

84-761

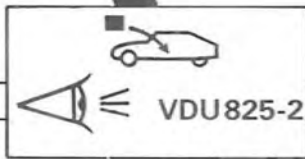

VDU825-2

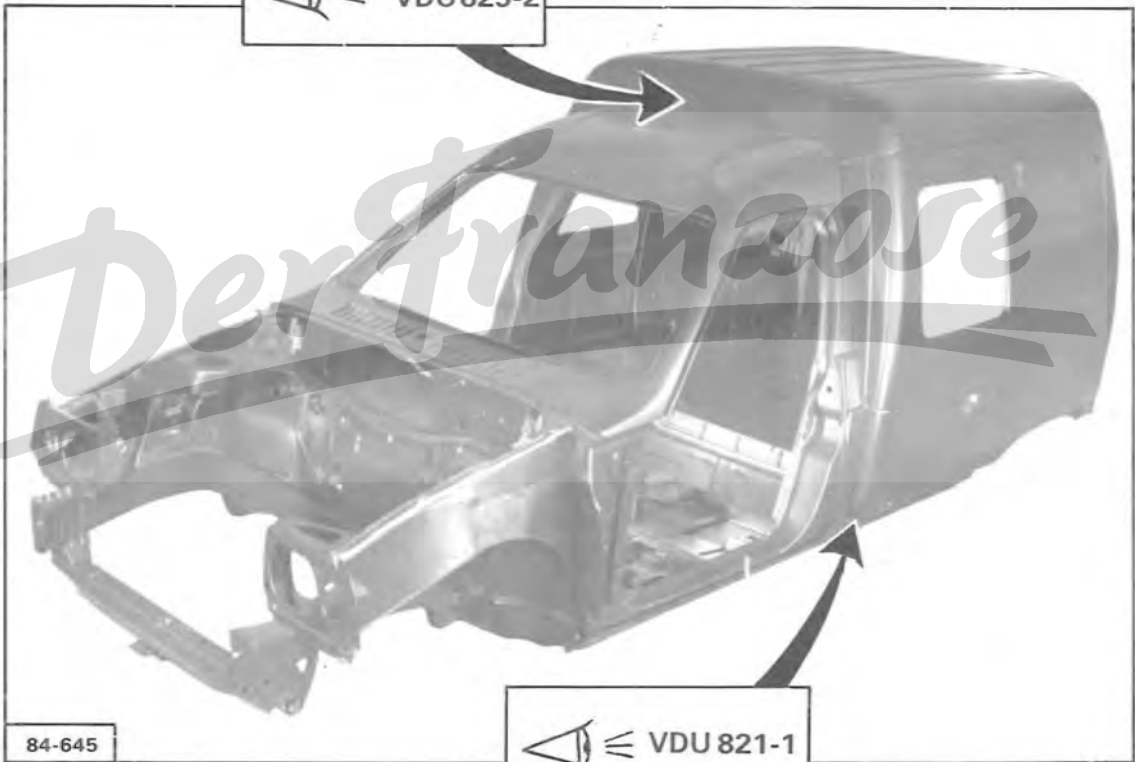

84-645



VDU 821-1

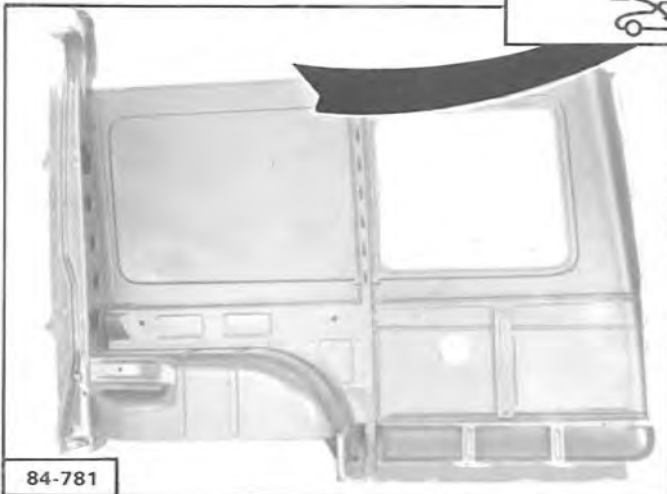

84-781

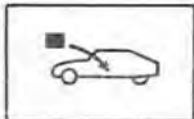

V 80-121



V 80-73

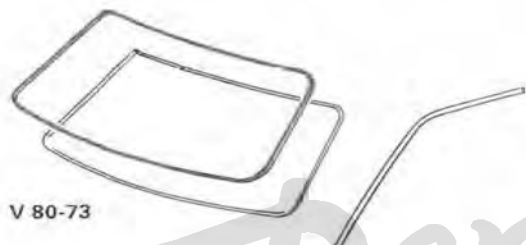

V 80-73



V 80-73

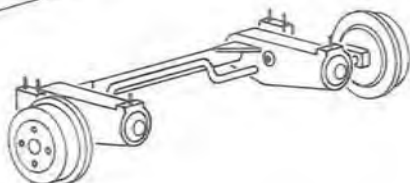
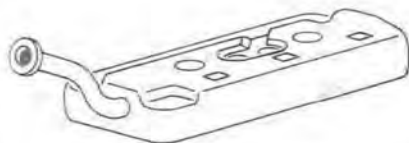
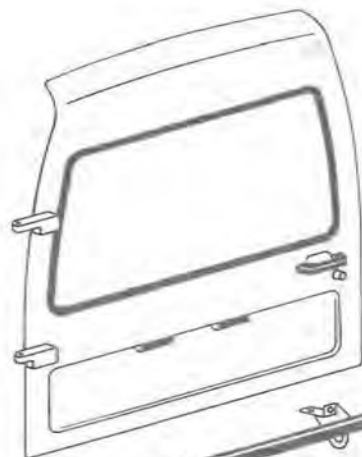
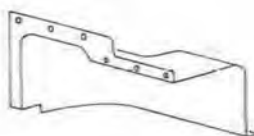
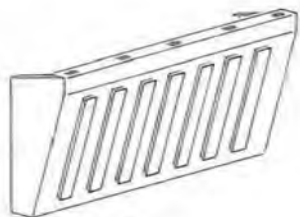

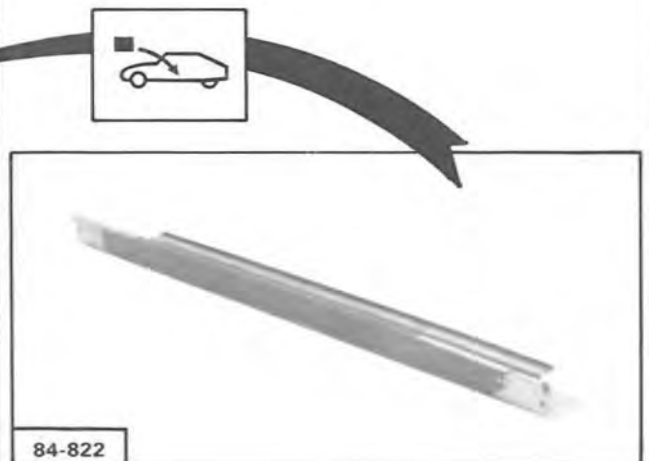
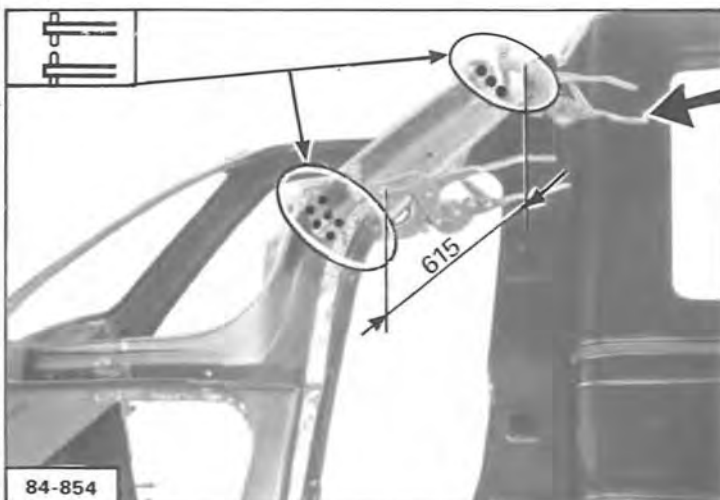
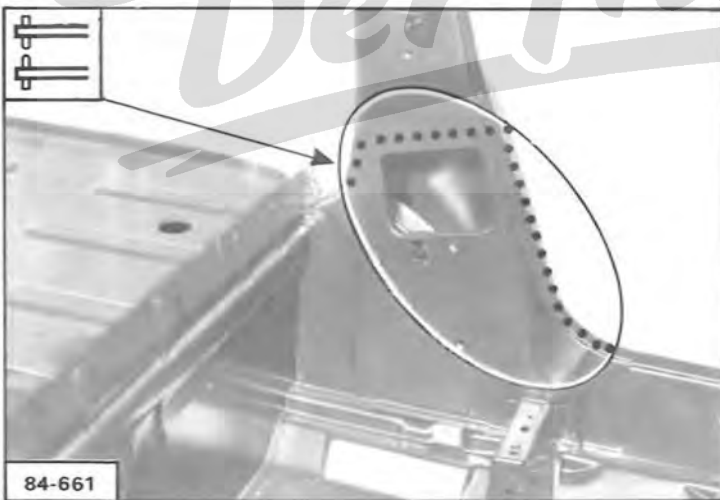
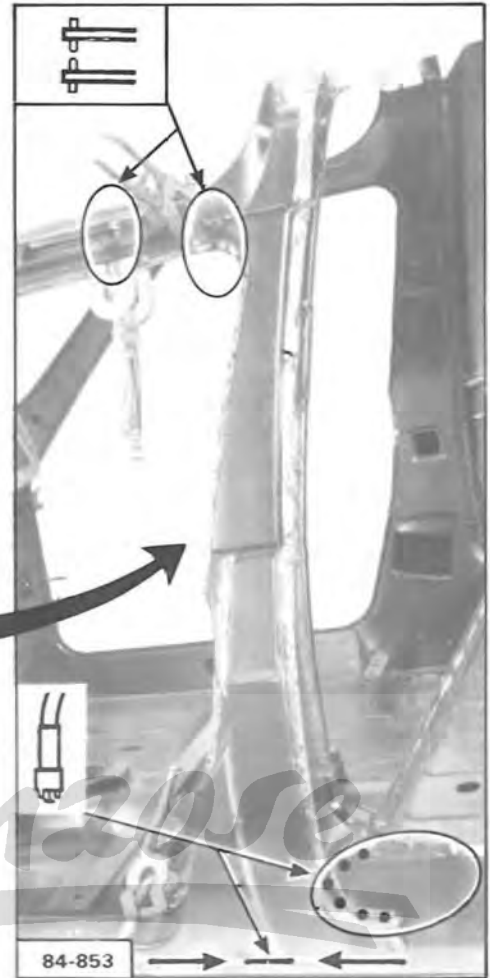

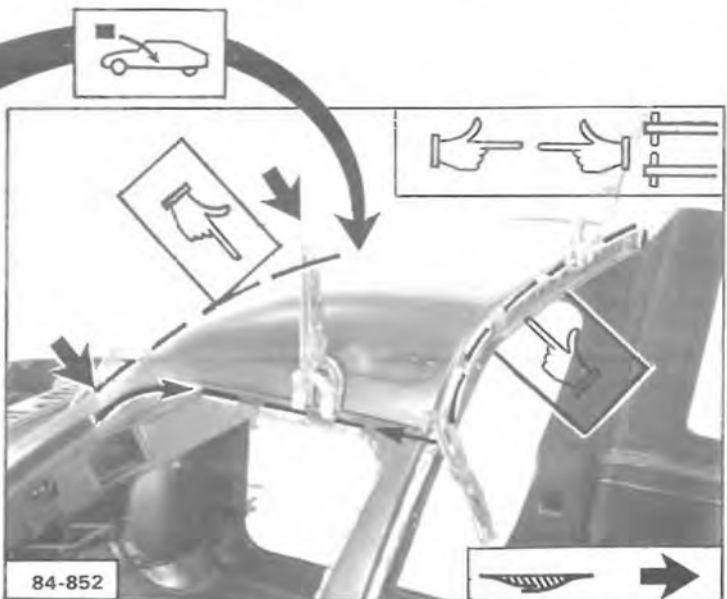
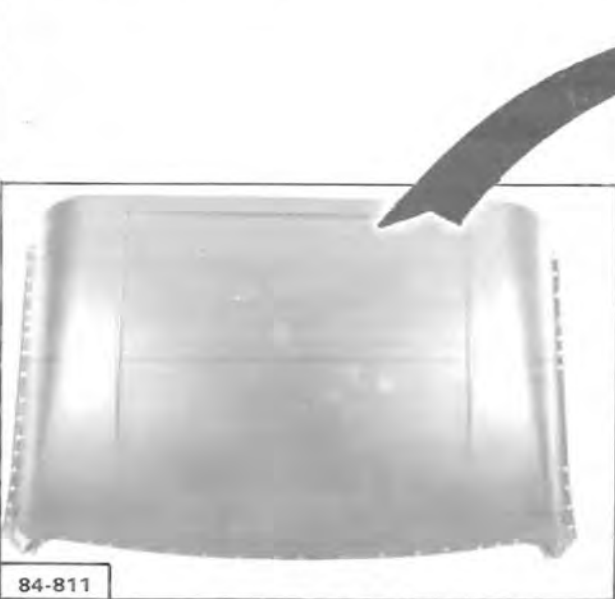
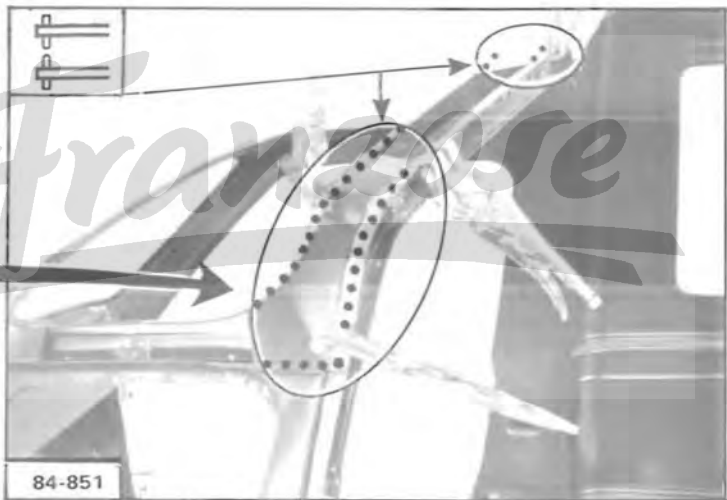
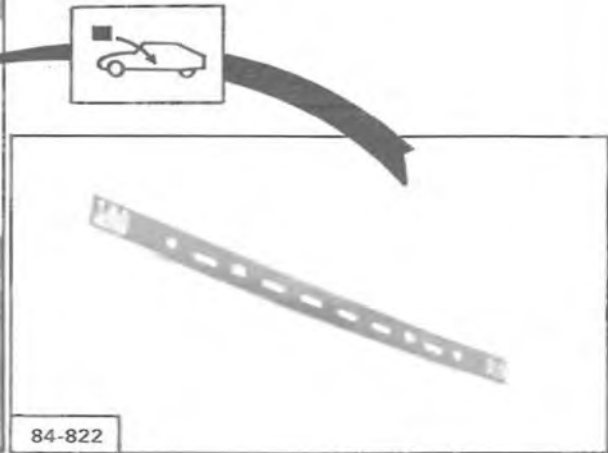
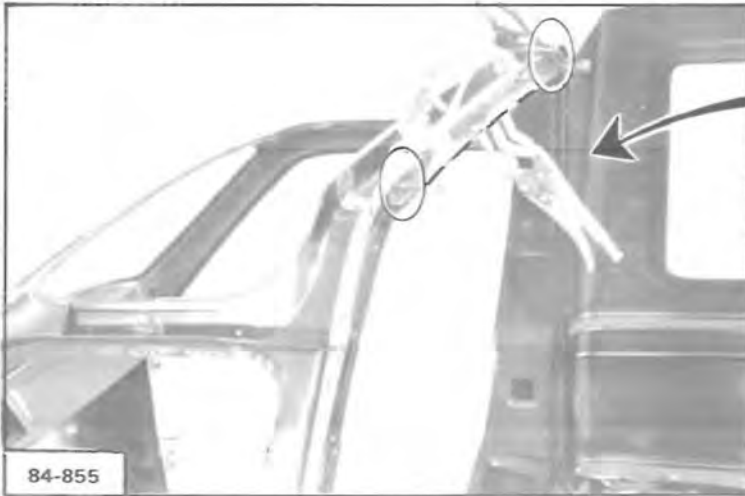

| Arbeitsvorgang Nr. | Bezeichnung |
|---|--|
| VD.Di 851-1 VD.Di 852-1 VD.Di 853-1 | Frontpartie: Erneuern eines vorderen Kotflügels Erneuern der Motorhaube Erneuern der vorderen Stoßstange |
| VD.Di 853-4 | Hintere Stoßstange: Erneuern der hinteren Stoßstange |
| VD.Di 856-1 | Armaturenbrett: Erneuern des Armaturenbretts |
| VD.Di 961-1 VD.Di 961-4 | Fensterscheiben: Erneuern der Windschutzscheibe Erneuern der Heckscheibe |
| MR 630-84/44 | Werkzeug: Plan zur Herstellung des in diesem Kapitel verwendeten MR-Werkzeug: Haken zum Öffnen der Motorhaube |

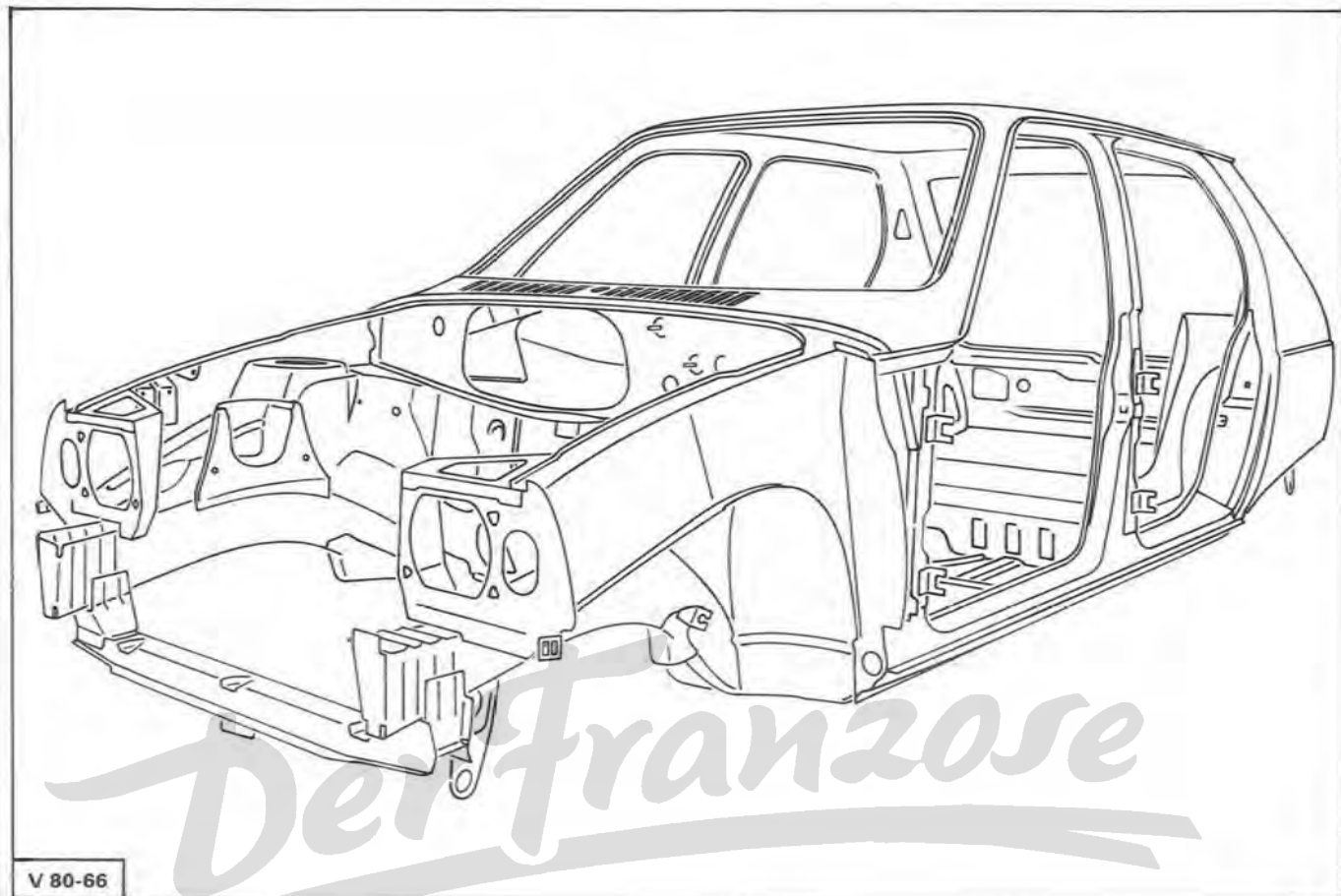

V 80-66



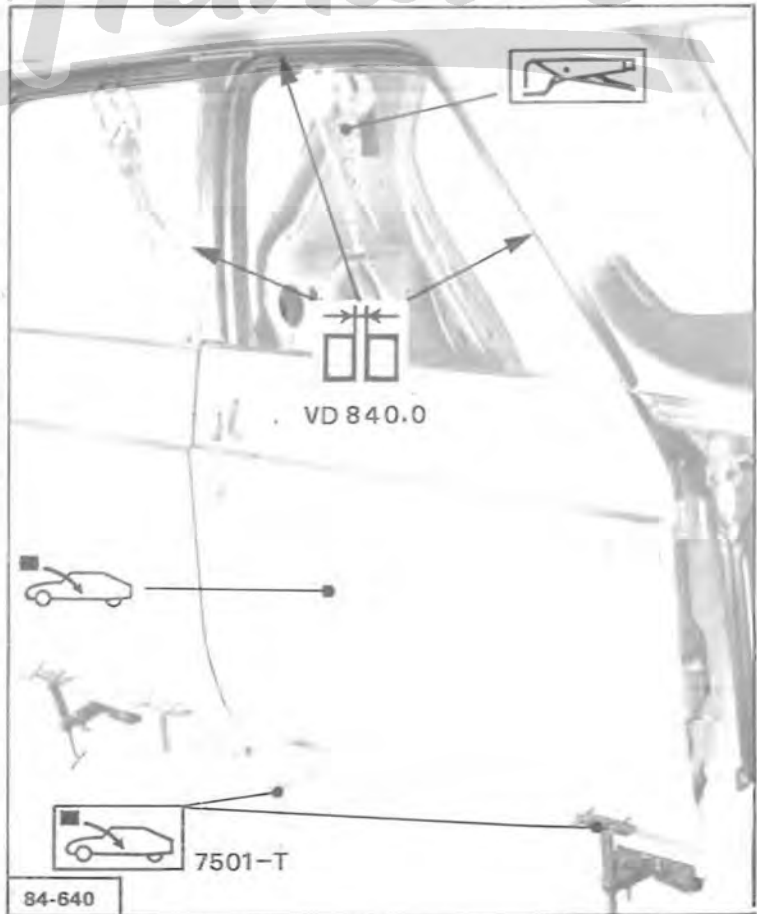
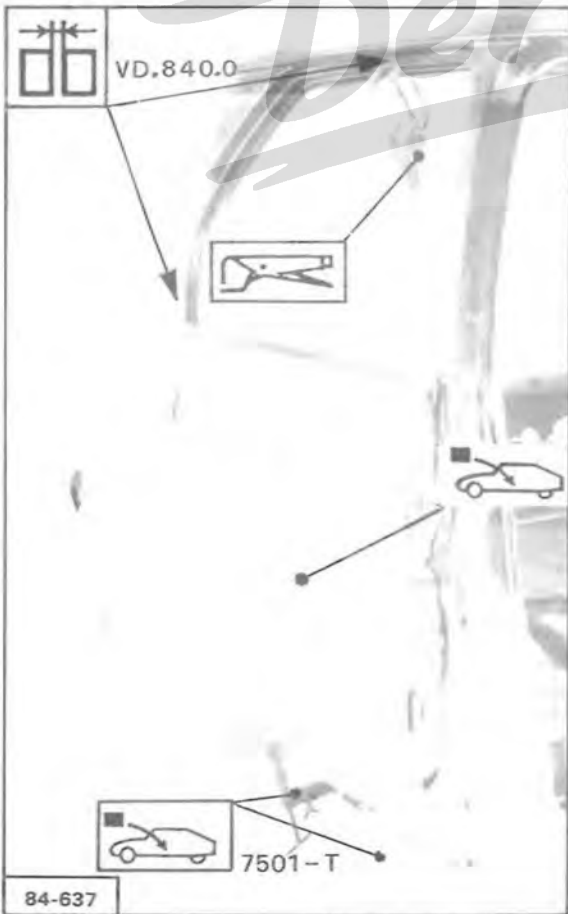
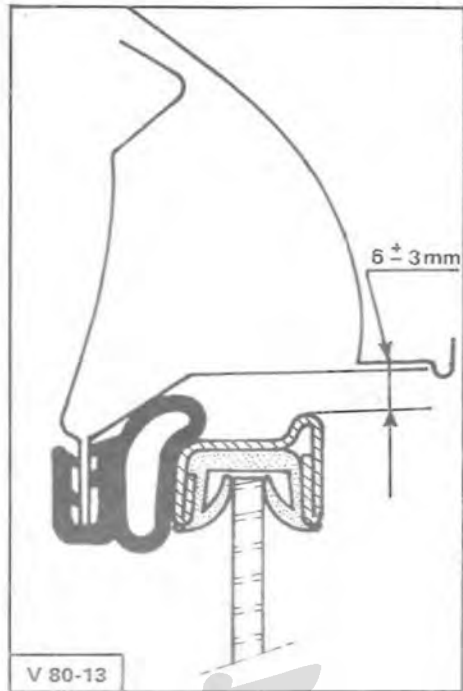

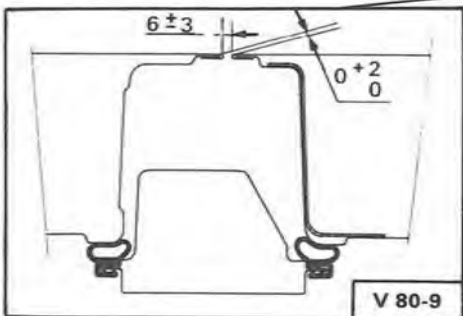
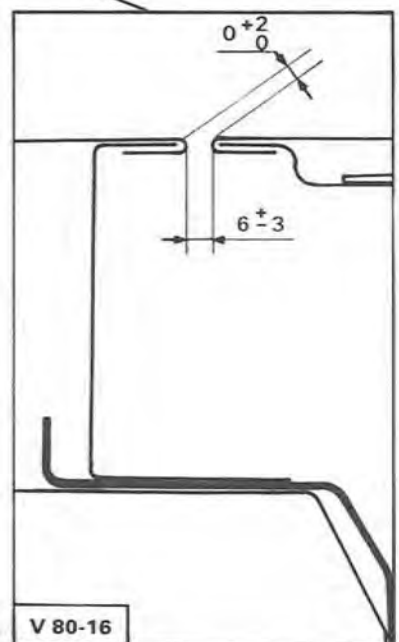
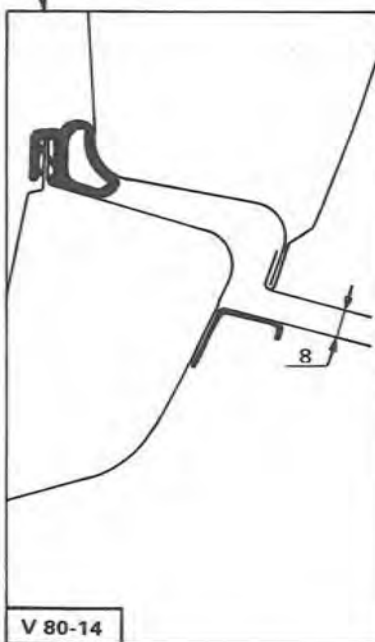
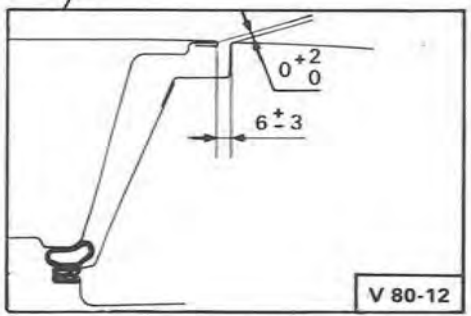
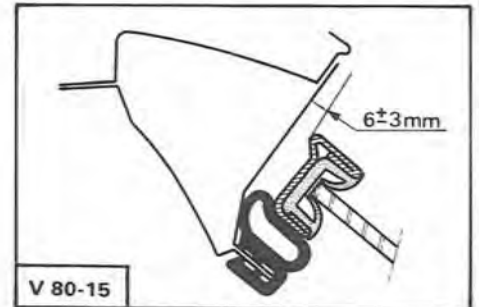
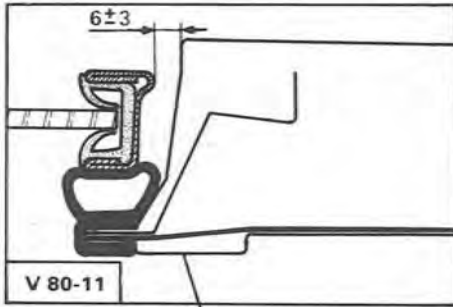
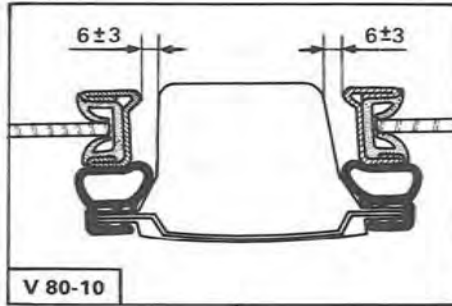



84-636

Der Franzose



84-640

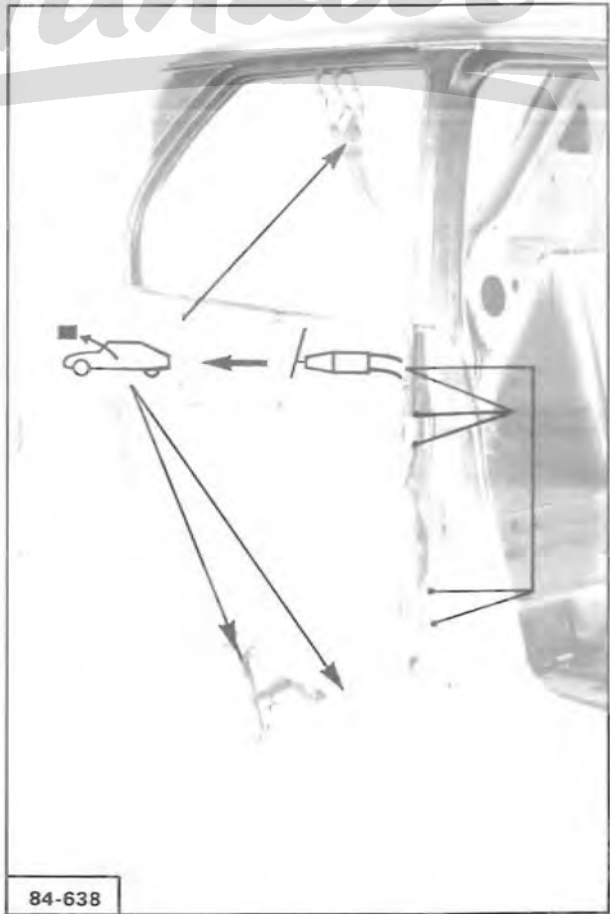

84-638

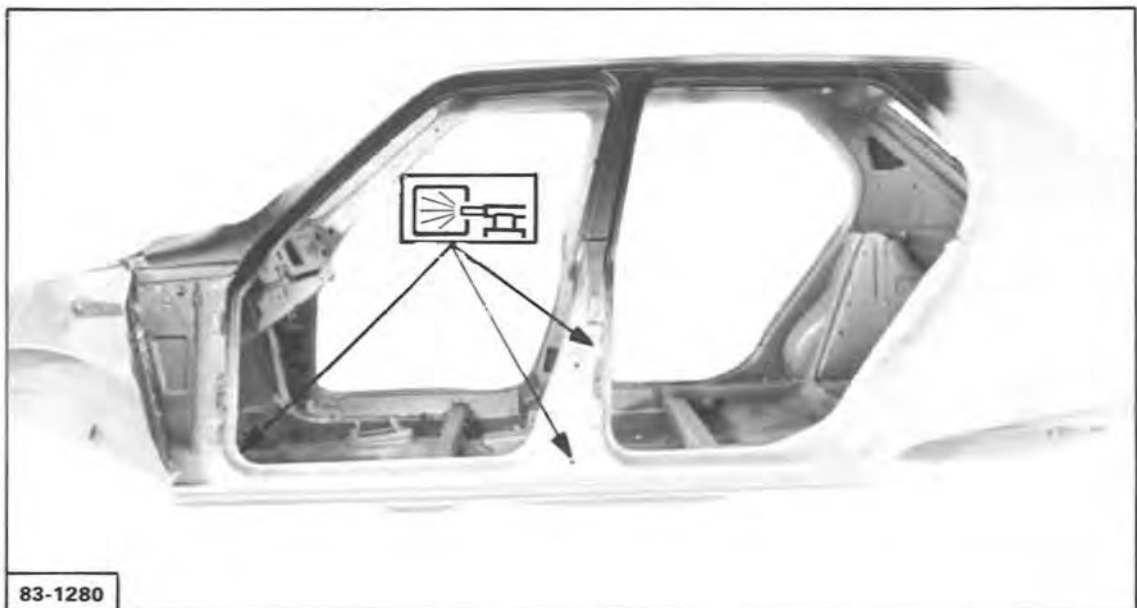
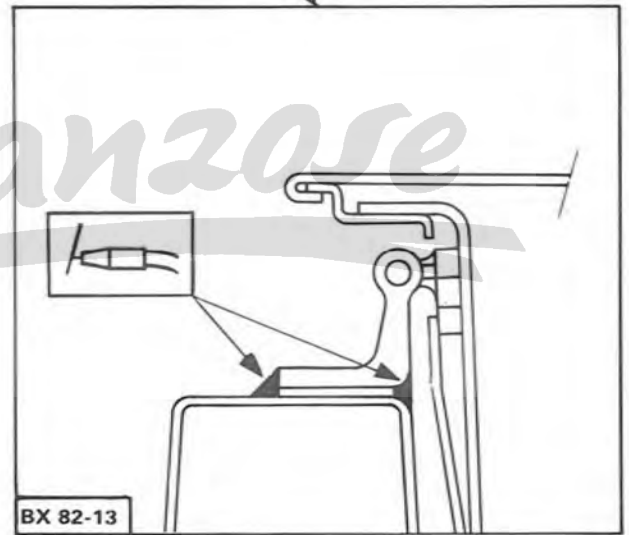
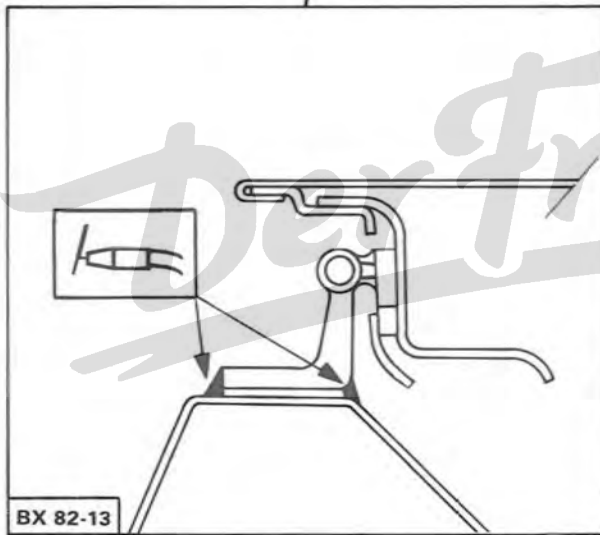
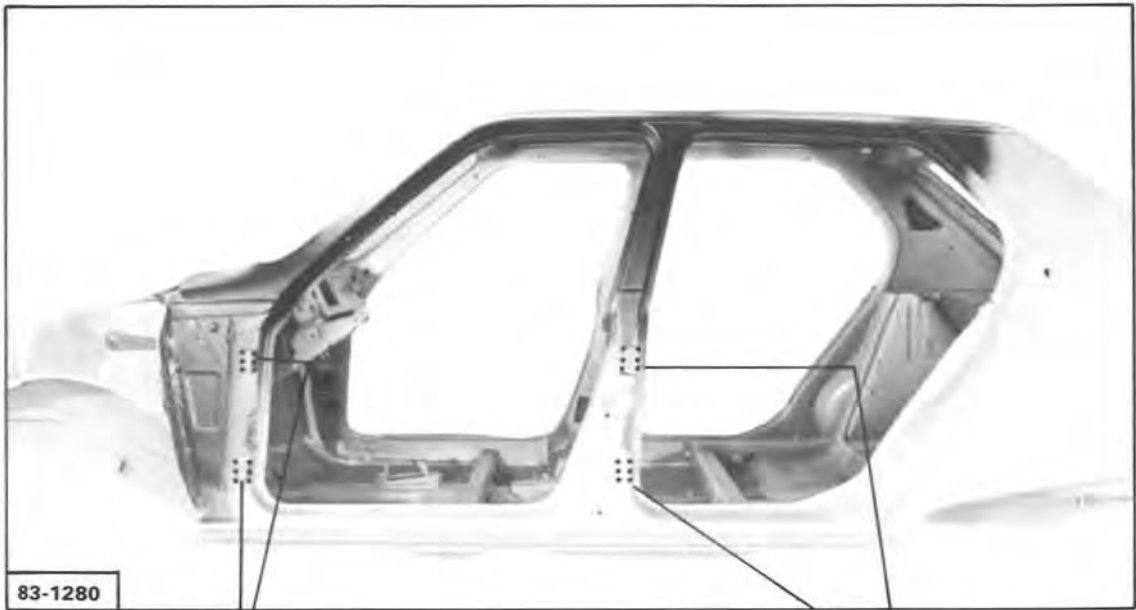

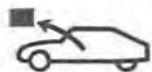

V. 80-73

Der Franzose

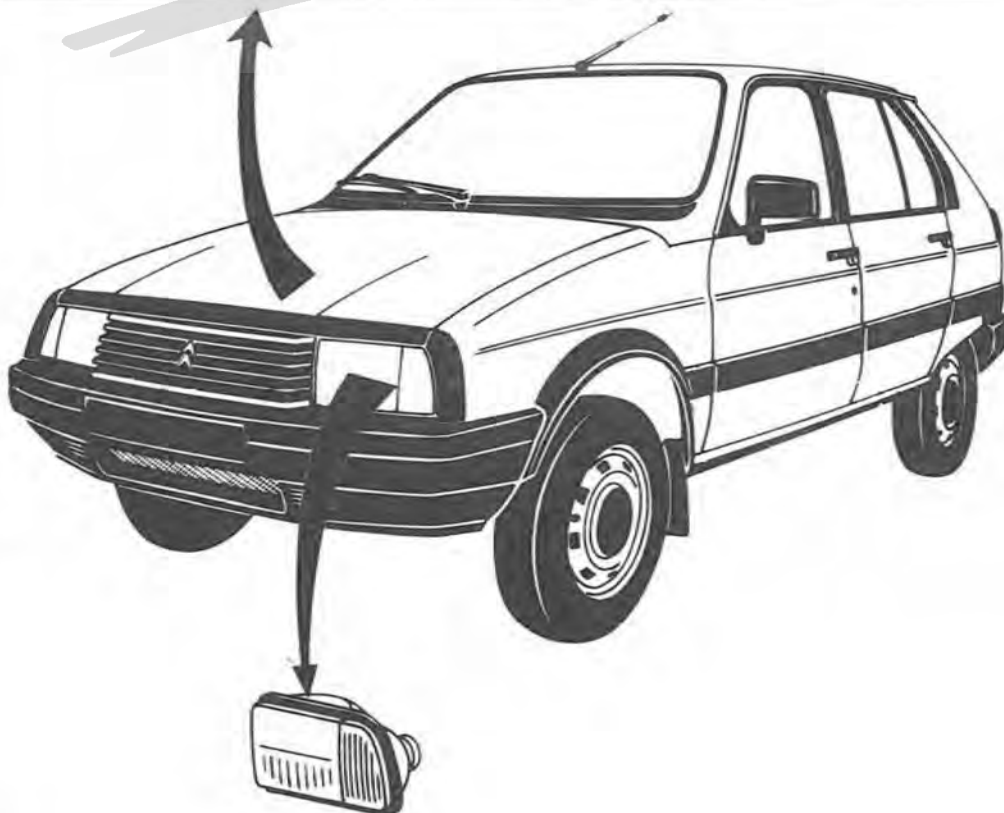

V. 80-73

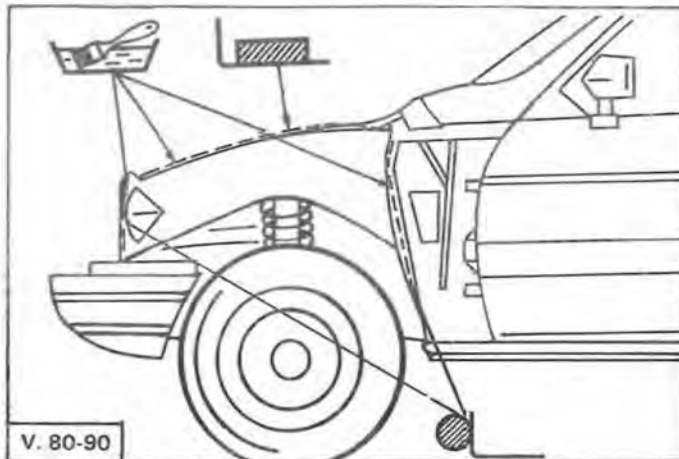
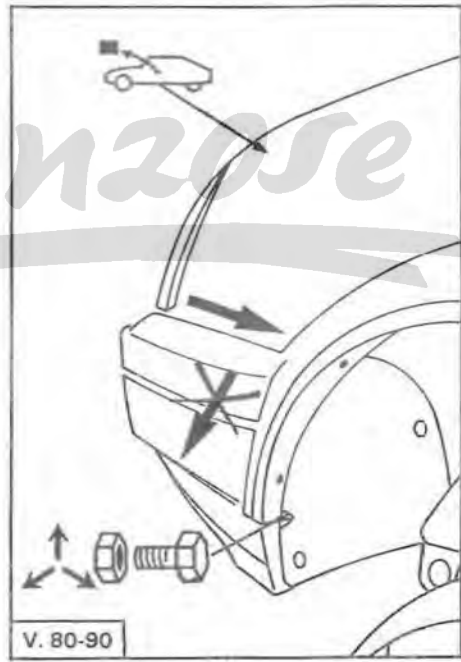
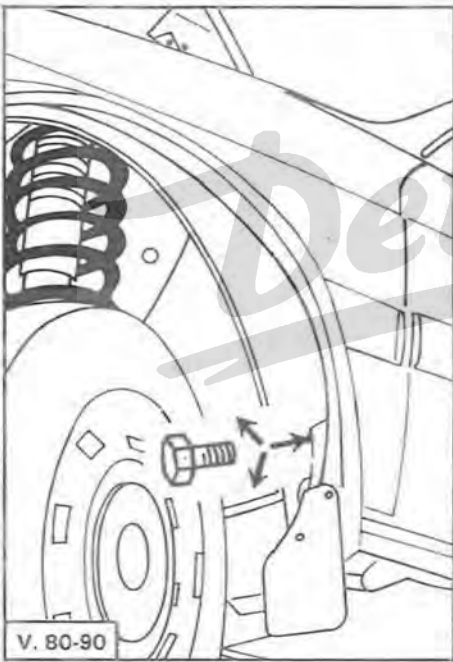
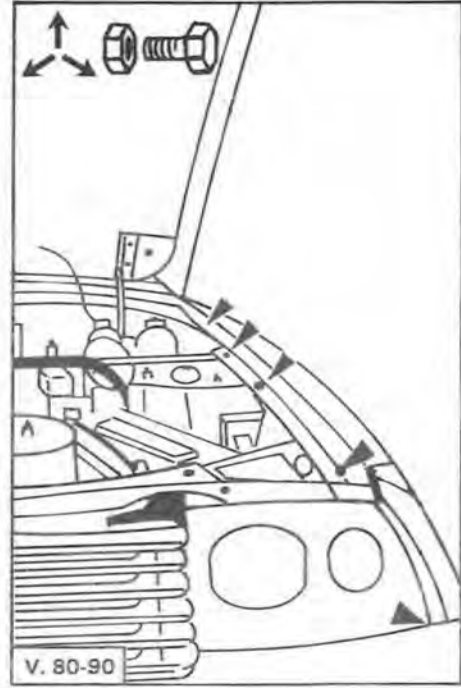
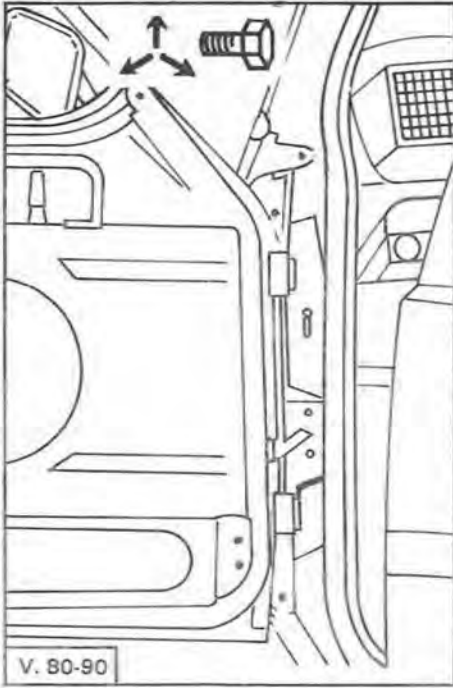
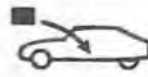

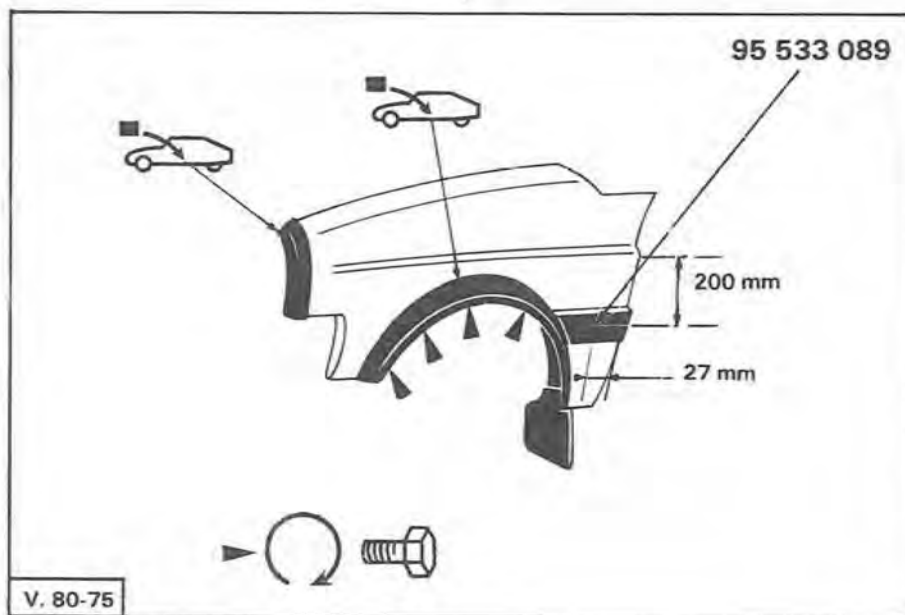
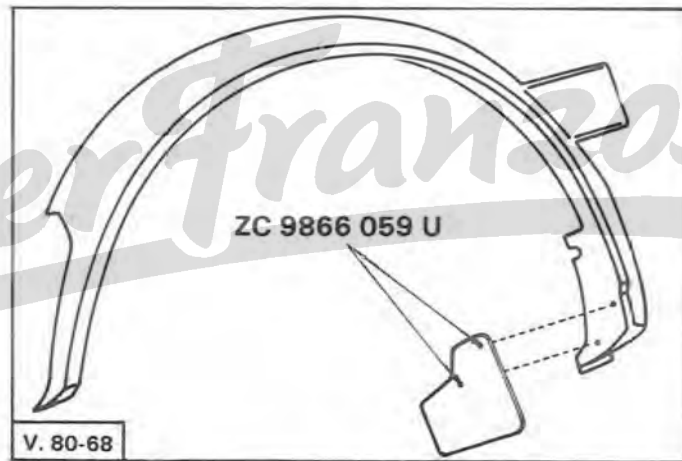
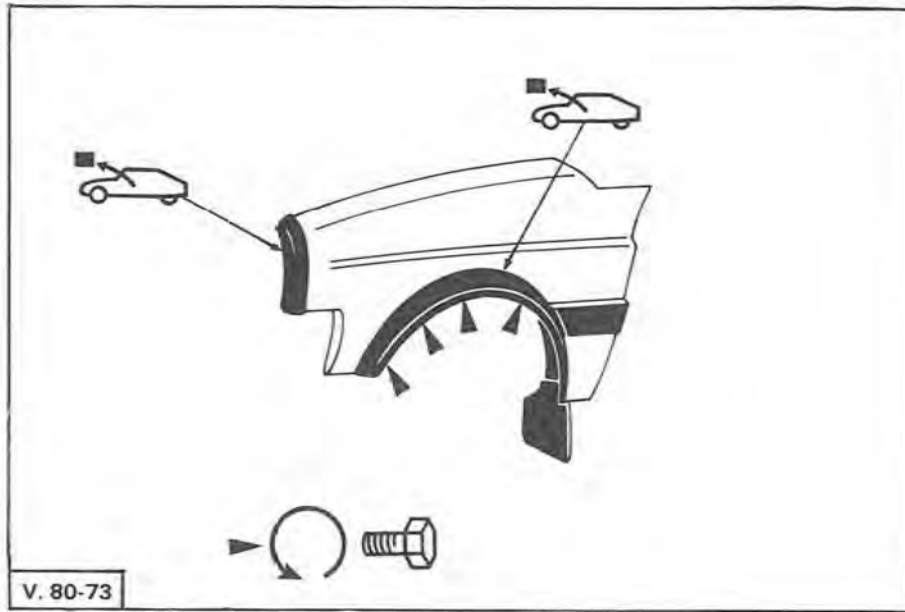
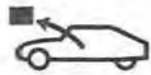

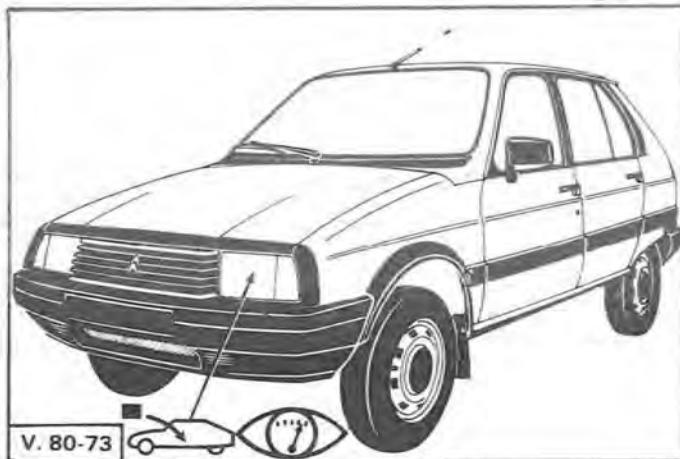
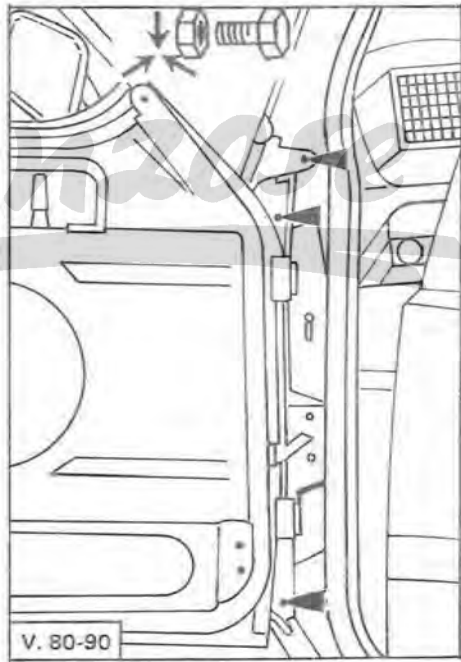
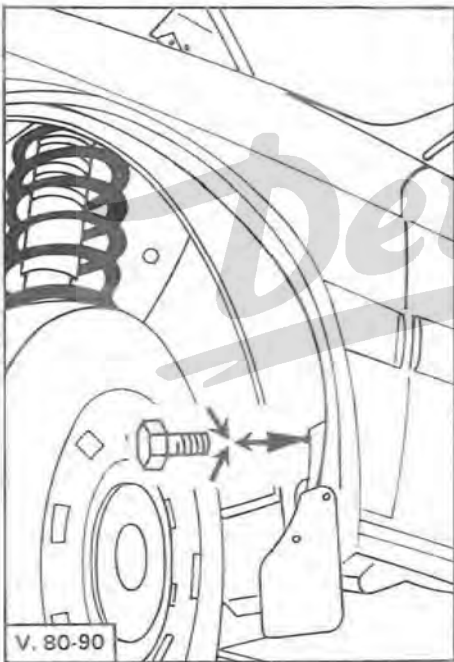
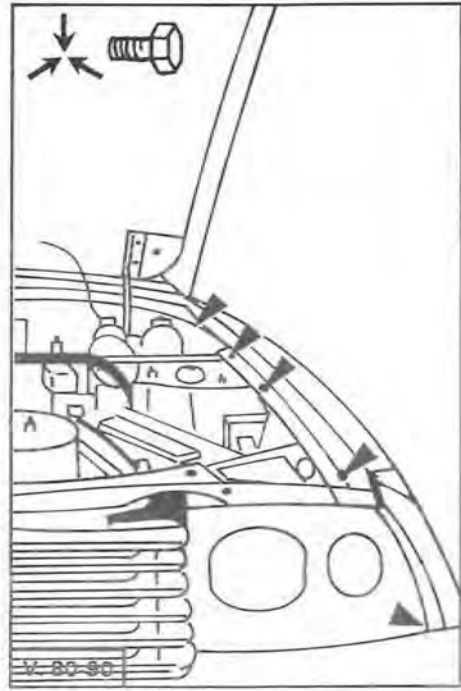
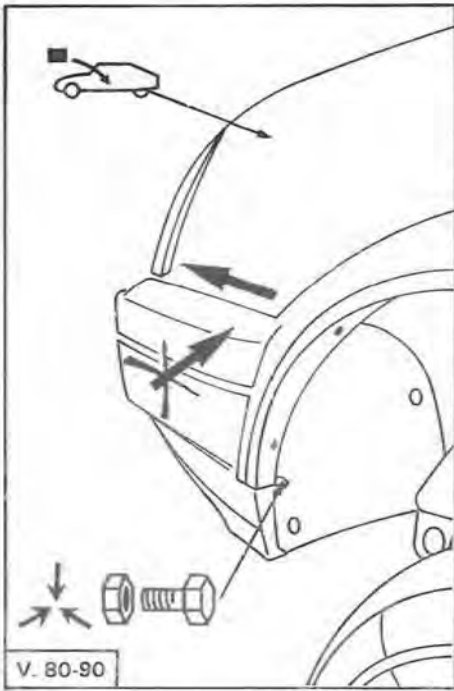
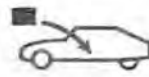

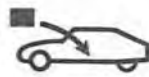

V. 80-73

Derfranchise

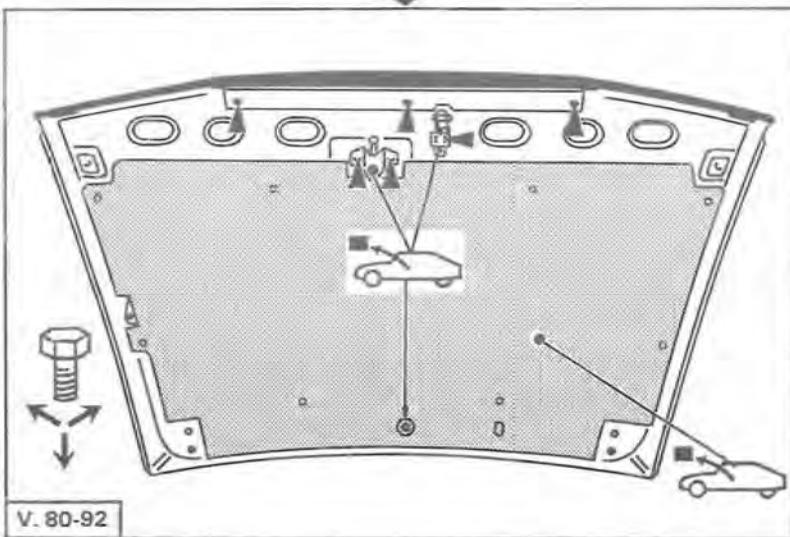
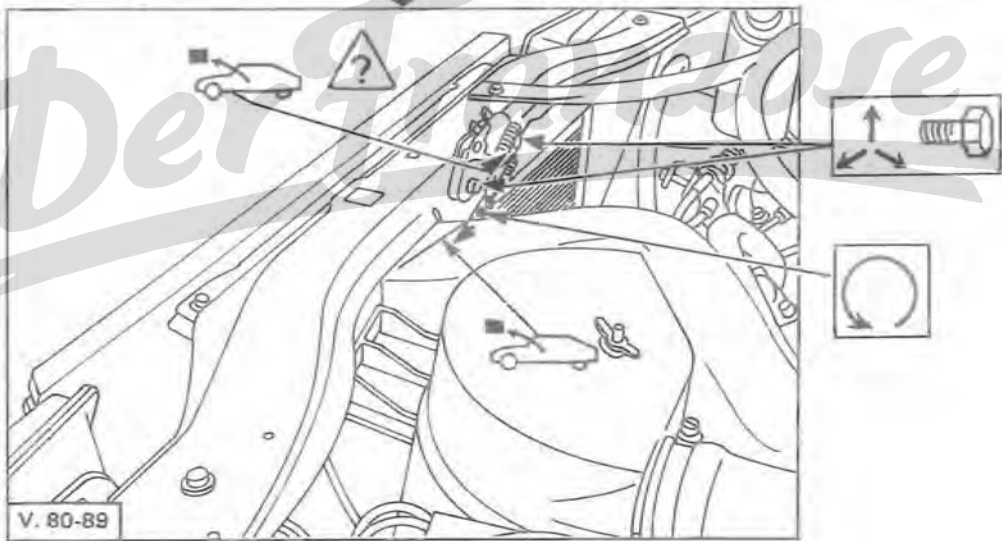
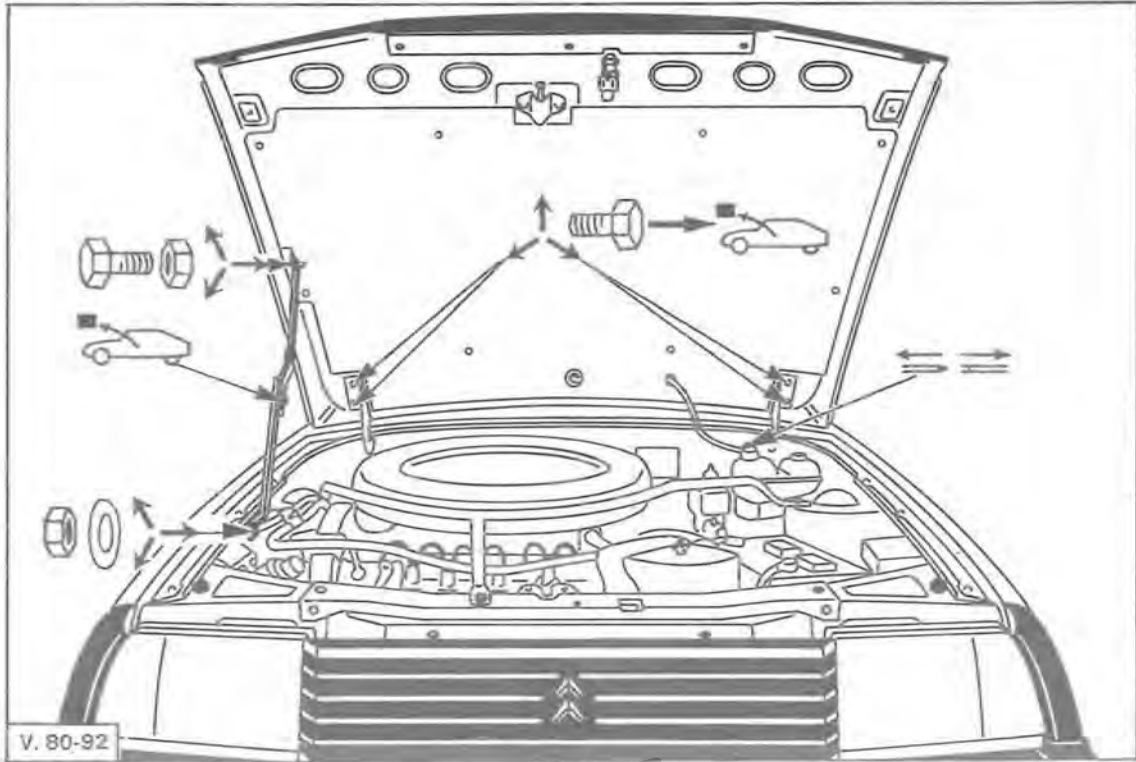
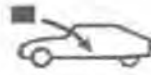
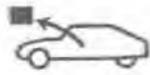

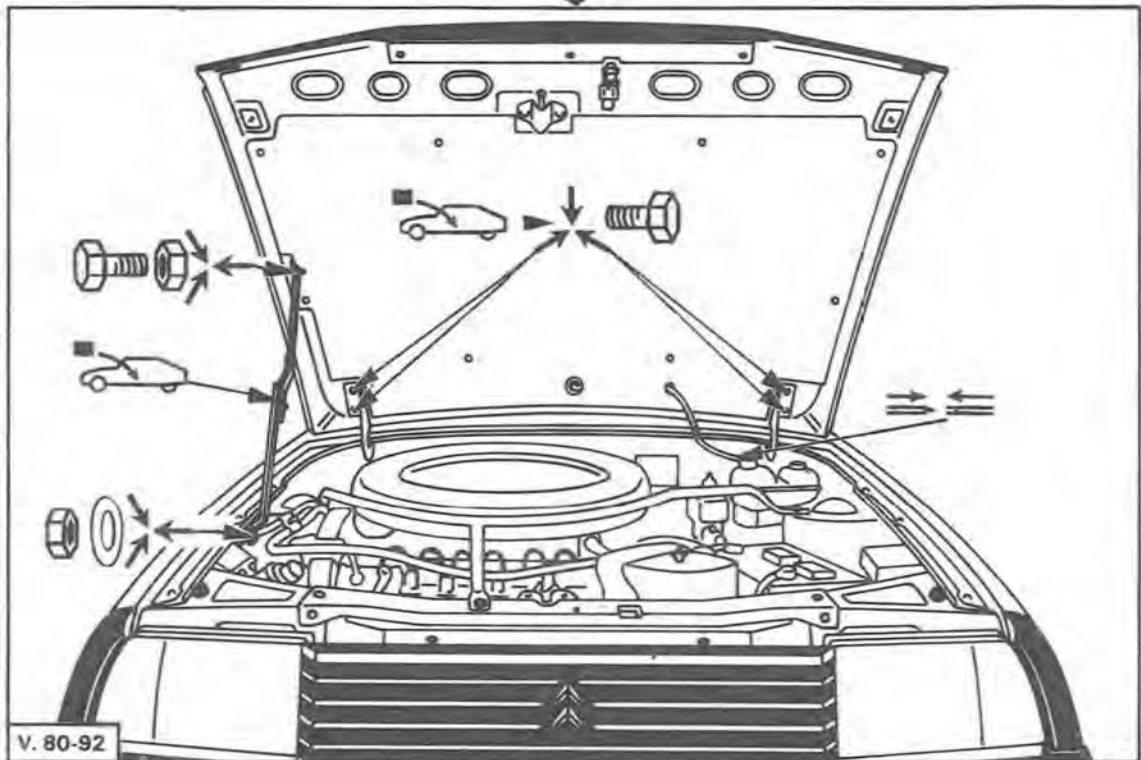
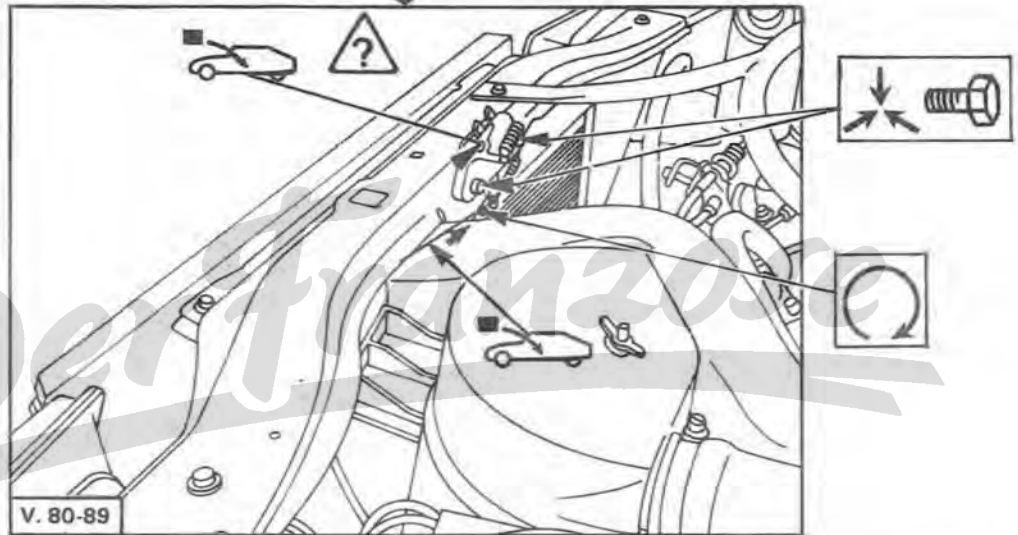
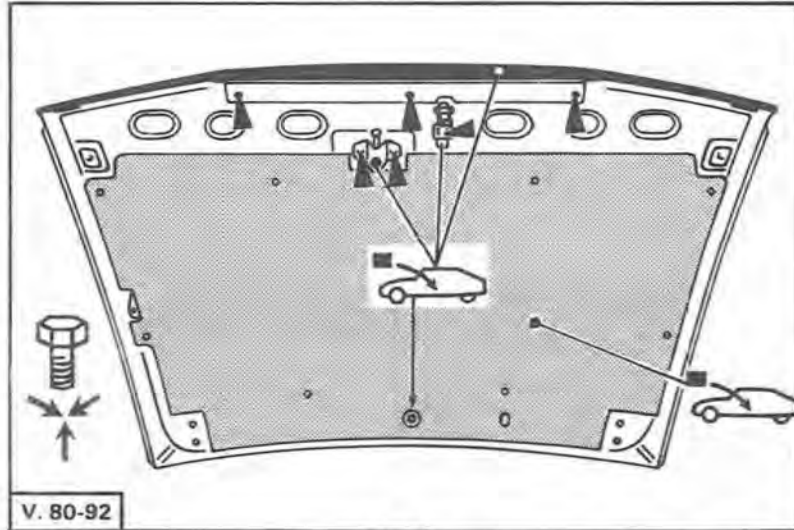

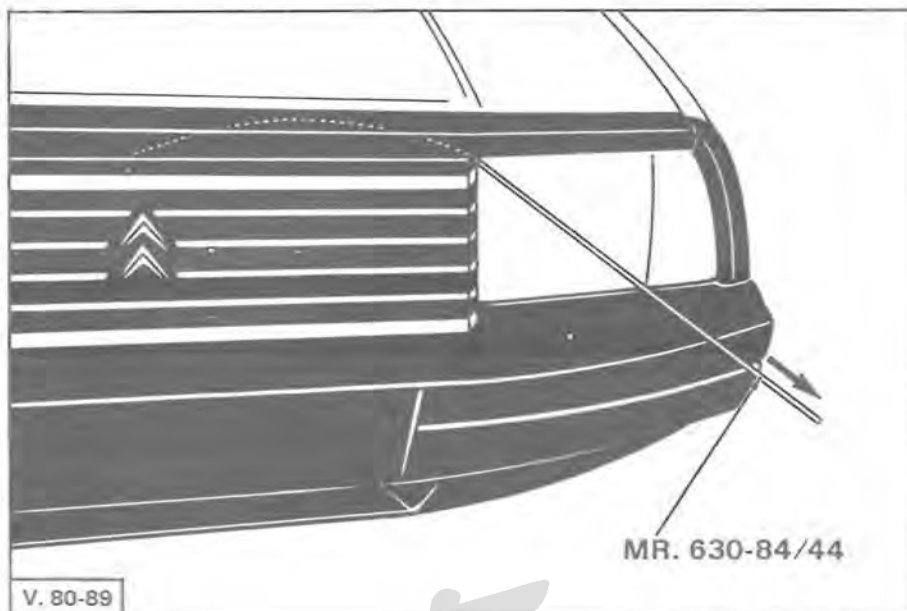
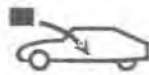
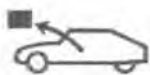

Der Franzose

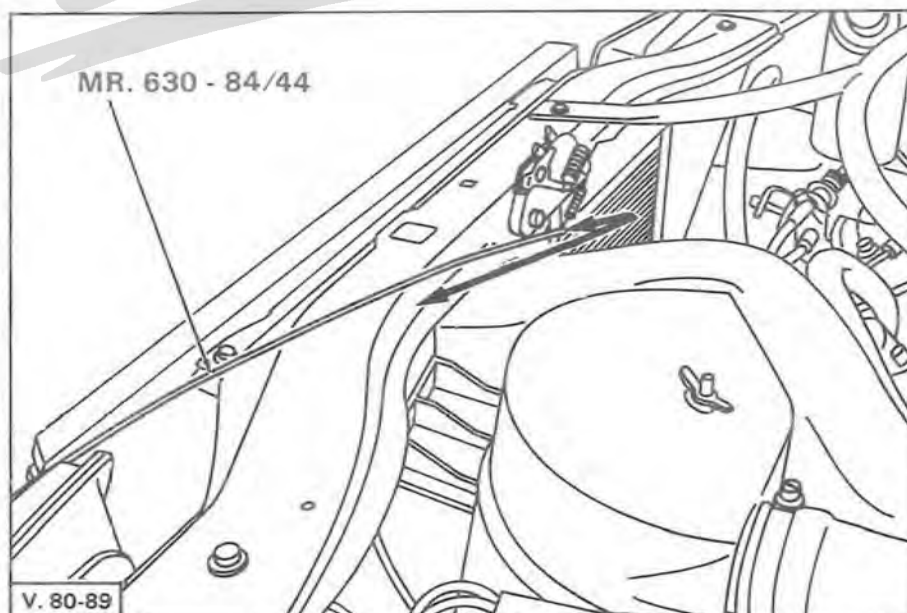

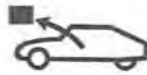

V. 80-73

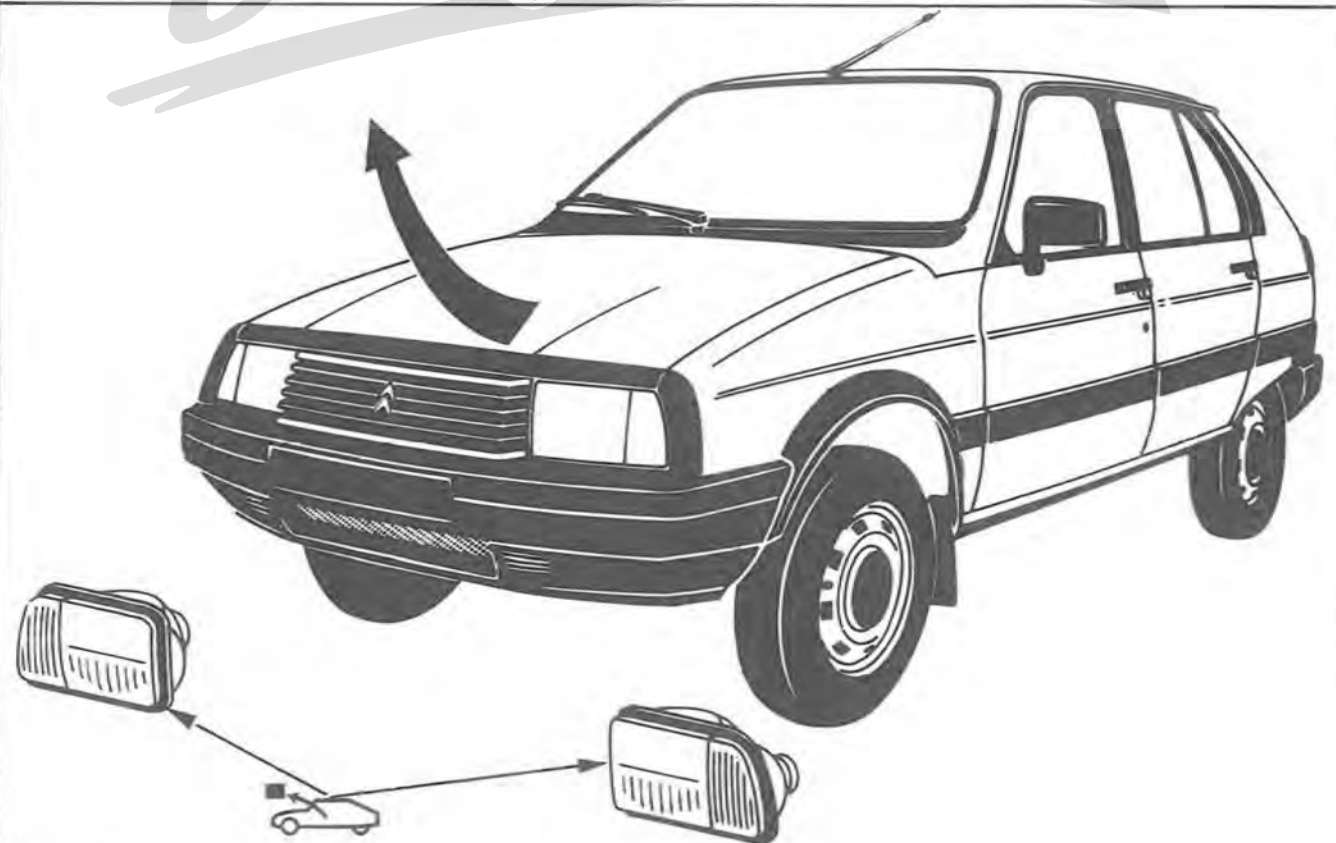

V. 80-73

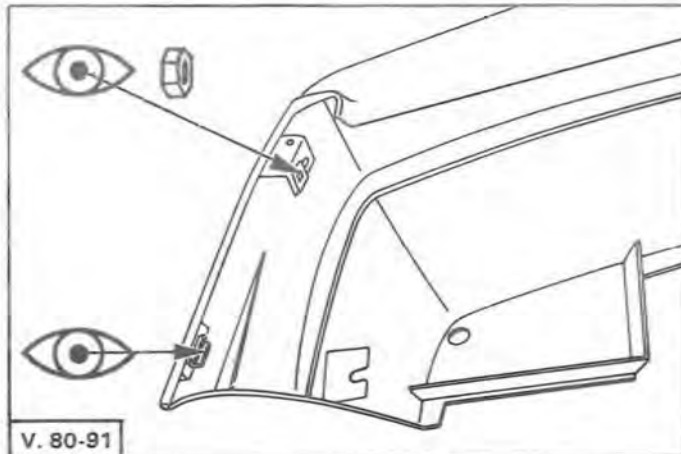
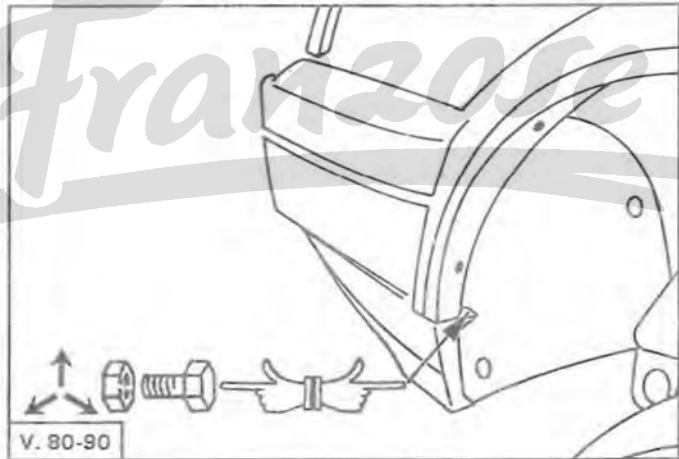
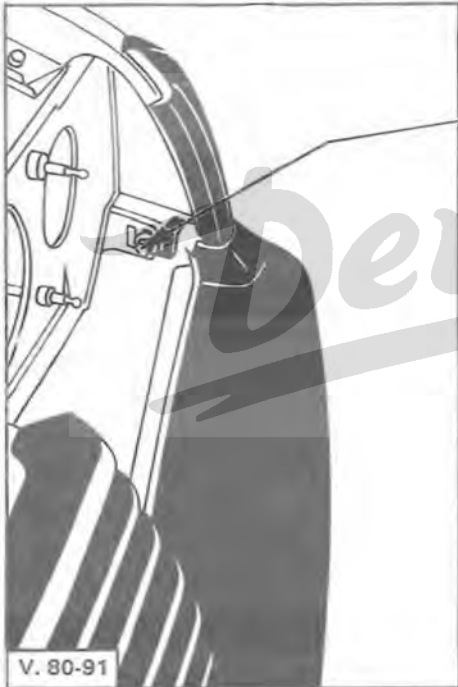
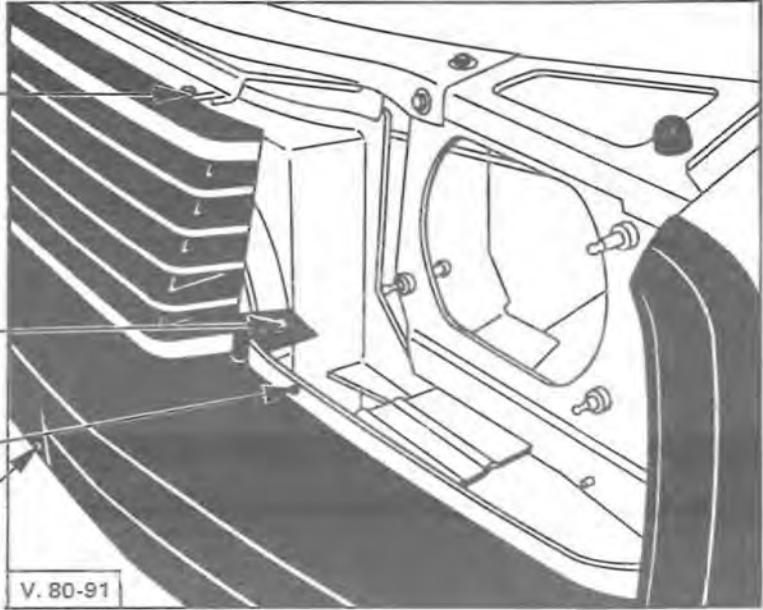
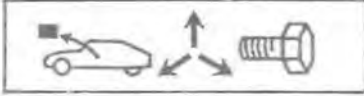
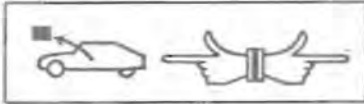
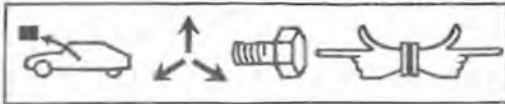
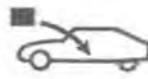
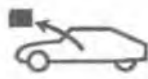

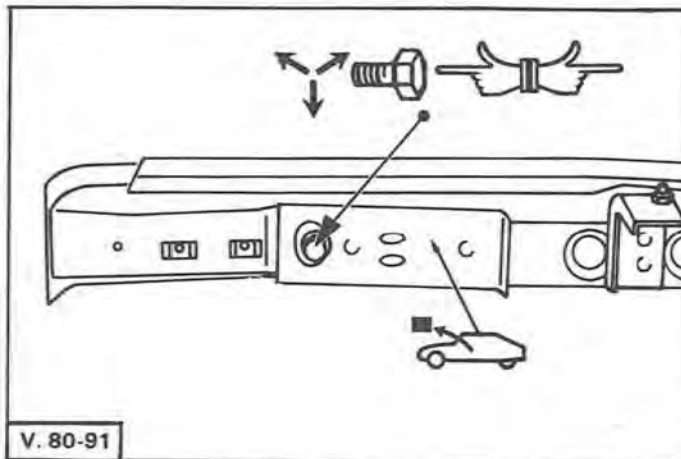
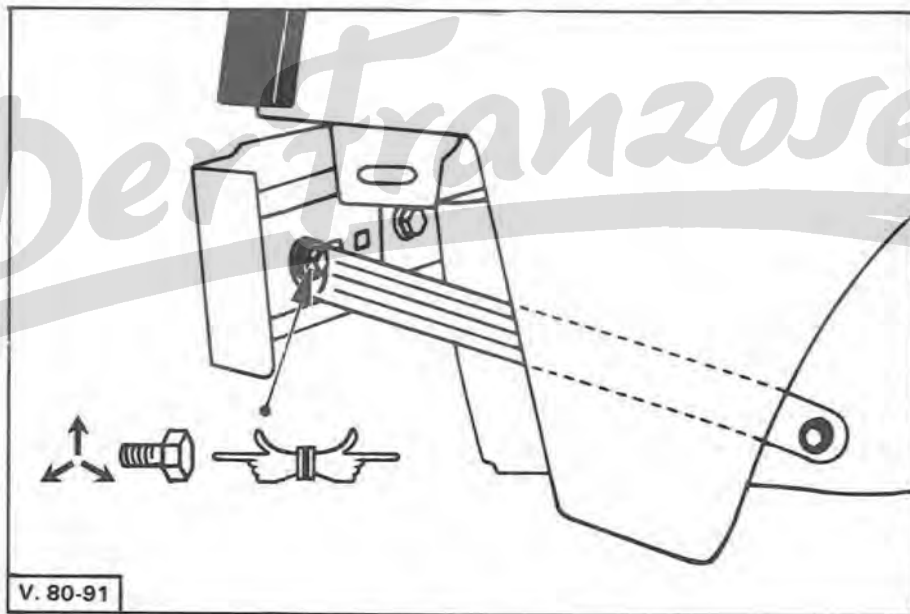
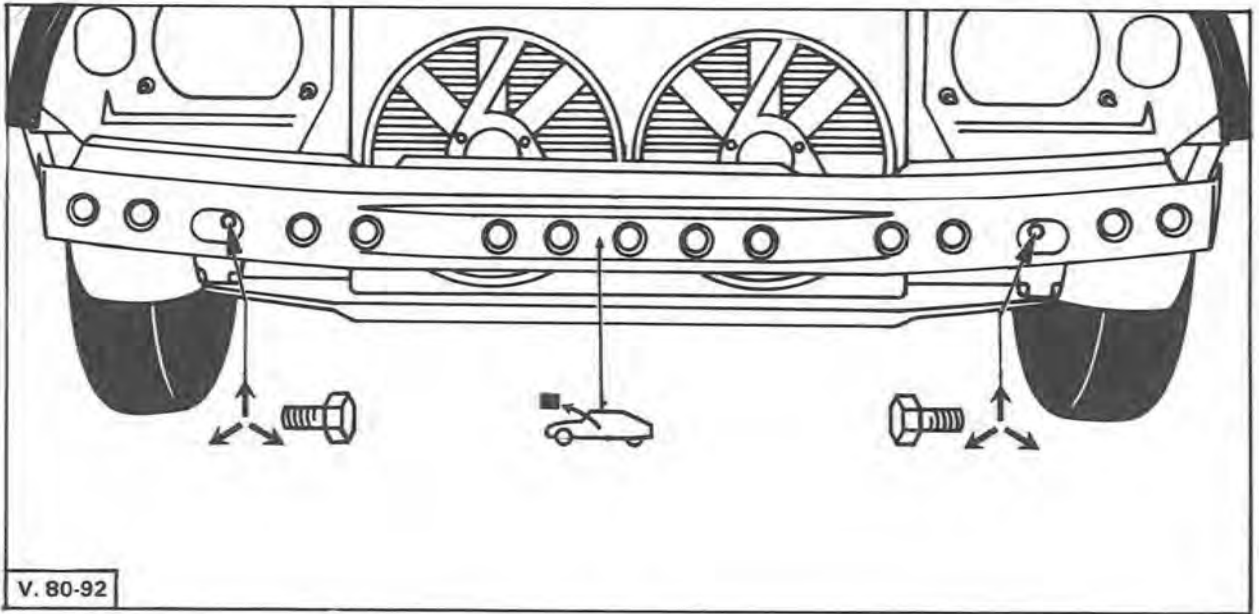
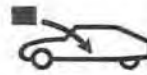
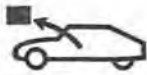

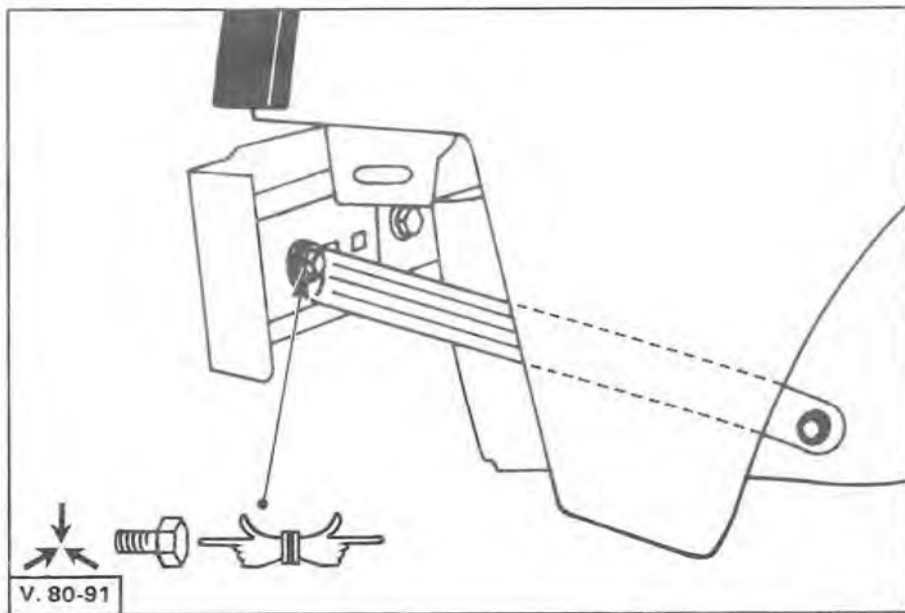
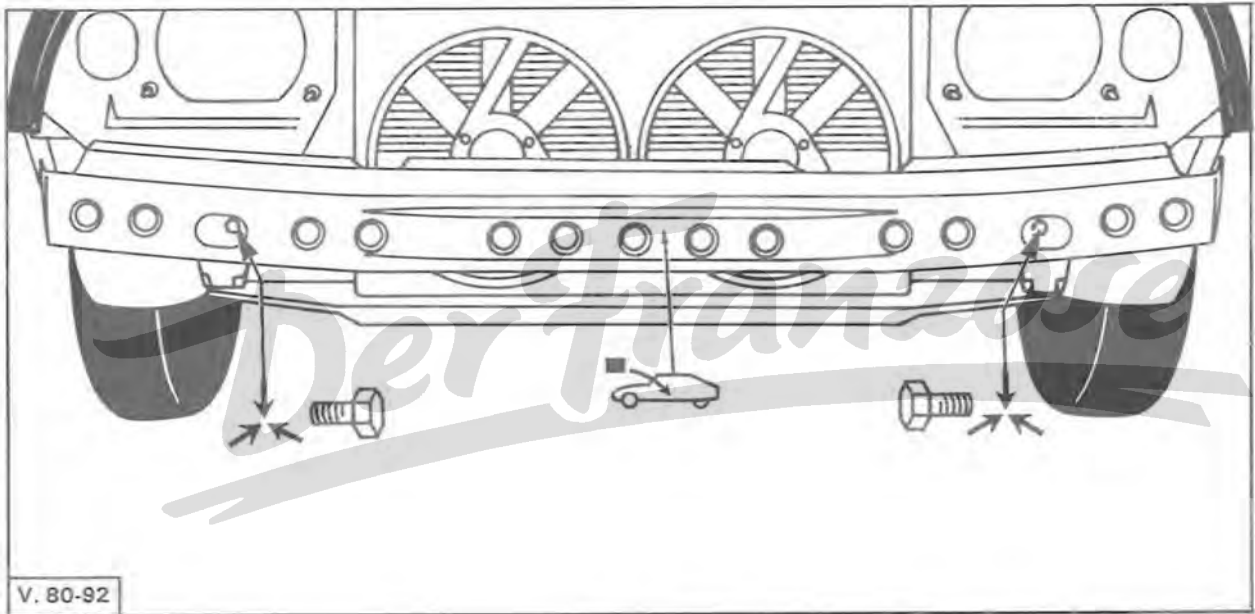
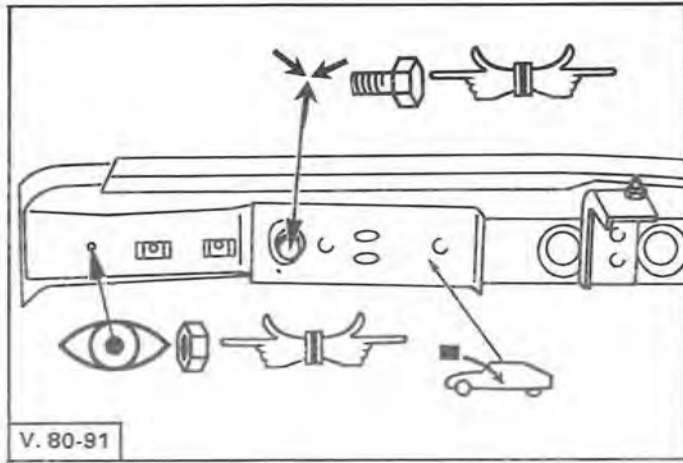
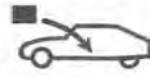

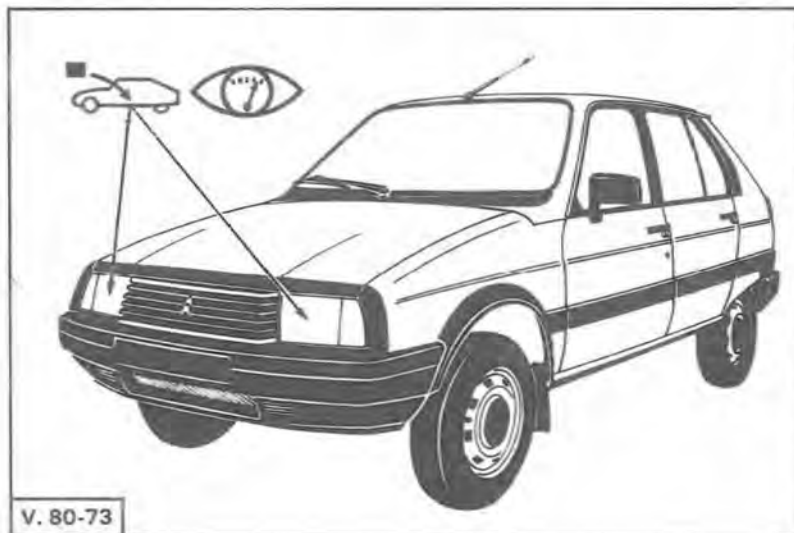
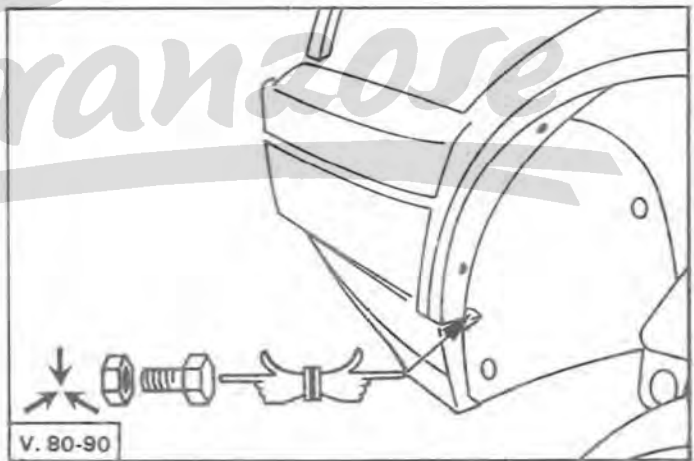
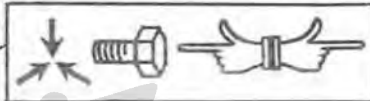
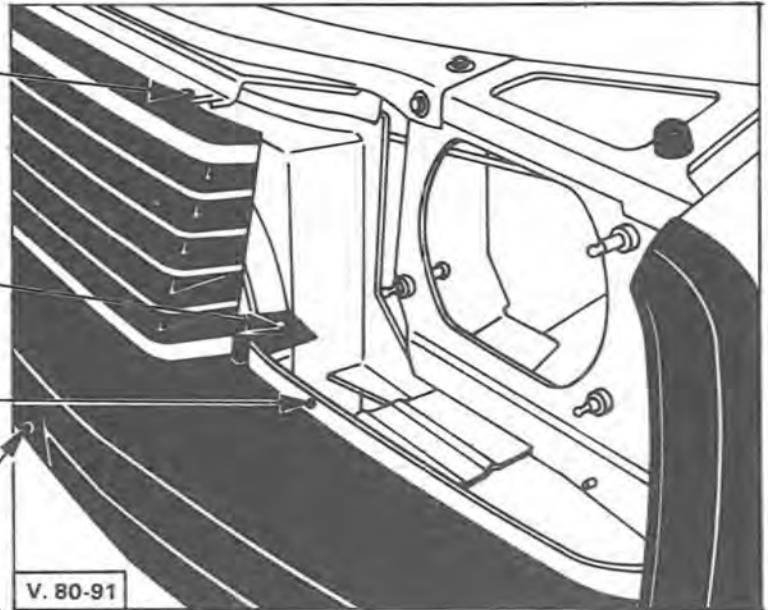
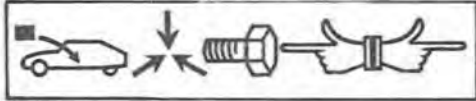
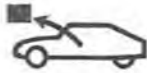



V. 80-75



V. 80-75

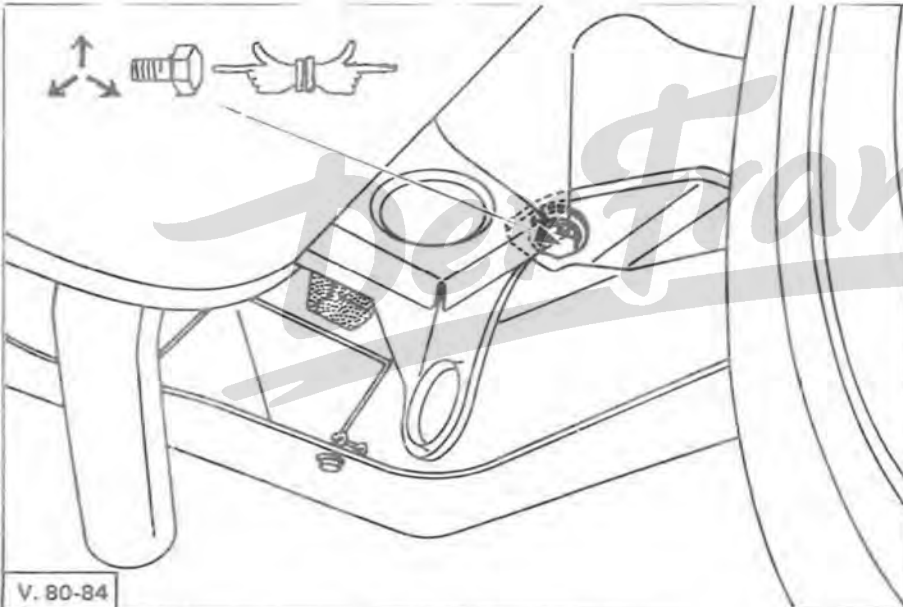

V. 80-84

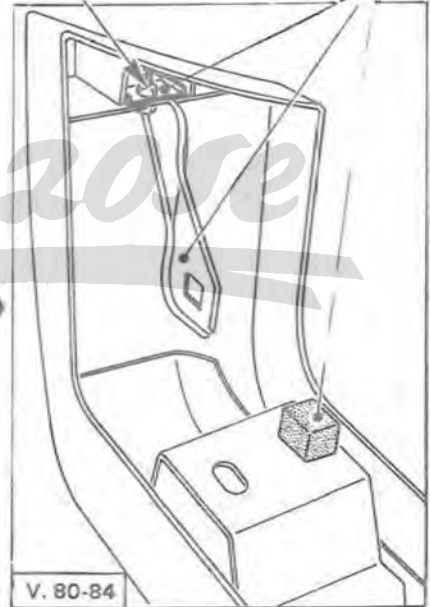

V. 80-84

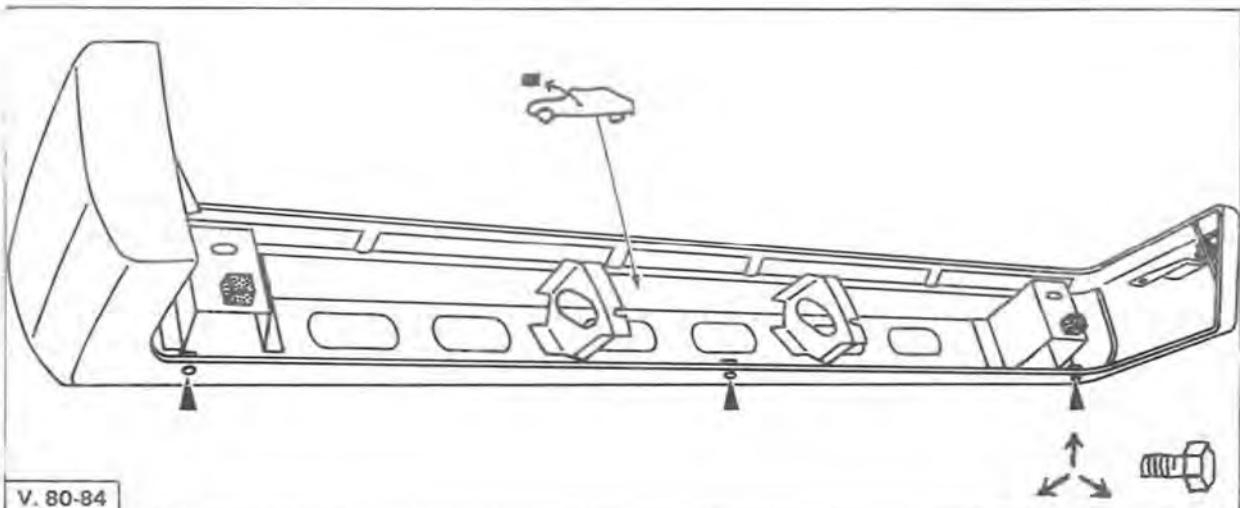

V. 80-84



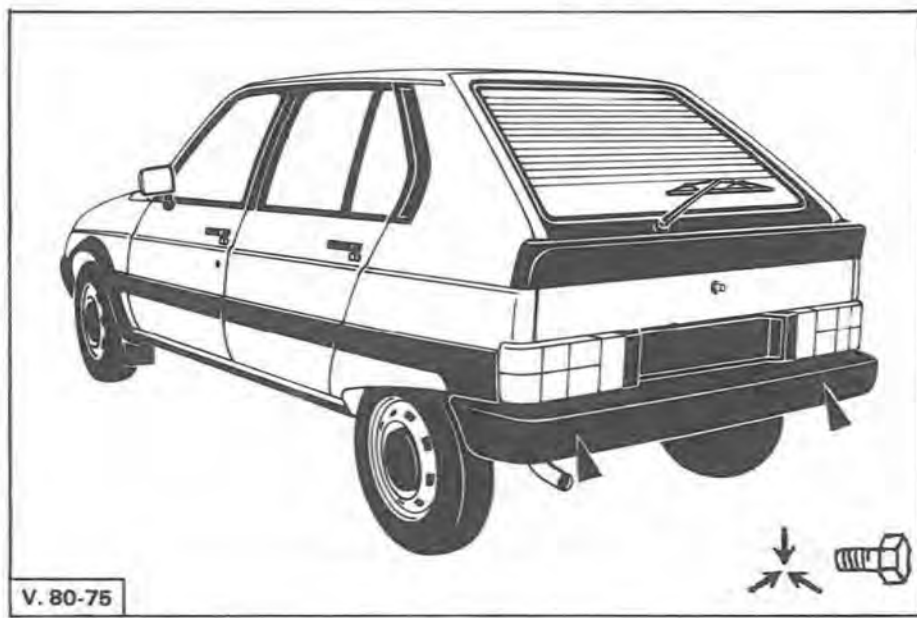
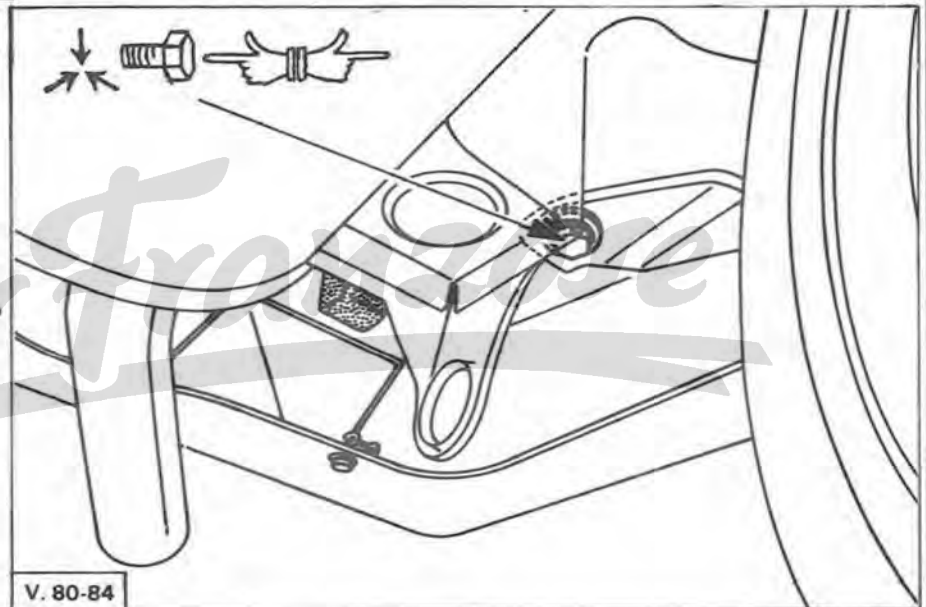
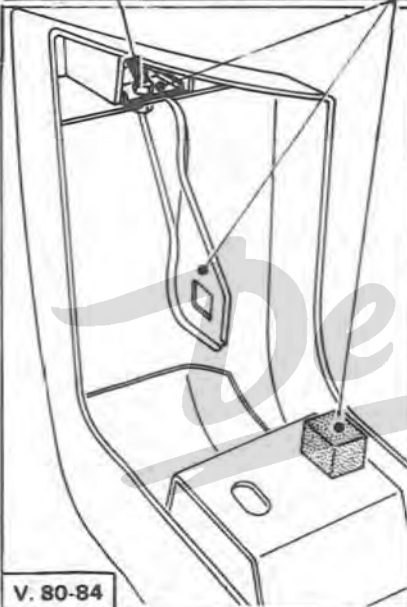
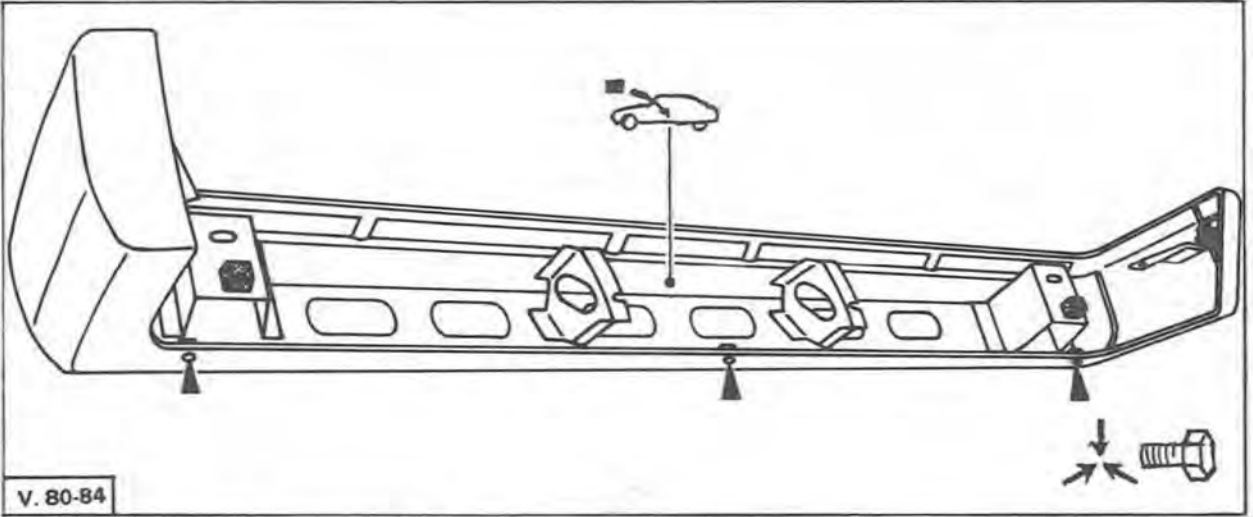
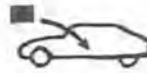
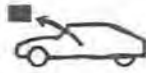

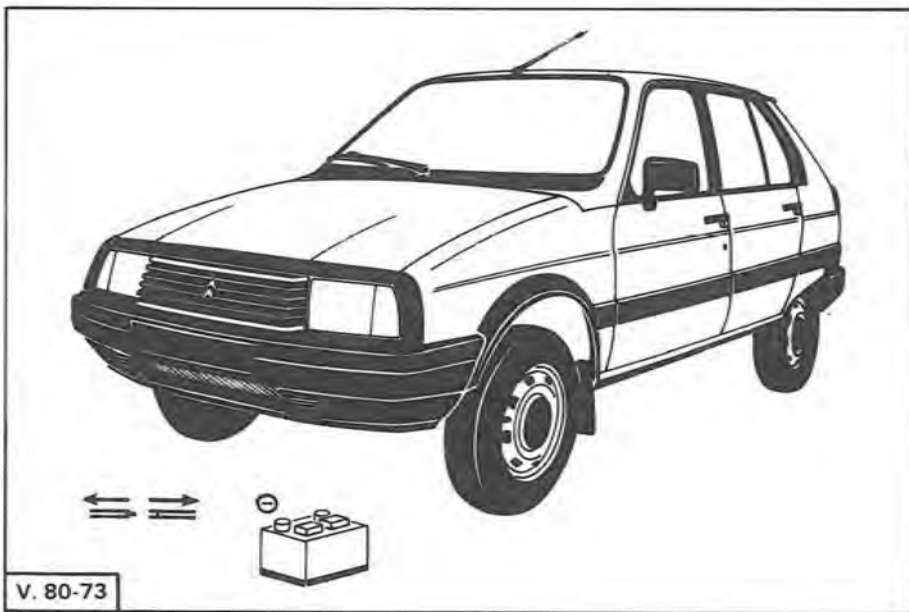
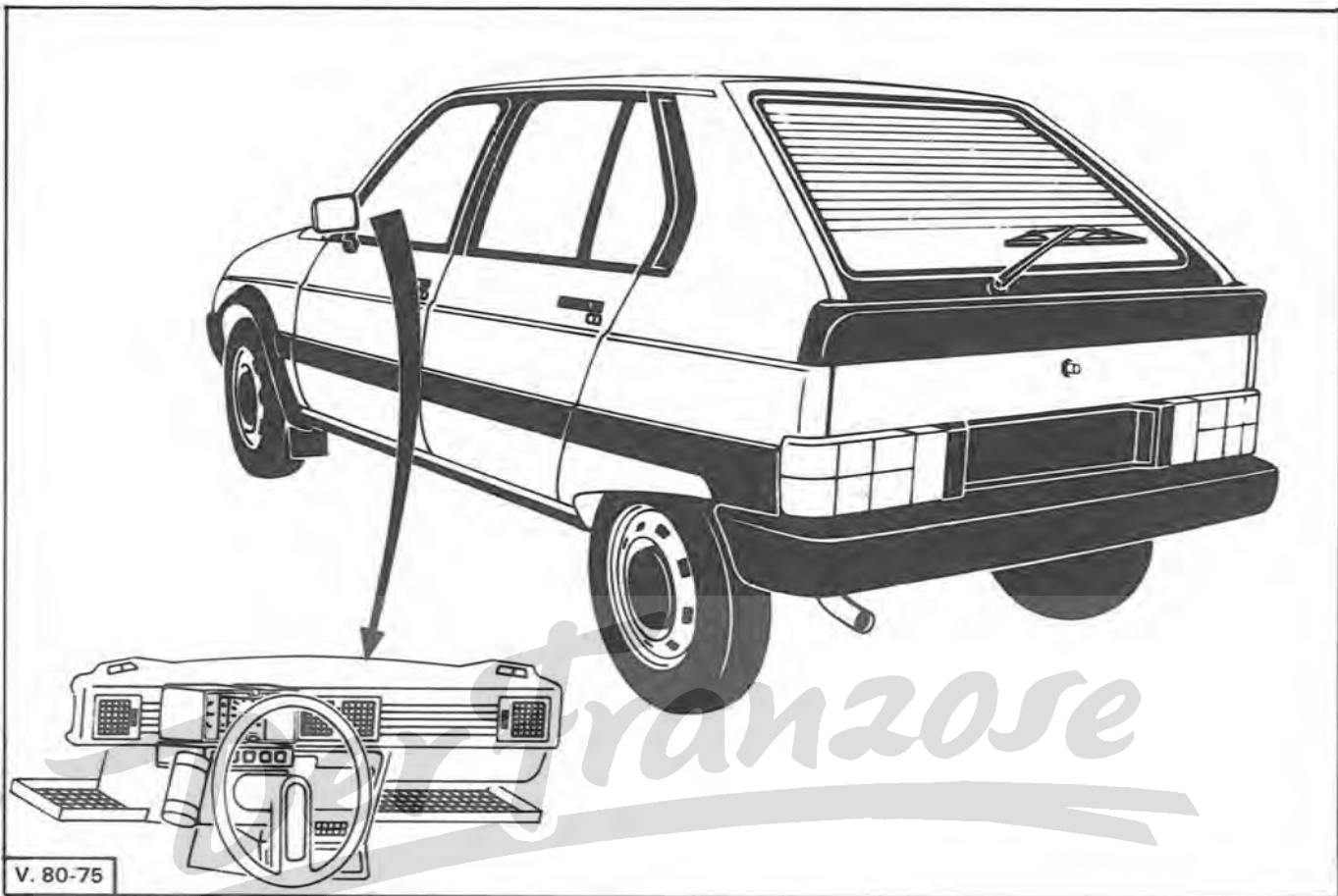
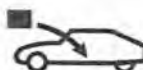
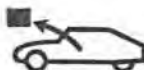

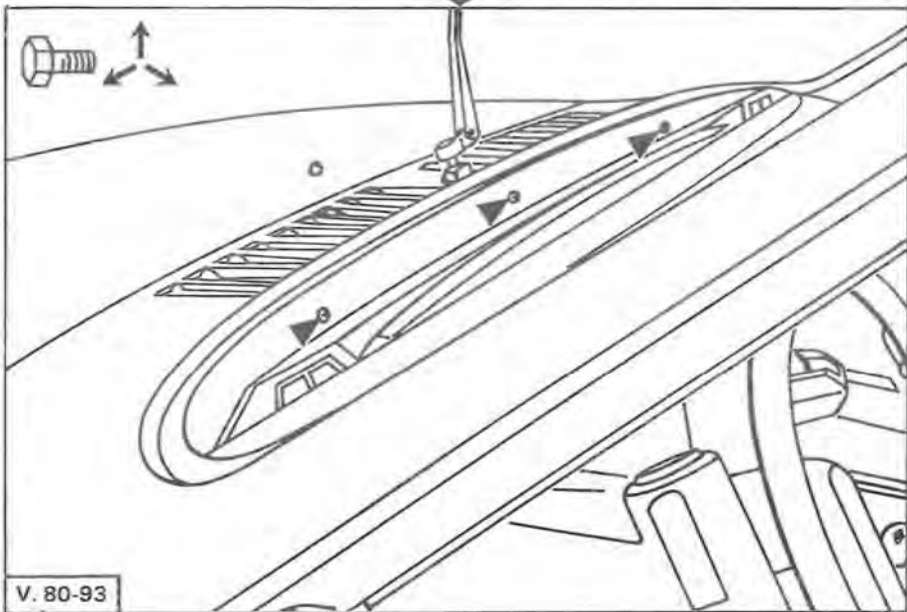
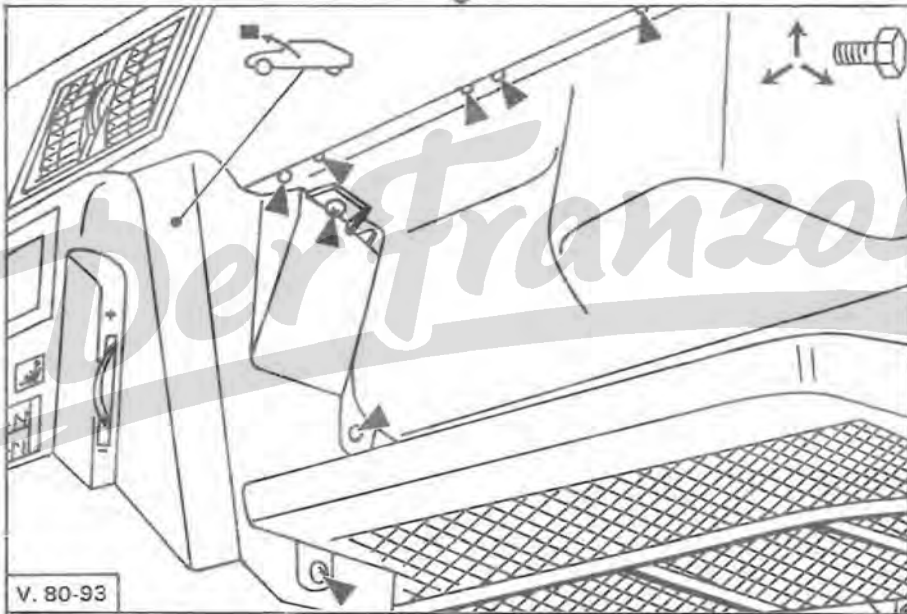
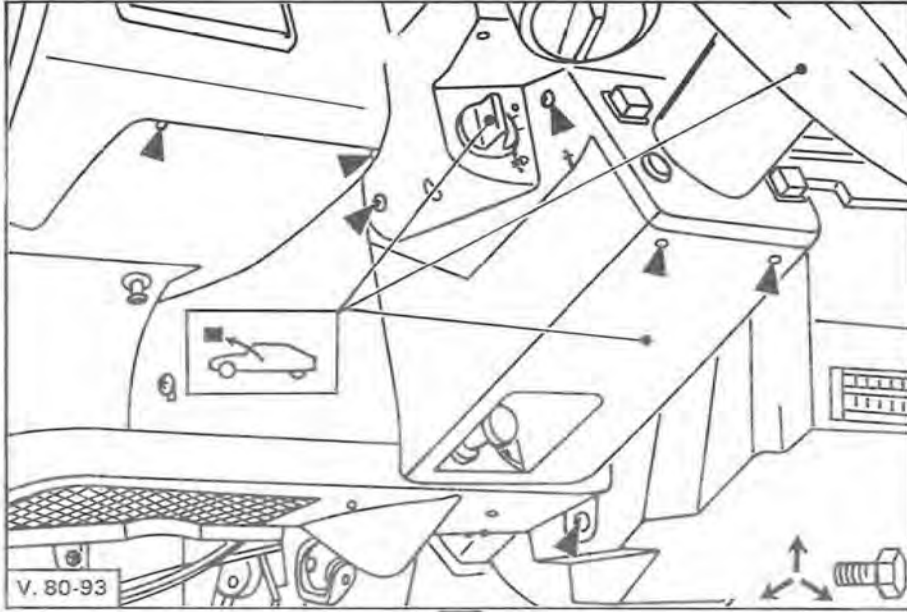
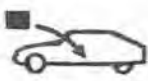
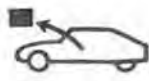

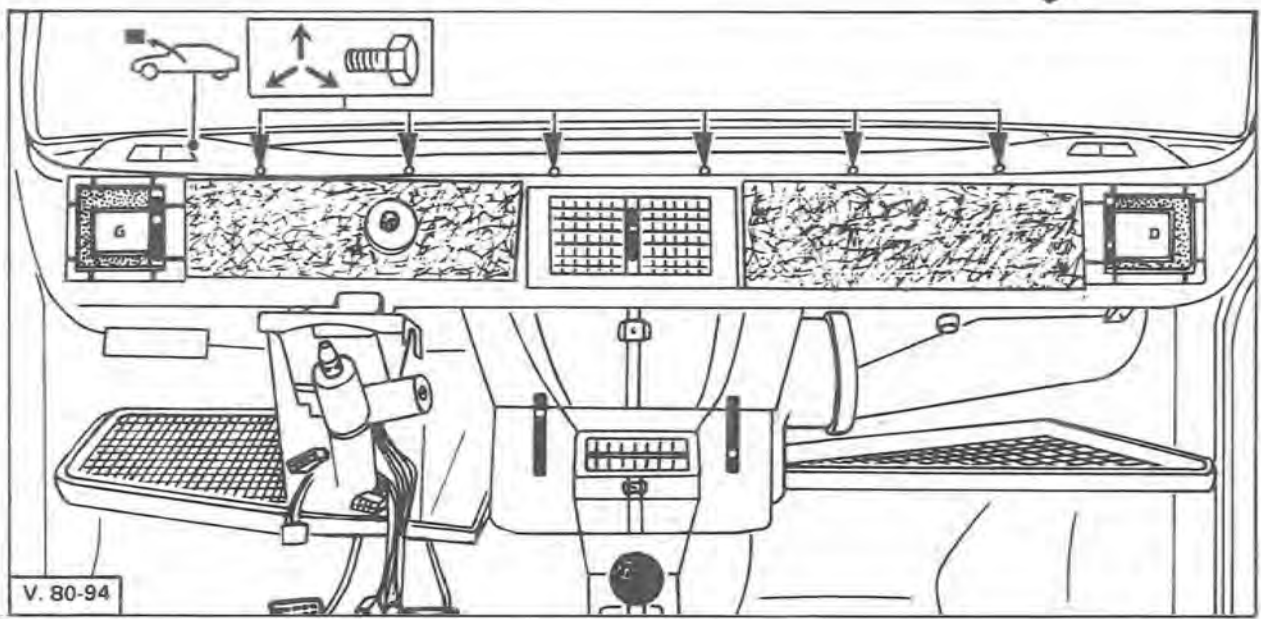
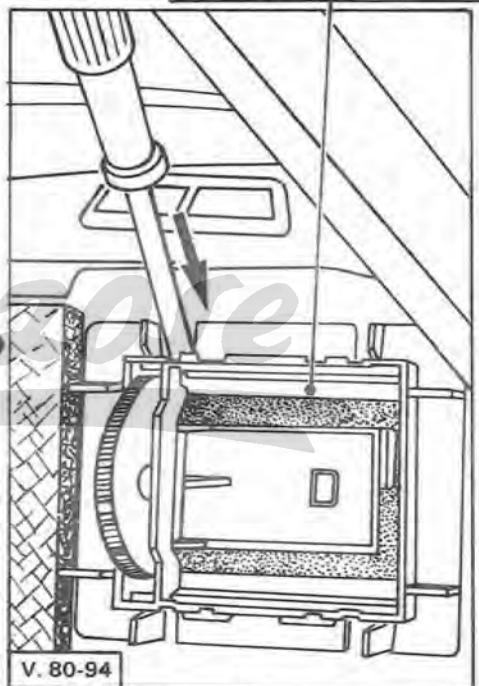
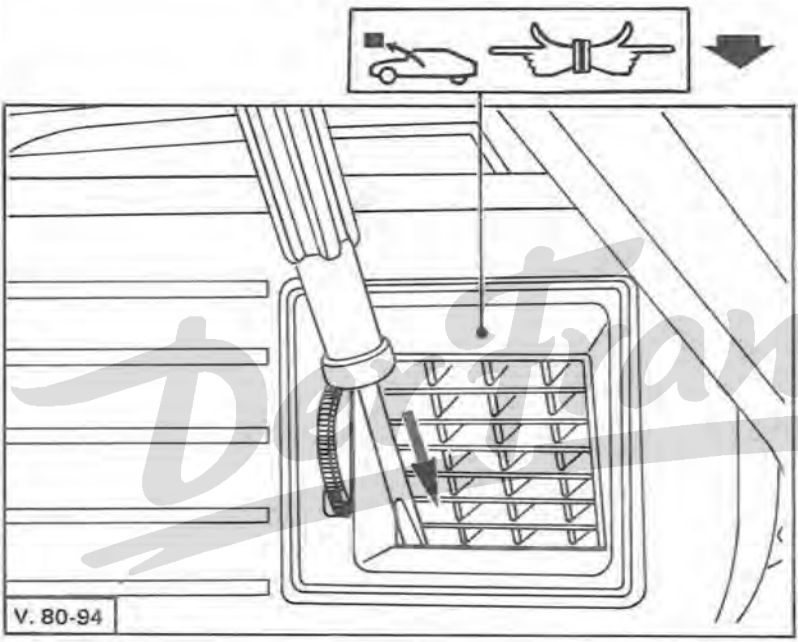
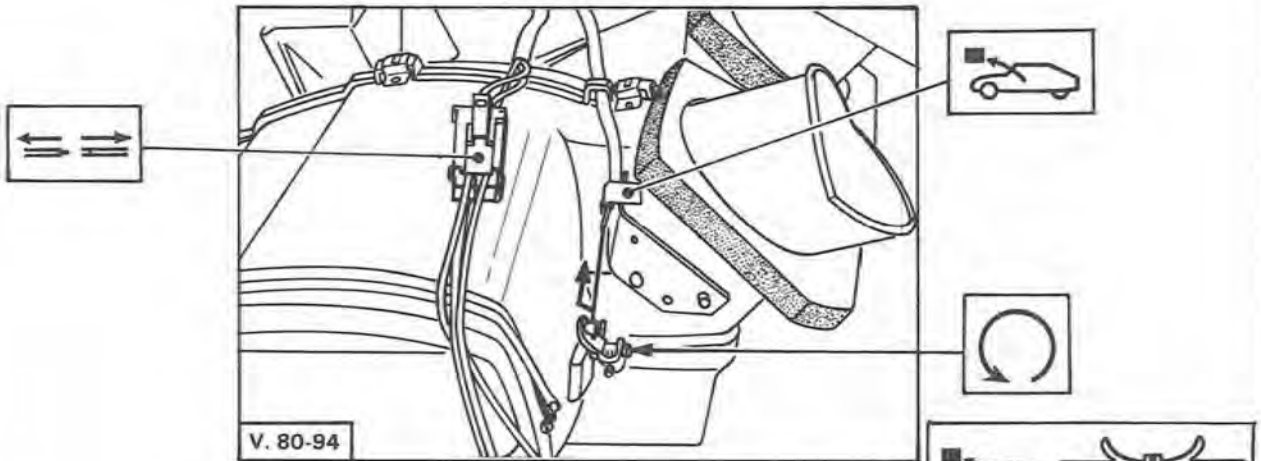

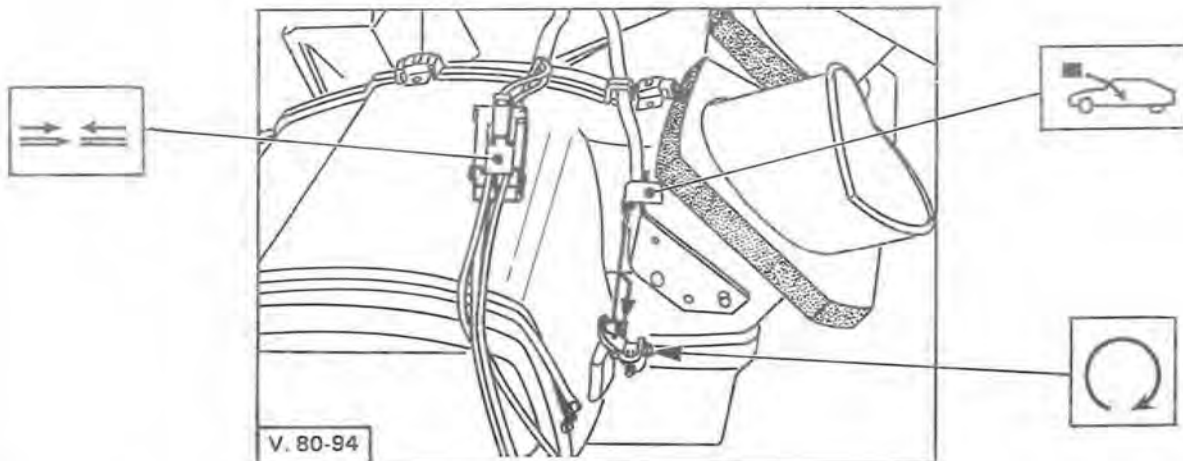
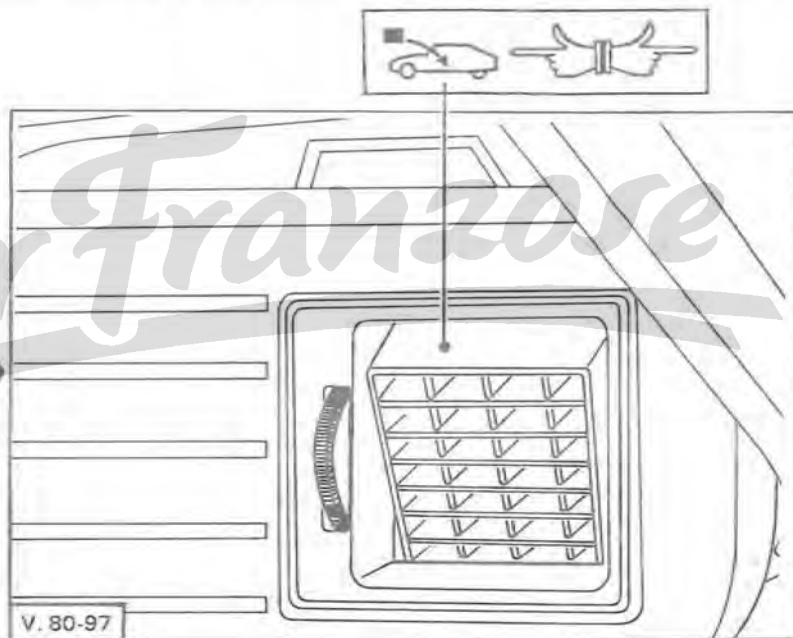
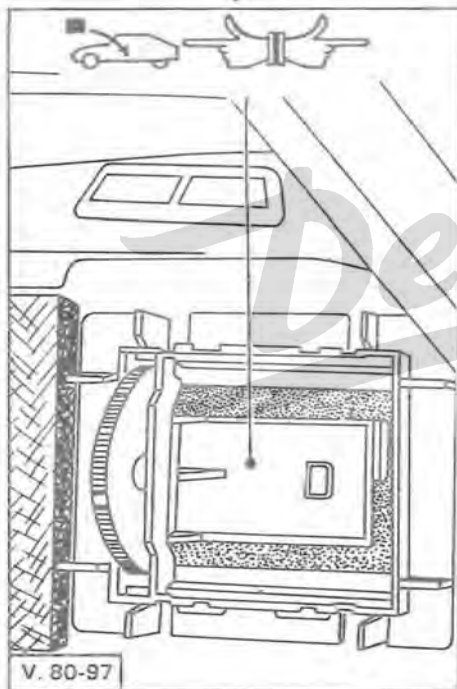
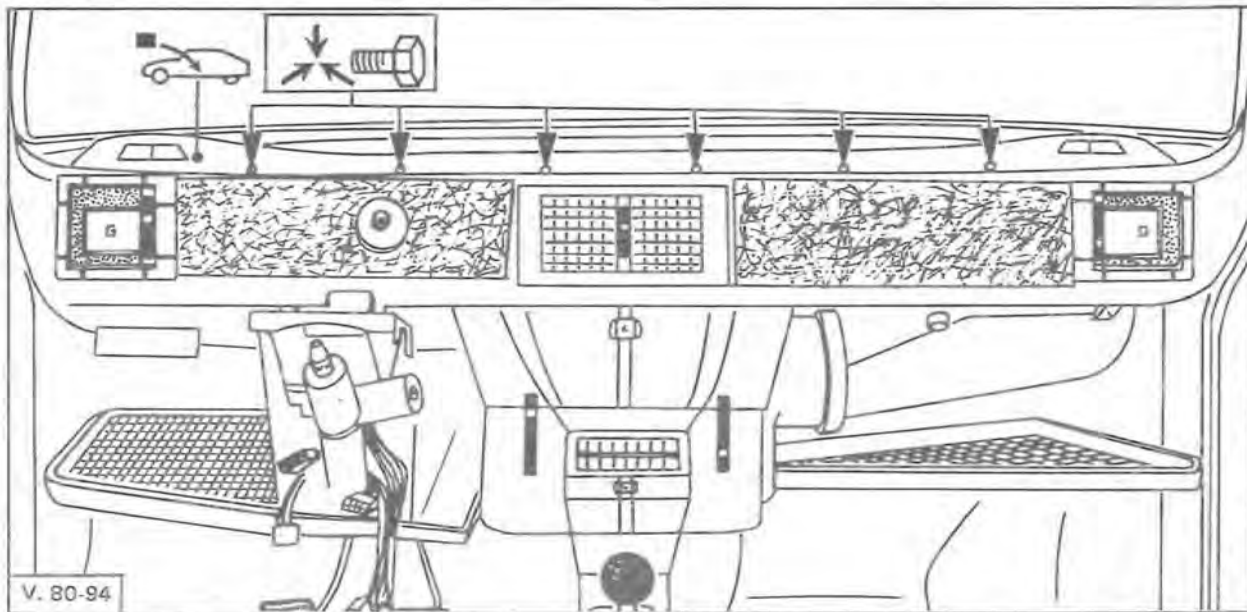
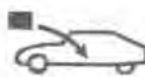

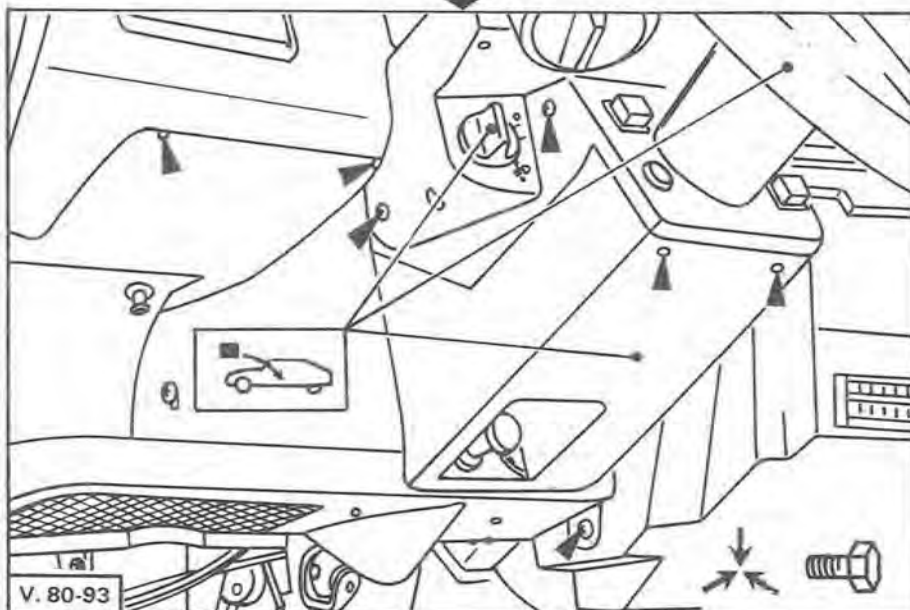
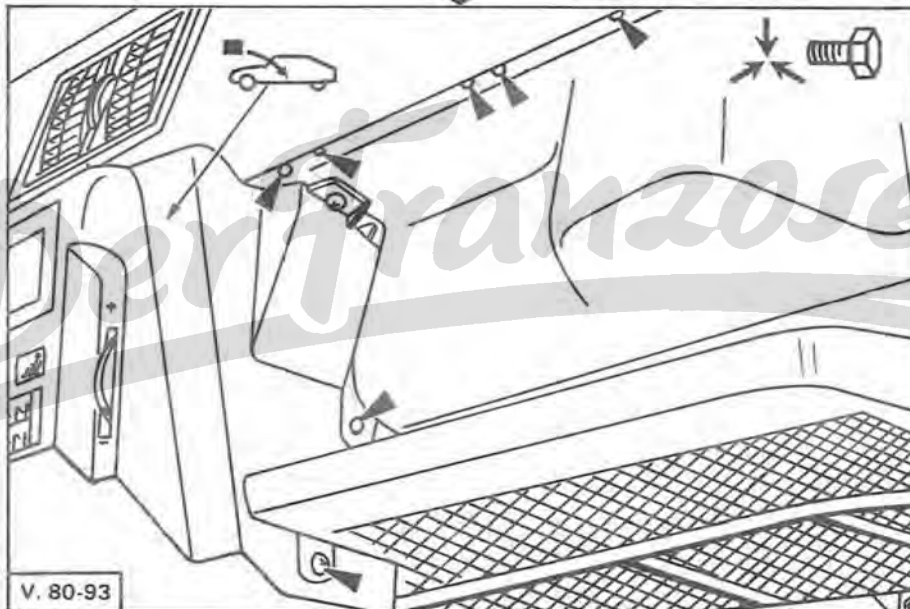
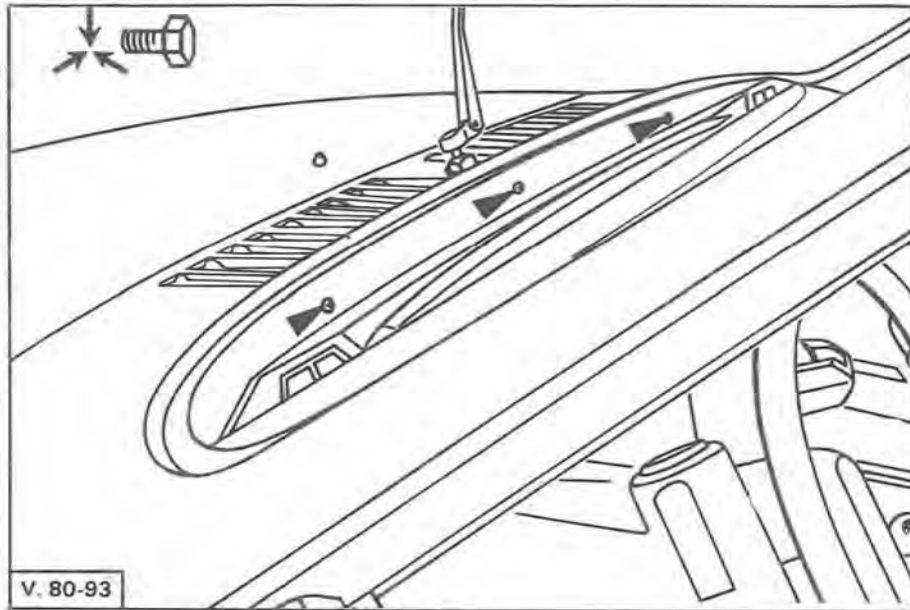
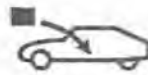

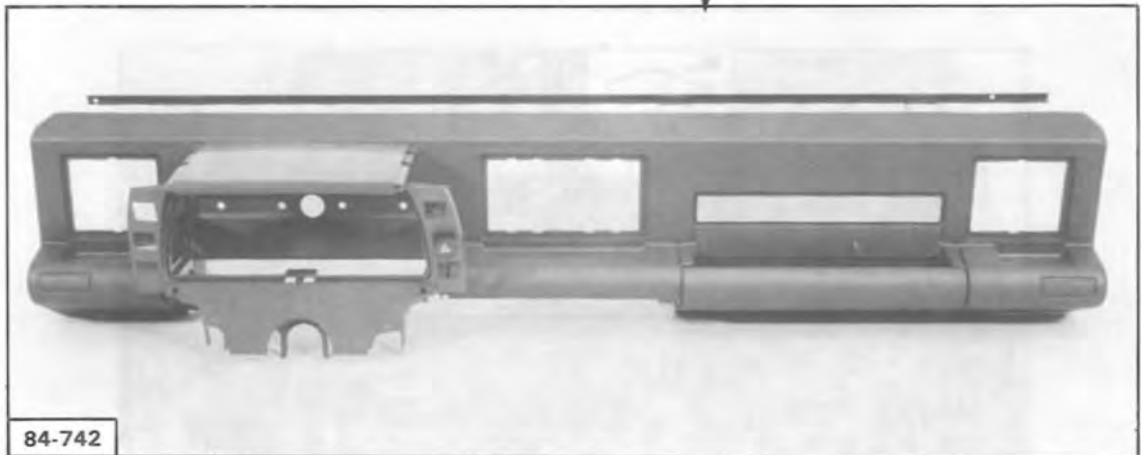

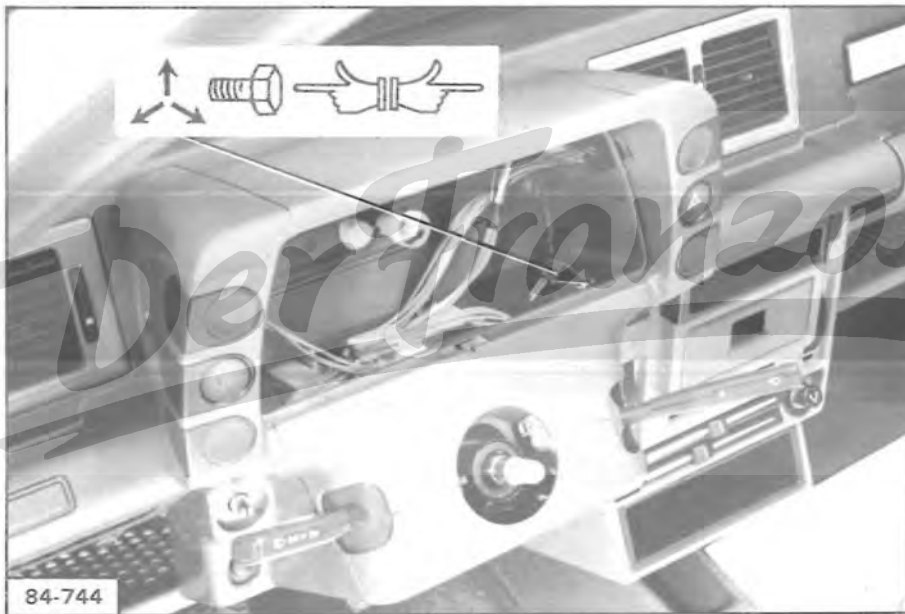
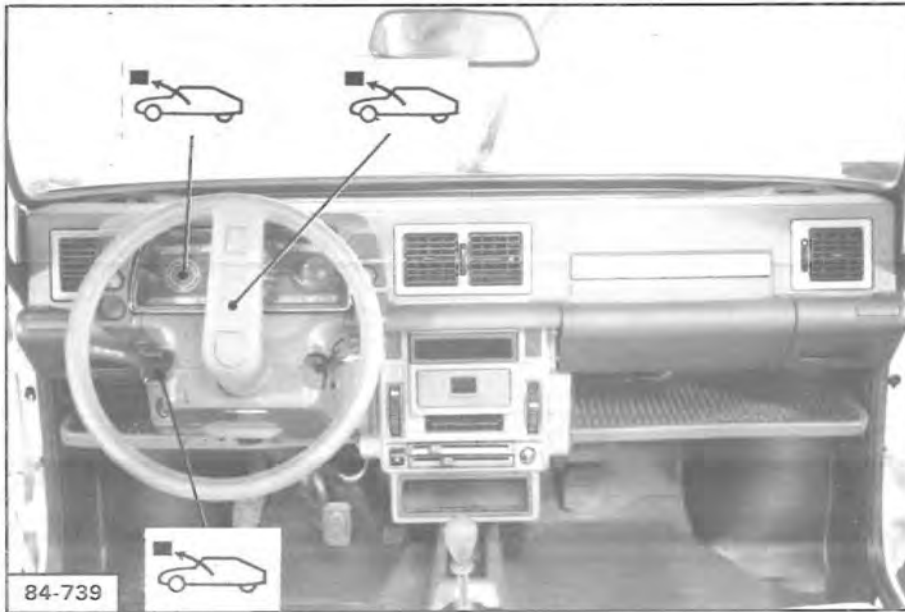
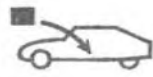
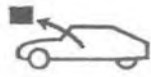

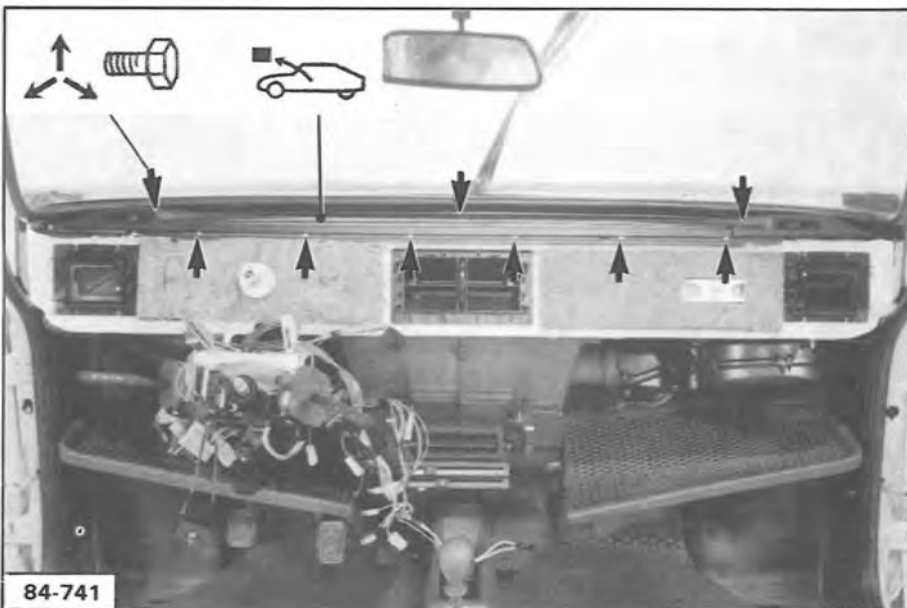
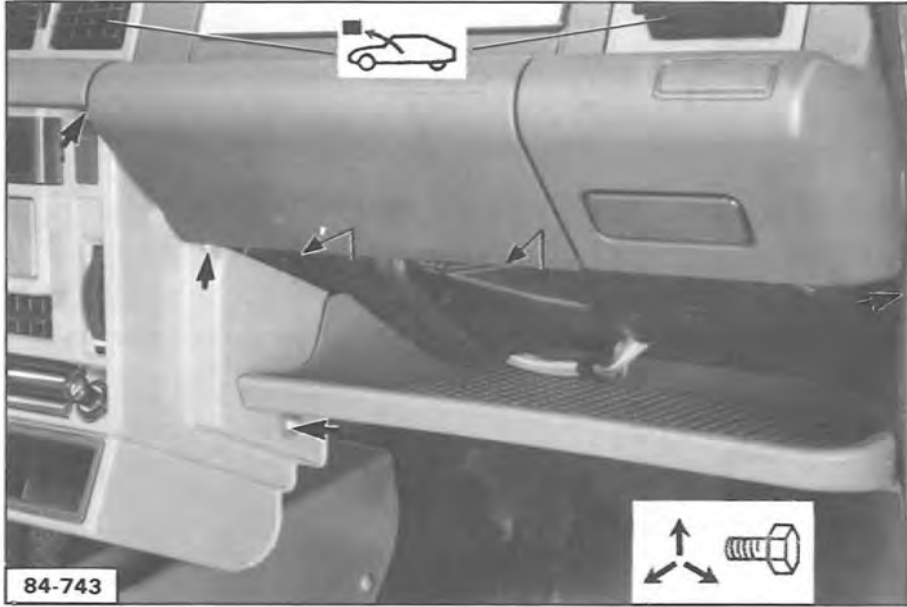
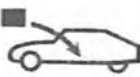

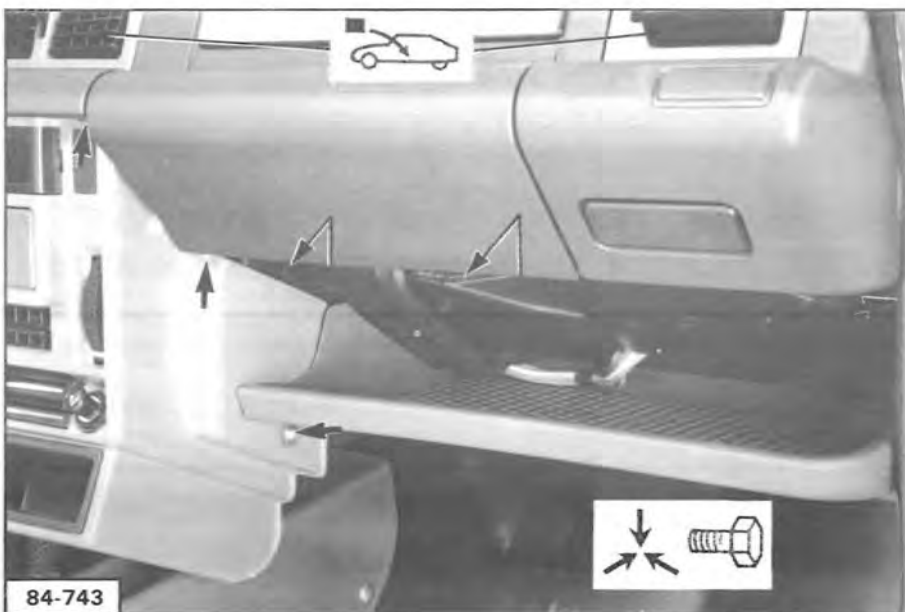
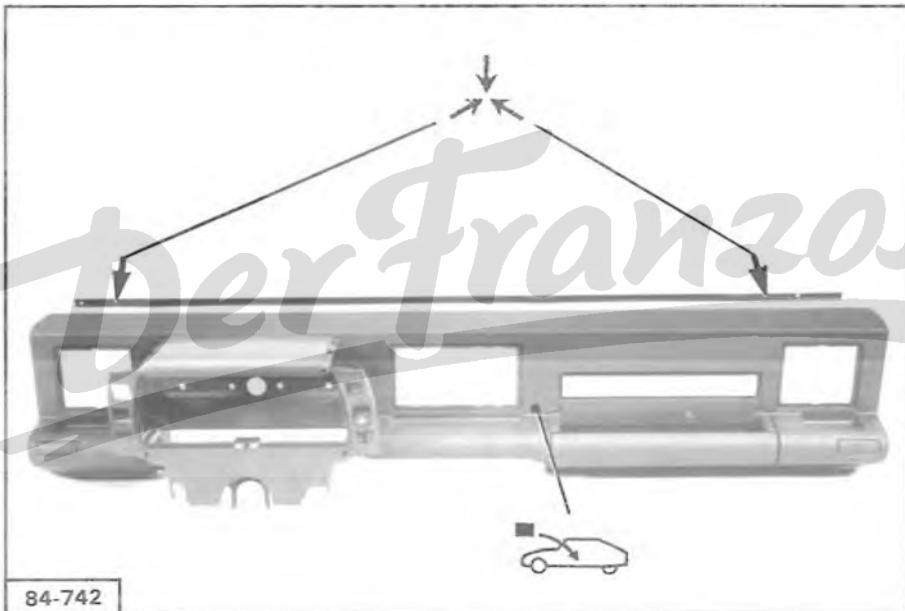
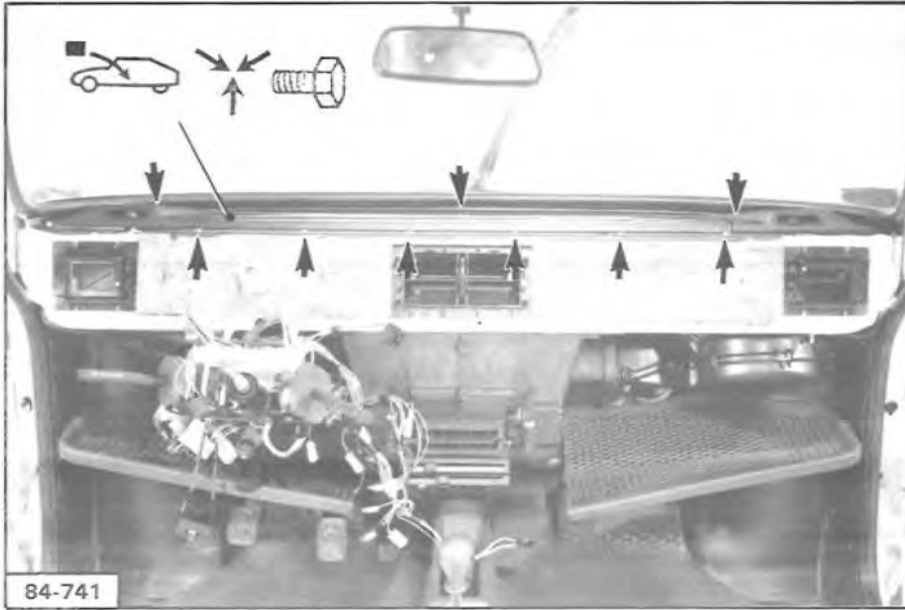

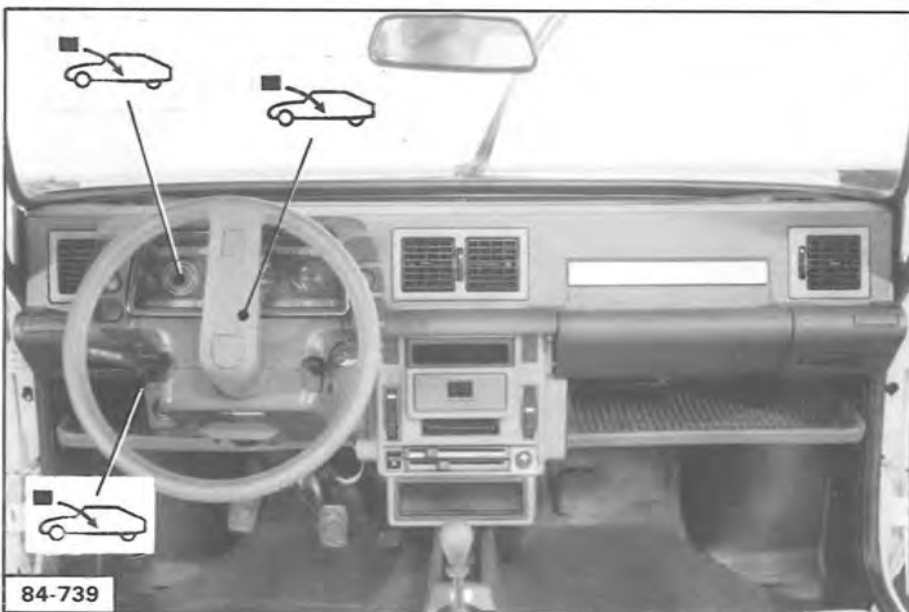
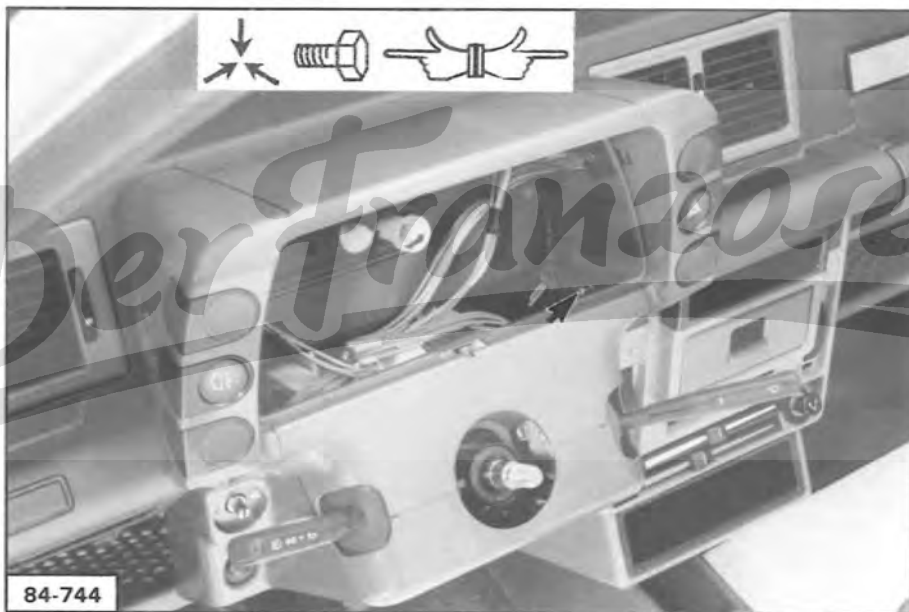

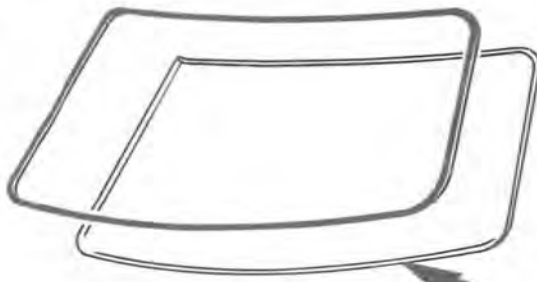
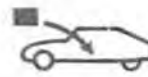
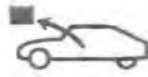

V. 80-73

Der Francose

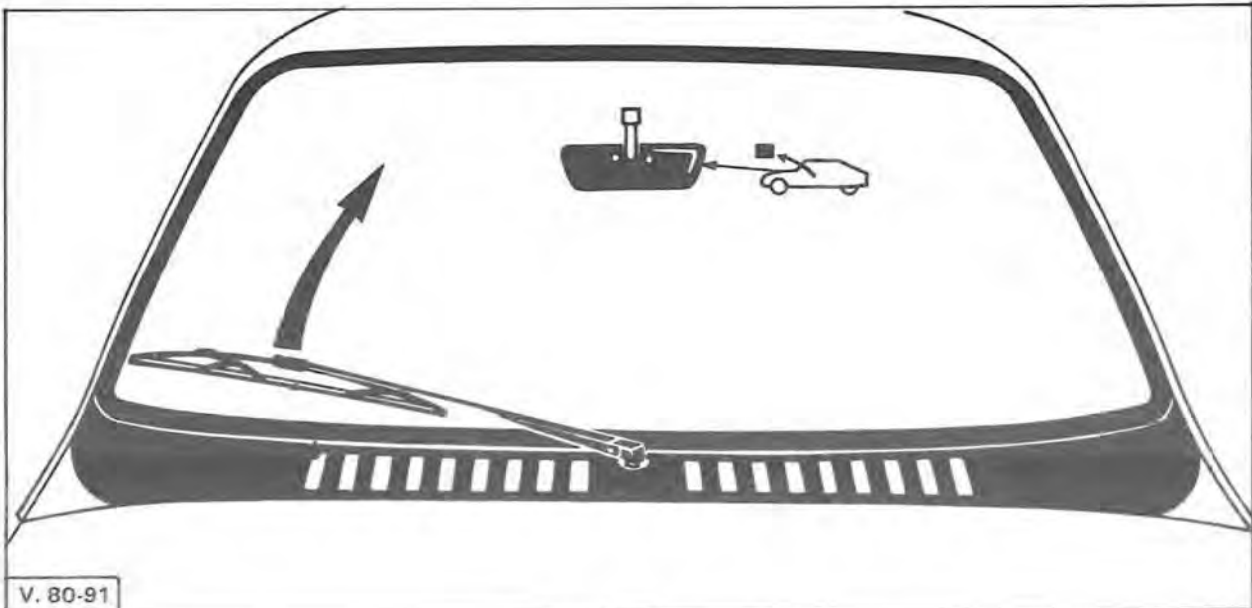
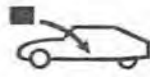
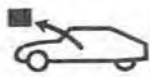

V. 80-91

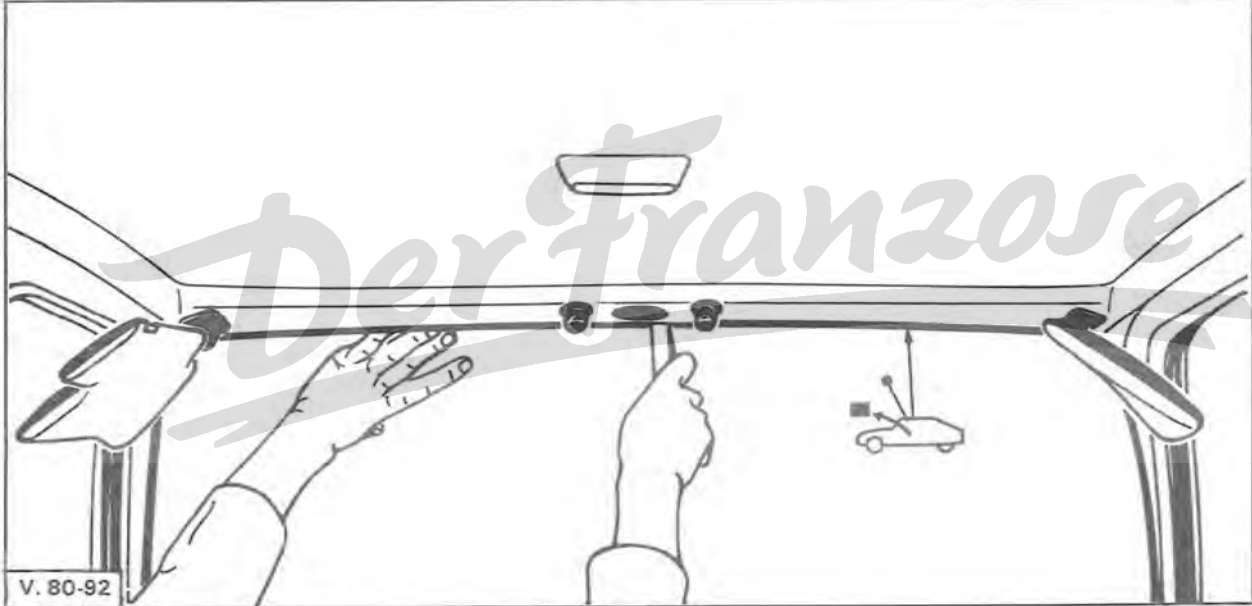

V. 80-92

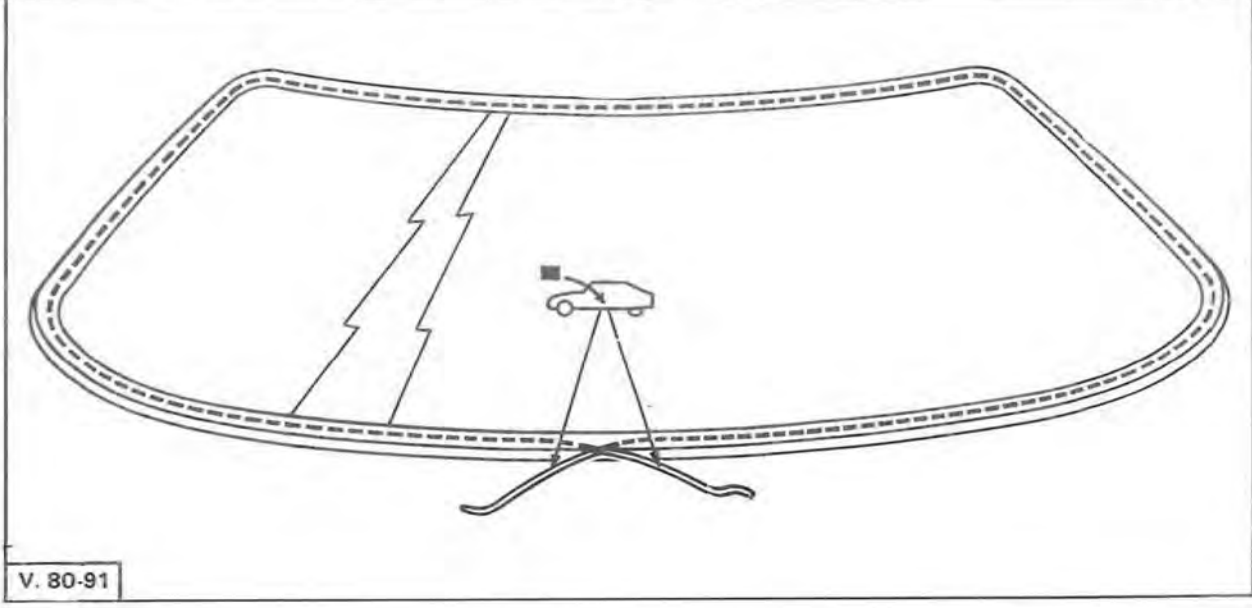

V. 80-91

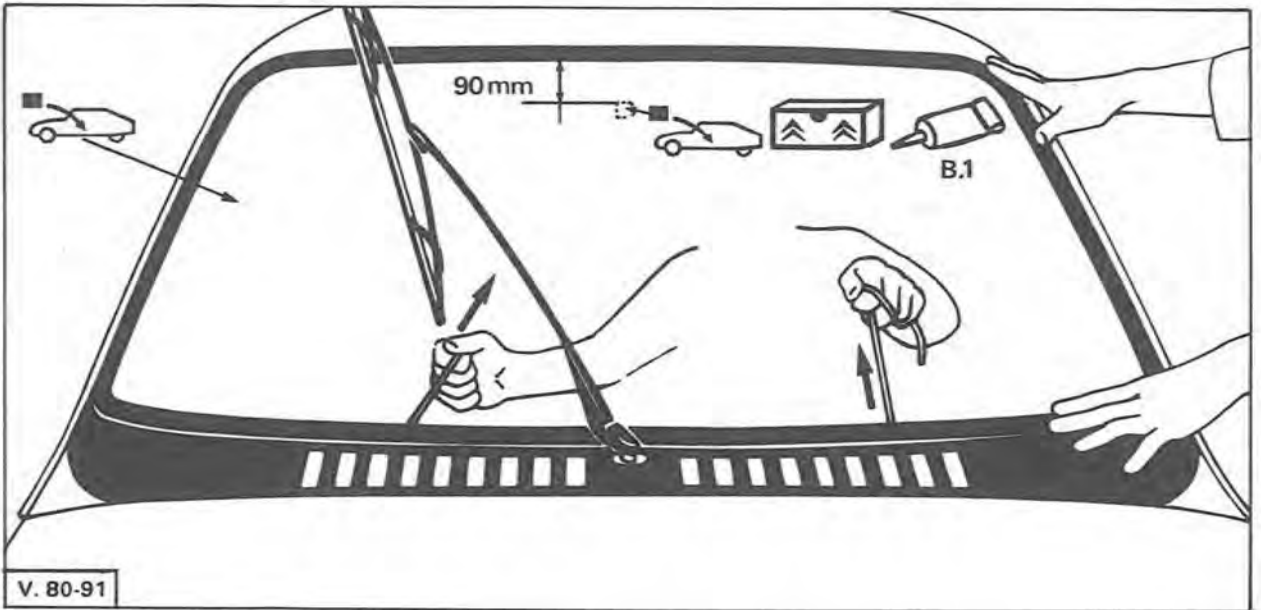

Der Franzose

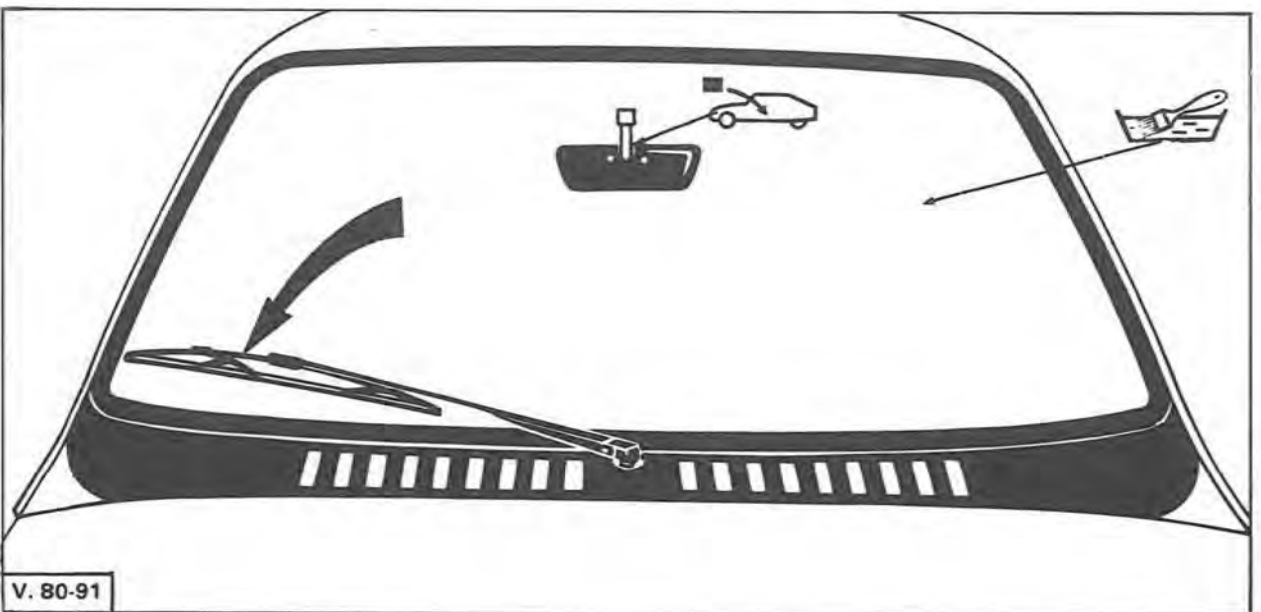

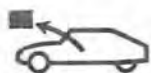

V. 80-75 a

Der Franzose

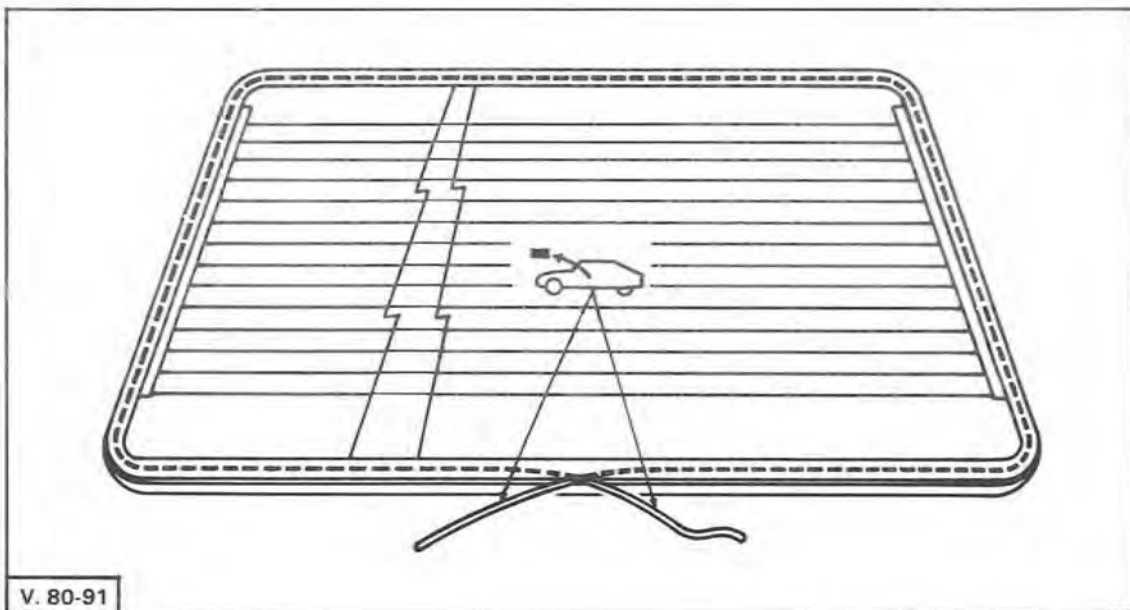
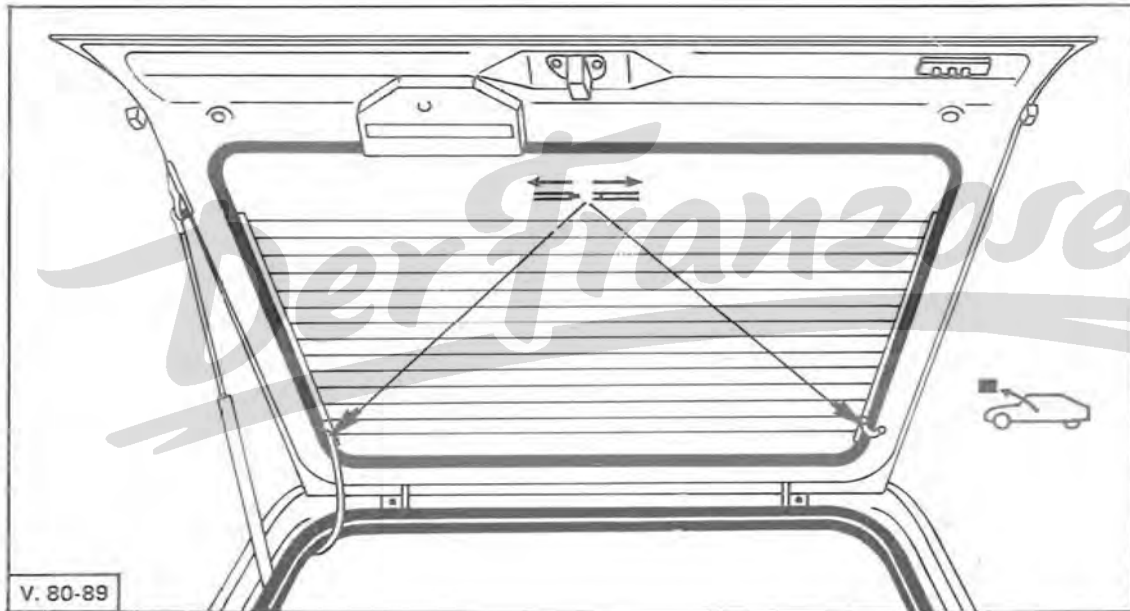
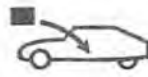

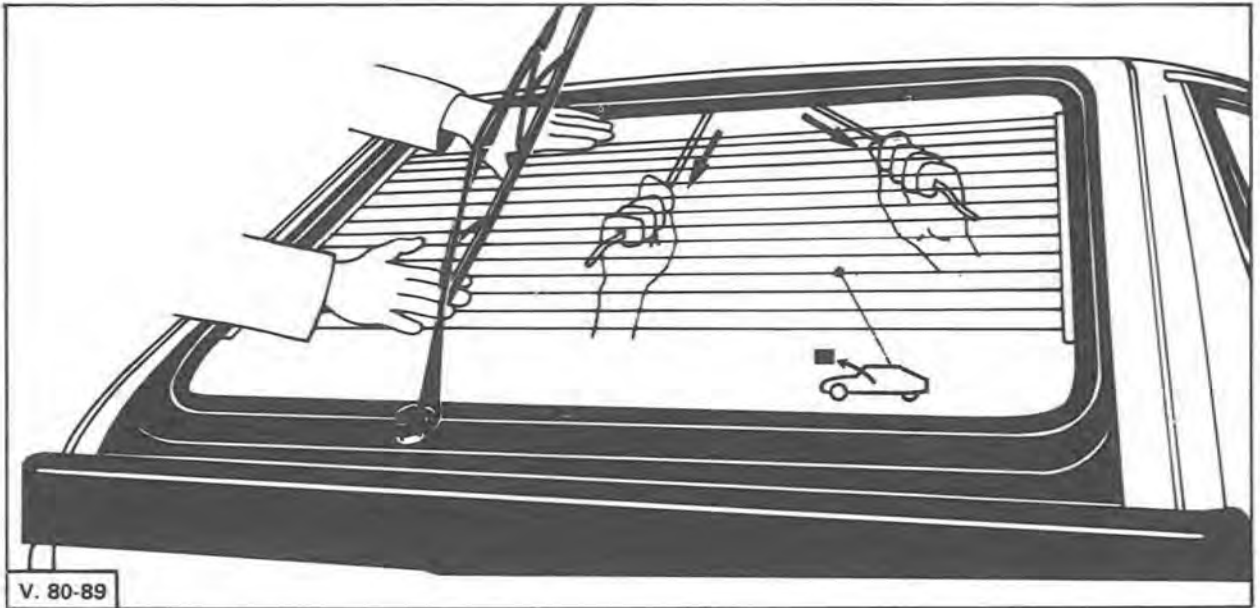
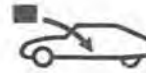
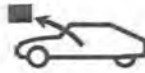

V. 80-89

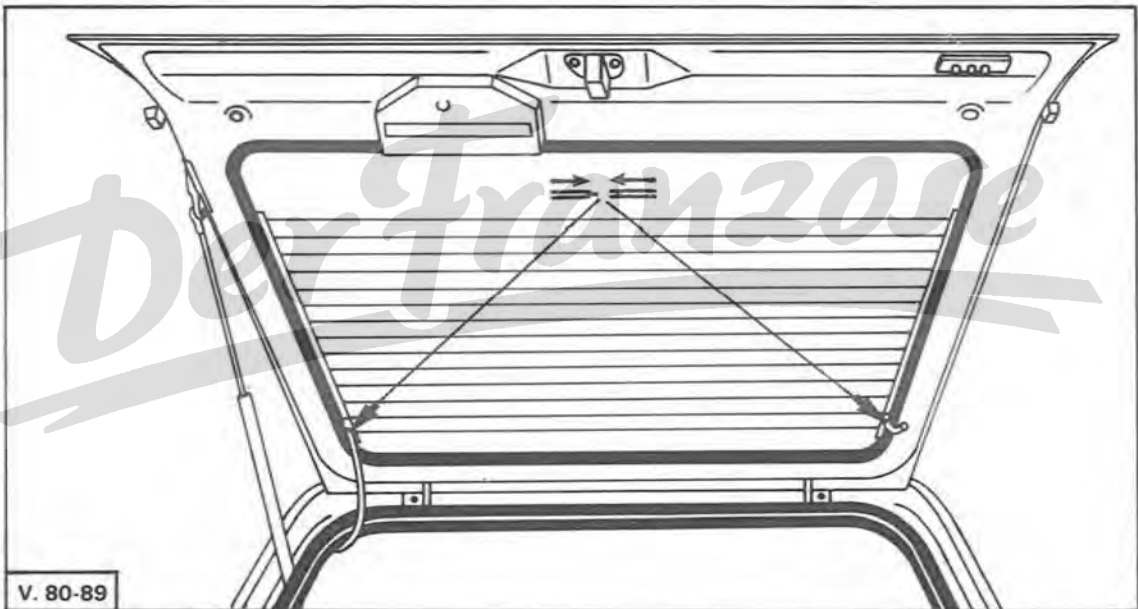

V. 80-89



V. 80-75

MR 630-84/44

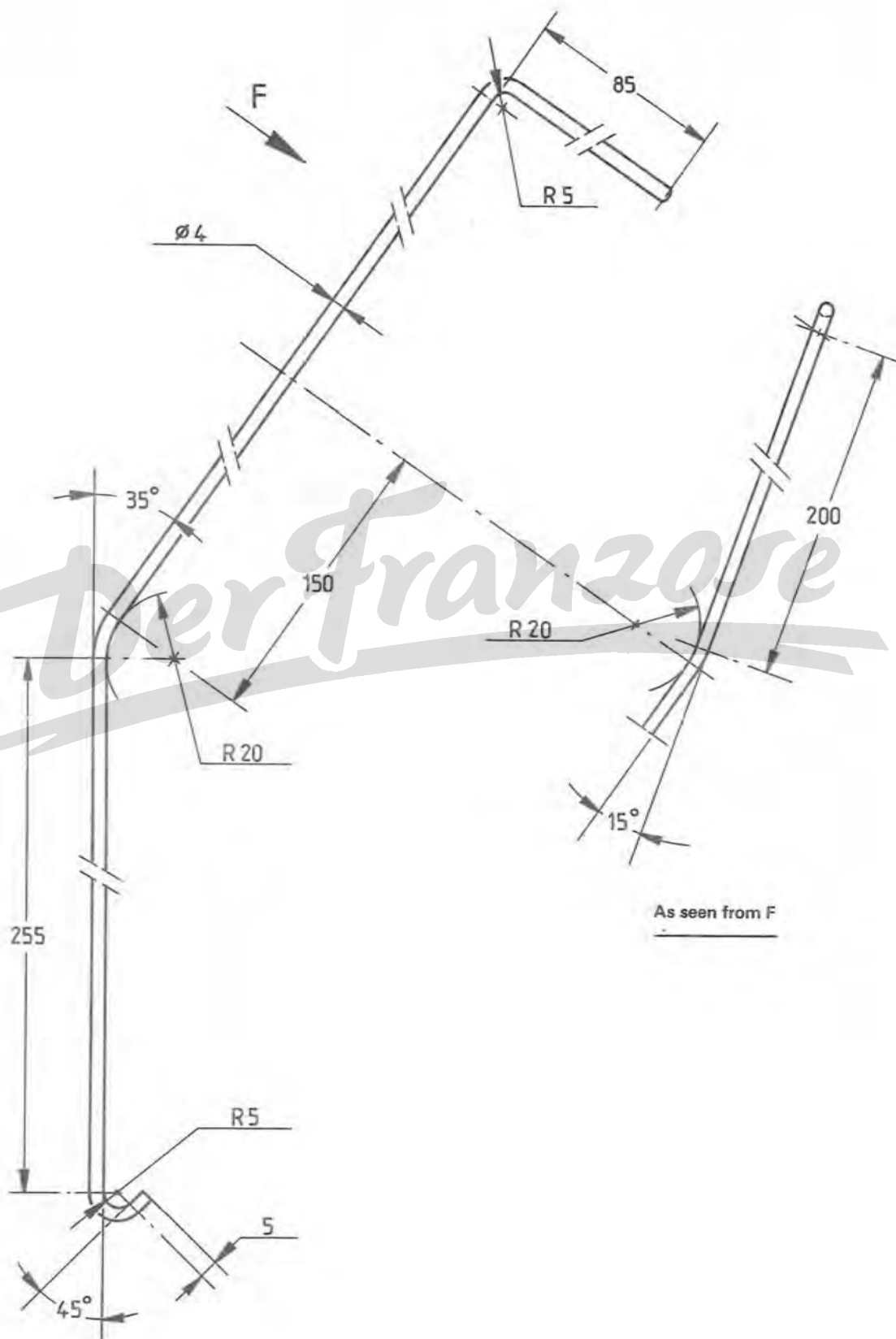

Der Franzose

PLAN ZUR HERSTELLUNG DES IN DIESEM KAPITEL
VERWENDETEN MR-WERKZEUG

Anzufertigendes Werkzeug

MR 630-84/44: Werkzeug zum Öffnen der Motorhaube (im Falle, wenn das Schloß nicht funktioniert)

Material: gezogener Stahl A 33-1- $\varnothing = 4$ mm.
Länge = 738 mm (ungefähr).

Der Franzose